



## Hybrid Wire to Wireless Fire Solutions

Engineering peace of mind

### Key features

- Bi-directional wireless communication
- Self optimising wireless amplitude and frequency
- Automatic wireless channel hopping
- Fully Intelligent
- High reliability and sensitivity
- Flexible on site device adjustment
- Makes additions to existing wired systems easy and cost effective
- Utilises standard low cost lithium battery technology
- Fully monitored primary and secondary power sources

### Reference: HFW-PA-01, HFW-TA-01 & HFW-MA-01

Hyfire Detection Range

The HFW range of Intelligent Detectors come in three variants; Optical, Thermal and Multi Criteria. All devices are compatible with the Hyfire loop Translator Modules and Expander Modules.



#### Additional Information

- The detectors parameters are programmed via the Translator Module either by a wireless keypad or a PC link.
- The Translator Module automatically manages detector radiation power depending on the device communication quality.
- Detectors automatically adjusts its frequency and radiation in accordance with the signal quality received from the Translator Module.

#### Design

- The patented smoke chamber ensures optimal smoke sensitivity from all directions. Whilst the double dust trap provides the chamber with increased protection from airborne contamination and background illumination (HFW-PA-01 & HFW-MA-01 models)
- Each detector is fitted with a reed switch facility allowing testing and programming using a magnet

#### Algorithm

- Adaptive signal processing helps with the elimination of false alarms
- Temperature compensation gives reliable and steady operation in low and high temperatures and compensates for differences in temperature between the Translator and field device locations.



Unit B12a  
Holly Farm Business Park  
Honiley, Warwickshire CV8 1NP  
T: 01926 485282  
F: 01926 485090  
E: info@sterlingsafety.co.uk



**HFW-PA-01**  
**HFW-TA-01**  
**HFW-MA-01**

Detector Range

**Power Supply**

Dual 3 V Lithium batteries:

1 x Primary CR 123 A  
 (1.2Ahr)

1 x Secondary CR2032A  
 (0.24Ahr)

The Hyfire Translator Module monitors the condition of both batteries and shows a discharge of either using an internal LED indicator as well as a fault indication at the Translator Module and Fire Detection Control Equipment.

**Indication**

- A bi-colour (red and green) LED indicator provides 360 degree cone of vision displaying information regarding the operational modes and condition of power supplies.

-The indicator also provides information during the programming of the device regarding the wireless signal strength allowing defining of stable operating locations when installing the unit.

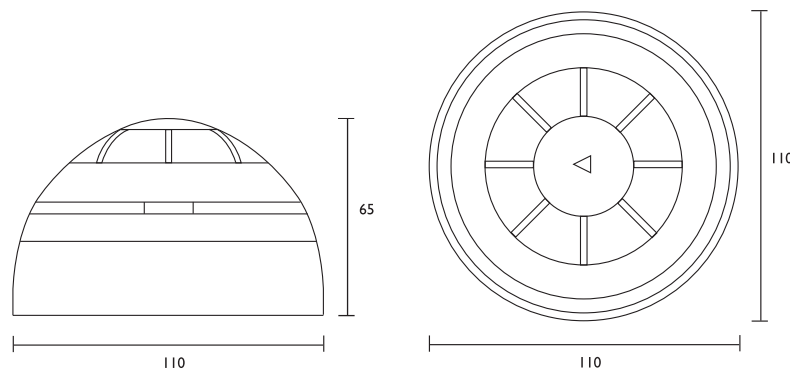

LED Indication	
Indication of device in standard mode following battery installation	Green LED Fast Blinking
Installation of device in programming mode following battery switch on	Red LED 4 Short Flashes
Device in Self Adjustment Mode	Red LED on with Occasional Blink

Technical Specification	
Communication Range with the Translator Module	150M (open space)
Operating frequency	868-870 MHz
Modulation Type	Frequency Modulation
Number of Operating Channels	7
Time period between wireless signal transmissions	From 12 sec. to 2 min.
Estimated battery life (Dependant on time period between wireless signal transmissions)	
Primary Cell (CR123A)	Between 3 and 5 years
Secondary Cell (CR2032A)	2 months
Dimensions	110mm x 65mm
Operating Temperature Range	-30 C to +50 C
Radiated Power	0.01 - 10mW