

Key features

- Bi-directional wireless communication
- Self optimising wireless amplitude and frequency
- Automatic wireless channel hopping
- Fully intelligent
- High reliability and sensitivity
- Flexible on site device adjustment
- Makes additions to existing wired systems easy and cost effective
- Utilises standard low cost lithium battery technology
- Fully monitored primary and secondary power sources
- Weatherproof and colour variants available

Reference: HFW-WSR-01, HFW-WSW-01, HFW-SBR-01 & HFW-SBW-01

Wireless Audio and Visual Warning devices

The HFW warning devices are a comprehensive range of fully intelligent wireless alarm signalling units, providing a signalling solution for a wide variety of system sizes and types.



Additional Information

- Sounder and Sounder / Beacon parameters are programmed via the Translator Module either by a wireless keypad, PC Link or its on board keyboard.
- The Translator Module automatically manages detector radiation power depending on the device communication quality.
- All Audio Visual warning devices automatically adjust their frequency and radiation in accordance with the signal quality received from the Translator Module.

Design

- The Sounder comes as standard with three tones.
- The unit is fitted with a volume control and is adjustable up to a maximum output of 100 dB(A).
- All devices are fully controllable from the control panel via the Translator Module and offers the same level of flexibility as a standard addressable loop sounder.
- Temperature compensation gives reliable and steady operation in low and high temperatures and compensates for differences in temperature between the Translator and field device locations.



Unit B12a
Holly Farm Business Park
Honiley, Warwickshire CV8 1NP
T: 01926 485282
F: 01926 485550
E: info@sterlingsafety.co.uk

HFV-WSR-01

Wireless Wall Sounder

Power Supply

Dual 3 V Lithium batteries:
2 x Primary CR123A
(1.2Ahr)

The primary and secondary cells alternate in providing power to the sounder. The Hyfire Translator Module monitors the condition of both batteries and shows a discharge of either using an internal LED indicator as well as a fault indication at the Translator Module and Fire Detection Control Equipment.

Indication

- A bi-colour (red and green) internal LED indicator provides information regarding the operational modes and condition of power supplies.

- The indicator also provides information during the programming of the device regarding the wireless signal strength allowing defining of stable operating locations when installing the unit.

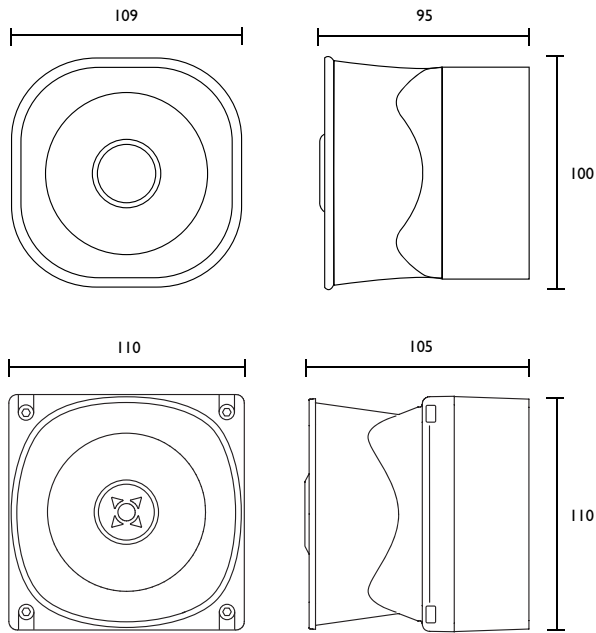

Technical Specification

Communication range with the Translator Module	150M (open space)
Operating Frequency	868-870 MHz
Modulation Type	Frequency Modulation
Number of Operating Channels	7
Time Period Between Wireless Signal Transmissions	From 7 sec. to 1 min.
Estimated Battery Life (Dependant on time period between wireless signal transmissions)	
Primary Cell (CR123A)	3 years
Secondary Cell (CR123A)	2 Months
Dimensions	109mm x 96mm
Operating Temperature Range	-30°C to +50°C
Radiated Power	0.01 - 10mW
Sound Output	100dBA
Flash Rate (Beacon only)	1Hz
Light Output (Beacon only)	1Cd