

# Planning Instructions

MEW00227

Revision 2

## ***Fire Alarm System EBL512 V2.1.x***

Author:	Jan Pettersson	Date of issue: 2002-02-25	Date of rev: 2002-12-16
---------	----------------	---------------------------	-------------------------

This page has deliberately been left blank.

# Table of contents

---

<b>1</b>	<b>Introduction</b>	<b>7</b>
1.1	Main differences between EBL512 version 2.0.x and 2.1.x	8
1.1.1	Convention setting	8
1.1.2	Addressable short circuit isolator 2370	8
1.1.3	DBI (Danish) convention	8
1.1.4	British Standard Marine Application convention	8
1.2	Main differences between EBL512 version 2.1 and 2.1.1	8
1.2.1	DBI (Danish) convention	8
1.3	Main differences between EBL512 version 2.1.1 and 2.1.3	8
<b>2</b>	<b>Definitions / Explanations</b>	<b>10</b>
2.1	MFSTech	10
2.2	Alarm points	10
2.2.1	Smoke detector	10
2.2.2	Sensor	10
2.2.3	Analog detector	10
2.2.4	Analog (Sensor) Base (ASB)	10
2.2.5	Conventional detector	10
2.2.6	(Conventional Detector) Base (CDB)	10
2.2.7	Addressable (Detector) Base (ADB)	10
2.2.8	Addressable	11
2.2.9	Old detector	11
2.2.10	External line / Conventional zone line	11
2.2.11	ADB input / Addressable zone interface	11
2.3	Output unit	11
2.4	Output / Control output	11
2.5	Short circuit isolator	11
2.6	Display unit	11
2.7	COM loop	11
2.8	BS4 loop	11
2.9	Control Unit (C.U.) / C.I.E.	12
2.10	Fire Brigade Panel (FBP)	12
2.11	Control panel (CP)	12
2.12	System	12
2.13	Network / TLON <sup>®</sup> / LonWorks <sup>®</sup> / Echelon / Node / TLON Conn. board / Gateway / Sub net / Backbone net / Router / Repeater	12
2.14	LED	13
2.15	External Indicator (LED)	13
2.16	Display / LCD	13
2.17	Door open / Key switch	13
2.18	SSD / Site Specific Data	13
2.19	SW / Software / System program	13
<b>3</b>	<b>Overview</b>	<b>14</b>

---

3.1	The EBL512 system	14
3.1.1	Expansion boards	14
3.1.2	Printer	14
3.2	SW Versions	14
3.3	Backwards compatibility	15
3.3.1	Upgrade the Site Specific Data (SSD)	15
3.3.2	Upgrade the EBL512 control unit (c.i.e.)	15
3.4	Documents	17
3.5	Applications	17
3.6	PC SW	17
3.6.1	Win512	17
3.6.2	TLON Manager	17
3.6.3	NEWTEXT	17
<b>4</b>	<b>Control Unit / TLON Network</b>	<b>18</b>
<b>5</b>	<b>Control Units 1548 - 1550</b>	<b>19</b>
5.1	COM loops	21
5.2	Programmable voltage outputs (S0-S3)	22
5.3	Programmable relay outputs (R0-R1)	22
5.4	Programmable inputs (I0-I3)	23
5.5	Relay outputs for routing equipment (tx)	23
5.5.1	Fire alarm output	23
5.5.2	Fault output	23
<b>6</b>	<b>Expansion boards 1580 – 1584</b>	<b>25</b>
6.1	Expansion board address setting	25
6.2	8 zones expansion board 1580	26
6.3	8 relays expansion board 1581	26
6.4	External Fire Brigade Panel (FBP) interface board 1582	27
6.5	German FBP interface board 1583	27
6.6	Autronica interface board 1584	28
<b>7</b>	<b>Printer board 1558</b>	<b>30</b>
<b>8</b>	<b>TLON connection board 1590</b>	<b>31</b>
<b>9</b>	<b>Peripheral devices</b>	<b>32</b>
9.1	COM loop units	32
9.1.1	Input units	34
9.1.2	Output units (addressable)	44
9.1.3	I / O units (addressable)	45
9.1.4	Alarm devices (addressable sounders)	45
9.1.5	Display units (addressable)	46
9.1.6	Short circuit isolator (addressable)	49
9.2	BS4 loop units	51
9.3	Units for Hazardous (Ex) areas	51
9.3.1	Addressable IS zone interface (AIS)	51
9.3.2	Galvanic isolator	52
9.3.3	Intrinsically Safe mounting base	52

---

9.3.4	Intrinsically Safe photoelectric smoke detector	52
9.3.5	Intrinsically Safe heat detector	52
9.3.6	Intrinsically Safe manual call point	52
9.4	Other units	52
<b>10</b>	<b>Programmable inputs</b>	<b>57</b>
10.1	Control unit Inputs I0 - I3	57
10.2	The 2276 unit's Input0 - Input7	58
10.3	The 3361 unit's Inputs In0 / Z & In1	58
<b>11</b>	<b>Input programming</b>	<b>59</b>
11.1	Trigger conditions	59
11.2	Logic	61
<b>12</b>	<b>Programmable outputs</b>	<b>62</b>
12.1	Control unit outputs S0 – S3	63
12.2	Control unit outputs R0 – R1	63
12.3	8 relays expansion board 1581 Output 0 – Output 7	63
12.4	German FBP interface board 1583 Output for extinguishing equipment	64
12.5	The 2262 / 2263 unit's Output 0 – Output 3	64
12.6	The 2265 unit's Output 0 – Output 3	64
12.7	The 3361 unit's Output Re0 – Re1	64
12.8	The 3377 unit's Output 0 (siren)	65
12.9	The 3378 unit's Output 0 (sounder)	65
<b>13</b>	<b>Output programming</b>	<b>66</b>
13.1	Type of output	66
13.2	Logic	67
13.3	Not supervised	67
13.4	Time activation	67
13.5	Control expression	69
13.5.1	Trigger conditions	69
13.5.2	Logical operators	72
13.5.3	Control expression examples	73
<b>14</b>	<b>Interlocking function</b>	<b>76</b>
14.1	Programming of interlocking function	76
14.1.1	Interlocking output	76
14.1.2	Interlocking input	76
14.1.3	Interlocking combination	76
14.2	Interlocking indications	78
14.3	Information of interlocking combinations (H9)	78
14.3.1	Display interlocking information (H9/C1)	78
14.3.2	Activate interlocking output (H9/C2)	79
14.3.3	Reset interlocking output (H9/C3)	79
14.3.4	Disable interlocking output (H9/C4)	80
14.3.5	Re-enable interlocking output (H9/C5)	80
14.4	Interlocking control expressions	80

---

<b>15</b>	<b>Fire Door Closing</b>	<b>81</b>
<b>16</b>	<b>Functions / Services / Features</b>	<b>82</b>
16.1	Sensor value	82
16.2	Week average sensor value	82
16.3	Decision value	82
16.4	Alarm algorithms for smoke detectors / Detection levels / Offsets	82
16.4.1	Alarm algorithm / Alternative alarm algorithm	83
16.4.2	Filtering algorithm	84
16.4.3	Smouldering smoke algorithm	86
16.5	Performance factor	87
16.6	Algorithms for analog heat detectors	88
16.6.1	Class A1 algorithm	88
16.6.2	Class A2 S algorithm	89
16.6.3	Class B S algorithm	89
16.7	Algorithm setting via menu H4/U5	89
16.8	Self verification	90
16.9	Minimum / Maximum sensor values	90
16.10	2-zone / address dependence (co-occurrence alarm)	90
16.10.1	2-zone dependence	90
16.10.2	2-address dependence	91
16.11	Delayed alarm	91
16.12	Alert annunciation	92
16.13	Disable alarm points and outputs	93
16.13.1	Disable zone	93
16.13.2	Disable zone / address	93
16.13.3	Disable control output	93
16.14	Disable interlocking output	93
16.15	Disable outputs for routing equipment	94
16.16	Disconnect / Re-connect loop	94
16.17	External time channels 5-12	94
16.18	Test mode	94
16.19	Calibration of supervised outputs	94
16.20	Service signal	95
16.21	Analog smoke detector	95
16.22	Fault signal (fault condition)	96
16.23	User definable text messages	96
16.23.1	Creating the user definable text messages via Win512	97
16.23.2	Downloading texts to Display Unit	99
16.24	Real time clock (RTC)	101
16.25	Printer disable function	101
16.26	Loss of main power source	101
16.27	Win512 Tools menu	101
<b>17</b>	<b>Control unit properties (settings)</b>	<b>103</b>
17.1	Control unit data	103

---

---

17.1.1	General data	103
17.1.2	LED indications by inputs	103
17.1.3	Miscellaneous	104
17.1.4	Selective presentation of alarms	104
17.2	Log events	105
17.3	Log setup	106
17.3.1	General event log	106
17.3.2	Sensor log	106
17.3.3	Communication error log	107
17.4	Control unit information	107
<b>18</b>	<b>System properties (settings)</b>	<b>108</b>
18.1	System data	108
18.1.1	Logical name	108
18.1.2	Alarm delay time	108
18.1.3	Main power loss fault delay time	108
18.1.4	Alarm reset	108
18.1.5	Door closing by time	109
18.1.6	Miscellaneous	109
18.2	Time channels	110
18.3	Time activation outputs	110
18.4	Door open	111
18.4.1	Indication door open affected by	111
18.4.2	Disablement of routing equipment	111
18.5	National holidays	112
18.6	Alarm algorithms	112
18.6.1	Classic smoke detectors' properties	112
18.6.2	Heat detectors' (3308, 3309 and 3316) properties	113
18.6.3	Smoke detectors' (3304 and 3316) properties	113
18.6.4	Multi detector's (3316 & decision algorithm) properties	114
18.7	System information	114
18.8	Time alert annunciation	115
18.9	Two zone dependency	115
<b>19</b>	<b>Compatibility</b>	<b>116</b>
<b>20</b>	<b>Cable types</b>	<b>117</b>
20.1	TLON Network cables	117
20.2	COM loop cables	117
20.3	BS4 loop cables	117
20.4	Ext. FBP / Data converter cables	117
20.5	Conventional zone line cables	117
20.6	Alarm device cables	118
20.7	Other cables	118
<b>21</b>	<b>COM loop cable length</b>	<b>119</b>
<b>22</b>	<b>Current consumption</b>	<b>122</b>
<b>23</b>	<b>Power supply</b>	<b>126</b>

---

23.1	Rectifier	127
23.2	Battery	128
23.3	Form / Table of current consumption	128
<b>24</b>	<b>SW versions</b>	<b>129</b>
<b>25</b>	<b>Technical data</b>	<b>130</b>
<b>26</b>	<b>Limitations</b>	<b>131</b>
26.1	User definable texts	131
26.2	C.i.e. / System	131
<b>27</b>	<b>National regulations</b>	<b>132</b>
<b>28</b>	<b>Drawings / connection diagrams</b>	<b>133</b>
<b>29</b>	<b>Revision history</b>	<b>134</b>

Drawings according to the valid table of drawings.



# 1 Introduction

---

EBL512 Planning Instructions is a document<sup>1</sup> intended to be used by planning engineers as well as service / commissioning engineers.

This document should be read in conjunction with the drawings according to the valid Table of drawings and the EBL512 Operating Instructions.

When planning a fire alarm installation the national regulations have to be obeyed. A lot of detector types can be used. Detector coverage area and detector placing in the room / building, etc. are matters for the planning engineers and are not described in this document.

Due to continual development and improvement, different SW versions are to be found. This document is valid for **SW version 2.1.x**. On the date of revision 2 is x=3.

Since the EBL512 control unit (c.i.e.) is produced for many countries the look, the texts, the functions, etc. may vary.

## Products

Consists of one or more parts (HW) according to a **Product Parts List**. A product has:

- a **type number** (e.g. **1548**)
- an **article number**, often = the type no. and sometimes is a country code added (e.g. **1548SE**)
- a **product name** (e.g. **EBL512 control unit, 128 addresses, without printer**)

## HW

A HW (e.g. a **printed circuit board**) has:

- a **type number** (e.g. **1556**)
- an **article number**, often = the type no. and sometimes is a country code added (e.g. **1556SE**)
- a **product name** (e.g. **Main Board 128 addr.**)
- a **p.c.b. number** (e.g. **9261-3A**) and can also have a configuration (e.g. **CFG: 1**) and a revision (e.g. **REV: 2**)
- sometimes a **SW**

## SW

A SW has:

---

<sup>1</sup> File name: K:\PRO\FIRE\512\Doc\2.1x\MEW00227rev2.doc

- a **version number** (e.g. **V2.1.3**)
- sometimes additional information, such as **Convention** (different functions / facilities), **Language**, **Number of addresses**, etc.

#### **PC SW**

A PC SW is a program used for programming, commissioning, etc. It has a **version number**.

## **1.1 Main differences between EBL512 version 2.0.x and 2.1.x**

### **1.1.1 Convention setting**

It is only possible to set (change) the convention (in the Win512 dialog box "Win512 settings") if "Level 2" is selected (via Tools | Advanced Functions | Level 2) and a Password.

### **1.1.2 Addressable short circuit isolator 2370**

Up to eight isolators per COM loop can be used.

### **1.1.3 DBI (Danish) convention**

- Opened key cabinet will never activate any fire alarm, it will only generate a fault.
- Not acknowledged faults and acknowledged but not corrected faults will turn on the LED "Fault tx activated" and activate the "Fault tx" output(s). If the "Fault tx" output(s) is (are) disabled the LED will still be turned on.
- Only one zone at a time can be set in "Test mode".

### **1.1.4 British Standard Marine Application convention**

- In this convention it is possible to set (change) the alarm algorithms via menu H4/U5, for the analog detectors 3304, 3308 / 3309 and 3316 (in NORMAL mode).
- Alternative alarm algorithm is no longer possible to use.

## **1.2 Main differences between EBL512 version 2.1 and 2.1.1**

### **1.2.1 DBI (Danish) convention**

The difference described in the chapter before, regarding not acknowledged faults and acknowledged but not corrected faults is not valid in version 2.1.1. I.e. there is no difference between the DBI (Danish) convention and the other conventions.

## **1.3 Main differences between EBL512 version 2.1.1 and 2.1.3**

Test of routing equipment is added to the monthly test menu H1.

The program supports the Finnish characters å ä ö Å Ä Ö and the Danish characters å æ ø Å Æ Ø in all texts and printouts.

---

## 2 Definitions / Explanations

---

Definitions / explanations / abbreviations / etc. frequently used or not explained elsewhere in the document.

### 2.1 MFSTech

Matsushita Electric Works Fire & Security Technology AB

### 2.2 Alarm points

Units which can generate fire alarm (in the control unit), i.e. a sensor, a conventional detector, a manual call point, etc.

#### 2.2.1 Smoke detector

Two types of analog and conventional smoke detectors are available: photo electric (optical) and ionization.

#### 2.2.2 Sensor

Sensor = Analog detector

#### 2.2.3 Analog detector

Contains an A/D-converter. The Control Unit pick up the digital values ("sensor values") for each detector individually. All evaluations and "decisions" are then made in the C.U. Analog detectors are addressable – an address setting tool is used for detector types 33xx and a DIL-switch in the ASB (see below) for detectors 2xxx. An analog detector has to be plugged in an ASB.

#### 2.2.4 Analog (Sensor) Base (ASB)

A sensor is plugged in an ASB, which is connected to a COM loop (see below). Sensor Base types 2xxx have a DIL-switch for COM loop address setting.

#### 2.2.5 Conventional detector

Detector with two statuses, normal or fire alarm. The detector contains a closing contact and a series alarm resistor. Some types are plugged in an ADB (see below) or a CDB (see below). Some types are also available as addressable, to be connected to a COM loop (see below).

(Normally plugged in a CDB (see below), connected to a conventional zone line with end-of-line resistor.)

#### 2.2.6 (Conventional Detector) Base (CDB)

A conventional detector is plugged in a CDB, connected to an external line, an addressable zone interface, conventional zone line, etc.

#### 2.2.7 Addressable (Detector) Base (ADB)

A conventional detector is plugged in an ADB, connected to a COM loop (see below).

- 2.2.8 Addressable**  
A unit with a built-in address device, i.e. each unit is individually identified, handled and indicated in the control unit.  
(The unit can consequently be an addressable zone interface, to which one or more conventional "alarm points" can be connected.).
- 2.2.9 Old detector**  
Conventional detector with a closing contact (short circuit; no alarm resistor), or detector with two breaking contacts.
- 2.2.10 External line / Conventional zone line**  
Input (to an ADB / an addressable zone interface or expansion board), intended for one or more conventional alarm points. End-of-line resistor in the last alarm point.
- 2.2.11 ADB input / Addressable zone interface**  
Unit with an input (ext. line / conventional zone line) intended for one or more conventional alarm points. End-of-line resistor in the last alarm point.
- 2.3 Output unit**  
Addressable unit with programmable control outputs. To be connected to a COM loop (see below).
- 2.4 Output / Control output**  
Defined or programmable function. Relay or (supervised / monitored) voltage output, in the C.U. or an output unit.
- 2.5 Short circuit isolator**  
Addressable unit for automatic disconnection of a part of a COM loop (see below) in case of a short circuit on the loop.
- 2.6 Display unit**  
Addressable unit for fire alarm presentation (incl. user definable text messages, if programmed). Connected to a COM loop (see below).
- 2.7 COM loop**  
Loop = a cable, with two wires, to which all the addressable MFSTech units can be connected. It starts in the C.U. and it returns back to the C.U.
- 2.8 BS4 loop**  
Loop = a cable, with two wires, to which all the addressable Autronica (BS100) units can be connected. It starts in the C.U. (EBL512) and it returns back to the C.U.
-

## 2.9 Control Unit (C.U.) / C.I.E.

Control Unit = Control and Indicating Equipment = Unit to which the alarm points are connected. Indicates fire alarm, fault condition, etc. Fire Brigade Panel & Control Panel (see below) included or not included. Printer included or not included.

## 2.10 Fire Brigade Panel (FBP)

Unit intended for fire alarm presentation, etc. for the fire brigade personnel. Can be a part of the control unit (front) or a separate unit (external FBP).

In the ext. FBP, a printer can be included or not included.

## 2.11 Control panel (CP)

A part of the control unit (front), intended for the building occupier, service personnel, etc., to "communicate" with the control unit / system.

## 2.12 System

Several control units connected via a TLON network (co-operating control units).

## 2.13 Network / TLON<sup>®</sup> / LonWorks<sup>®</sup> / Echelon / Node / TLON Conn. board / Gateway / Sub net / Backbone net / Router / Repeater

Brief explanations to the words/expressions to be found in connection with a "network". See also separate TLON Technical description.

TLON<sup>®</sup> = TeleLarm Local Operating Network = a LonWorks<sup>®</sup>- based network<sup>2</sup> for communication between several units/nodes. The protocol is LonTalk and the transmission works with doubly-terminated bus topology (Echelon FTT-10). To connect a control unit to the network, a TLON connection board is plugged in the control unit. (Some old types of control units, not prepared for network connection, have to be connected via a serial interface and a Gateway).

A network can be one sub net (FTT-10) or several sub nets, connected via routers. (In the TLON Network a sub net = a channel.)

Repeaters are used to increase the maximum cable length, node to node, in a network.

---

<sup>2</sup> LonWorks<sup>®</sup> = A "summing-up-name" for the market of Echelon Corporation Inc. technology.

Router or Repeater is the same type of unit (different configuration). All network programming (configuration) are made with the PC program "TLON Manager".

## **2.14 LED**

LED (**L**ight **E**mitting **D**iode) = Yellow, green or red optical indicator ("lamp").

## **2.15 External Indicator (LED)**

A unit with an LED. Connected to an ASB, ADB, CDB or a detector, with a built-in LED. Lit when the built-in LED is lit.

## **2.16 Display / LCD**

LCD (**L**iquid **C**rystal **D**isplay) = Display for presentation of fire alarms, fault messages, etc. Normally alphanumeric characters and backlight.

## **2.17 Door open / Key switch**

In most EBL512 configurations there is a door switch which is activated when the control unit door is open. In some configurations does a key switch replace this door switch.

The LED "Key switch" is indicating "door open" / key switch in position "access".

## **2.18 SSD / Site Specific Data**

This data is unique for each installation. All alarm points, presentation numbers, user definable text messages, programmable outputs, etc. are programmed (configured) in the PC program **Win512** and has to be downloaded in EBL512.

## **2.19 SW / Software / System program**

The SW makes the control unit (the microprocessor) work. It is factory downloaded but a new version can be downloaded in EBL512 on site.

## 3 Overview

---

### 3.1 The EBL512 system

EBL512 is a microprocessor controlled intelligent fire alarm system, intended for analog addressable smoke detectors, as well as conventional detectors and manual call points. Programmable control outputs and output units are available. Up to 512 addresses can be connected to each control unit (c.i.e.).

EBL512 is available in several types, versions and configurations. It can be connected to a TLON network, a "system", with up to 30 independent control units. Each control unit has total access to all information.

EBL512 is designed according to the European standards EN 54, part 2 and 4.

#### 3.1.1 Expansion boards

In the control unit (c.i.e.) it is possible to mount up to six expansion boards. The following types are available:

1580 8 zones expansion board

1581 8 relays expansion board

1582 External FBP interface board<sup>3</sup>

1583 German FBP interface board<sup>4</sup>

1584 Autronica interface board (four BS4 loops)<sup>5</sup>

#### 3.1.2 Printer

Control unit 1549 is equipped with a printer.

In control unit 1548 it is possible to mount a printer 1558.

### 3.2 SW Versions

Due to continual development and improvement, different SW versions can be found. When installing a new control unit in a system with "older" control units, you may have to update the SW in the old control units. It is **highly recommended** to have the same SW version in all control units but the **SW version 2.X.x require the same SW version in all control units.**

---

<sup>3</sup> Max. two 1582 boards per control unit.

<sup>4</sup> Max. one 1583 board per control unit. 1583 board is **not** possible to use in Swedish (SBF) convention.

<sup>5</sup> Max. four 1584 boards per control unit. 1584 board is **only** possible to use in Swedish (SBF) convention.



### 3.3 Backwards compatibility

	EBL512 software version <b>1.xx</b>	EBL512 software version $\geq$ <b>2.X.x</b> <sup>6</sup>
Front <b>Type 1</b> (original)	OK	OK
Front <b>Type 2</b> (EN54)	Not OK	OK

**NOTE!**

In SW version 1.xx, a printer could be connected to the External FBP interface board 1582. This option is deleted in SW version 2.X. Required actions have to be taken.

In PLAN512 / PROJ512, the offset values for pre-warning and heavy smoke alarm are "Control unit settings". In Win512, the corresponding settings (offset pre-warning & offset heavy smoke) are "System properties". Check the values and edit when required.

#### 3.3.1 Upgrade the Site Specific Data (SSD)

EBL512 SW version 2.X.x require SSD downloaded via Win512 version 2.X.x. (Always use the corresponding Win512 version.)

**1a)** SSD made in earlier versions of **Win512** (i.e. **V1.XX.x**) can be used. Open the file in Win512 V2.X.x (File | Open...). In order, not to lose the old file, save the file (File | Save As...) with a new name or in another directory.

**1b)** SSD made in **PLAN512 / PROJ512** version **1.15** (only) can be used. Open the file in Win512 V2.1.x (File | Import Old File...). Save the file (File | Save As...) with a new name (and in another directory).

**2)** Start an SSD validation (Tools | Validate). Correct any "System error", "Warning" or "Convention violation (EN54)" found.

**3)** If there are detectors type 3304 (in 2312 mode) and type 3308 (in 2330 mode) in the installation, they can be upgraded to NORMAL mode<sup>7</sup>. See chapter "Analog Detectors", page 37 and Win512 help, chapter "Upgrade Loop Units". See also the following chapter.

**NOTE!** It is not possible to do the contrary (i.e to downgrade). Double check before upgrading. Only 3304 and 3308 units can be upgraded.

**4)** Save the SSD after required editing. Regarding the SSD download, see the following chapter.

#### 3.3.2 Upgrade the EBL512 control unit (c.i.e.)

**1)** When required, change front Type 1 (original) to Type 2 (EN54).

---

<sup>6</sup> Main board 1556 with two flash memories is required. These p.c.b.:s are marked 9261-3A / **CFG 5** / REV 1, 9261-3A / **CFG 5** / REV 2, 9261-5C / **CFG 5** / REV 1 or 9261-5A / **CFG 5** / REV 1.

<sup>7</sup> Not valid for 3304 detectors with Serial No. 7000001 – 7004527. These detectors must only be used in 2312 and 2330 mode respectively.

2) The new software (SW version 2.X.x) shall now be downloaded (Win512: Tools | Download Software...)<sup>8</sup>. See also Win512 help, chapter "Download Software".

**NOTE!** Before ending the "bootstrap mode" and restart, continue to the following paragraph.

3) Read the "old" EBL512 settings (Win512: Tools | EBL512 Settings...). When required, change the settings, e.g. "Adhesive type" from Type 1 (original) to Type 2 (EN54). Download the settings. See also Win512 help, chapter "EBL512 Settings".

Except the normal fault message after the control unit restart and supervised output faults, the following fault message will be displayed (since the new SSD has not yet been downloaded in the control unit):

```
FAULT: Site specific data (SSD), CU ##  
Date: MM-DD Time: HH:MM
```

4) The new Site Specific Data (SSD), saved in Win512 version 2.X.x, shall now be downloaded (Win512: Tools | Download).

See also Win512 help, chapter "Download".

**NOTE!** If 3304 and 3308 detectors have been upgraded to NORMAL mode in Win512 (see the chapter above), the detectors in the installation will now be automatically upgraded (via the COM loop) before the SSD will be downloaded<sup>9</sup>. Each detector upgraded will be displayed in the Win512 log view<sup>10</sup>.

After the download, the control unit will restart and except the normal fault message after the restart, the following fault message will be displayed:

```
FAULT: Read/write site data (SSW), CU ##  
Date: MM-DD Time: HH:MM
```

This fault will be automatically corrected within a few minutes. All faults in the system have to be acknowledged.

**NOTE!** The SSW will be erased / set to default as follows:

Sensor week average values will be erased and new values will be calculated within two minutes after restart. Passwords will be set to default. All logs will be erased. Alarm counter (only valid for Chinese convention.) will be reset. Supervised outputs calibration will be reset (i.e. calibration has to be performed via menu H5/A1).

---

<sup>8</sup> If a message shows that also download of the language file is required, do so.

<sup>9</sup> This is only valid the very first time the new SSD is downloaded.

<sup>10</sup> If Win512 failed to upgrade a detector, try to set the NORMAL mode via the address setting tool 3314. **NOTE!** Not valid for 3304 detectors with Serial No. 7000001 – 7004527. These detectors must only be used in 2312 and 2330 mode respectively.

## 3.4 Documents

The following documents are available:

- Planning instructions
- Drawings
- Operating instructions

Normally information that is found in one document is not to be found in another document, i.e. the documents complements each other.

## 3.5 Applications

The EBL512 system is intended for small, medium and large installations. The intelligent control units offer the system designer and end user a technically sophisticated range of facilities and functions. Programming (PC SW Win512) and commissioning of the control unit / system is very easy. Start with one control unit and then, when required, add more units. The TLON network makes it possible to install the control units in one building or in many buildings.

## 3.6 PC SW

A number of PC SWs are used together with the EBL512 system.

### 3.6.1 Win512

**Win512** is used for programming and commissioning of one or more control units:

- download / backup of site specific data (SSD)
- download of SW / settings / conventions / configurations / C.U. & system data / etc.
- create and download the user definable text messages shown in the alphanumeric display in the C.U. / ext. FBP and in the Display units.

Win512 shall have the same (or higher) version number as the EBL512 SW version number (e.g. 2.1). Backup require the same version number (in Win512 and EBL512). Old files can be opened and saved in a higher version of Win512 and thereafter downloaded.

### 3.6.2 TLON Manager

**TLON Manager** is used for programming of network data / addresses / etc.

### 3.6.3 NEWTEXT

**NEWTEXT** (DOS based "older" program) can be used to create / download the user definable text messages in the display units connected to the COM loops.

## 4 Control Unit / TLON Network

---

An installation can be **one control unit (c.i.e.)** or up to 30 control units in a system, i.e. a **TLON network**.

In a TLON network each control unit works independent but has nevertheless total access to all information in the system.

NOTE!

In a system, pay attention to the following:

- The alarm points and their "belonging" outputs should normally, for safety reasons, be connected to the same control unit.
- As from **V2.0**, a zone **must not be distributed over the system**, i.e. all alarm points in a zone have to be connected to one c.i.e.
- When the interlocking function is used, the Interlocking Combination (the input, the output and the area) have to be in / connected to one c.i.e. The input and the output can only be used in one combination.

## 5 Control Units 1548 - 1550

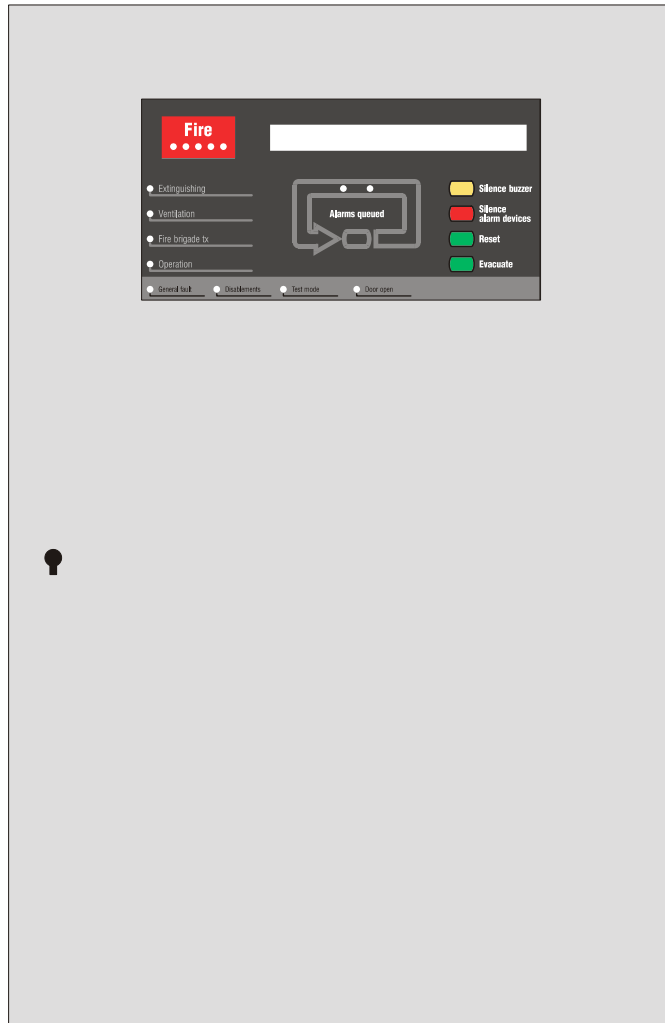

*Figure 1. The EBL512 Control Unit (1548 / 1549). The look may vary according to configuration, etc.*

Depending on country, convention, configuration, etc. the look, language and functions may vary, as well as the max. number of loop units (addresses).

Each control unit has in the basic configuration:

- Four COM loops (0-3) to which the loop units are connected.
- Four programmable supervised voltage outputs (S0-S3).
- Two programmable relay outputs (R0-R1).
- Four programmable inputs (I0-I3).
- Two 24 V DC outputs (power supply of routing equipment and external equipment respectively). Connections and more information, see dwg. 512-44.

- Two not programmable relay outputs for routing equipment (Fire brigade tx and Fault tx respectively). Connections and more information, see dwg. 512-44.
- Built-in power supply (rectifier and batteries). Connections and more information, see dwg. 512-32.

The control unit can also be equipped with expansion boards, TLON network connection board, printer board, etc.

Three types of control units are available:

Type no.	Product	Front (FBP & CP)	Printer
1548	EBL512 Control unit <sup>11</sup> . No expansion boards.	Yes	No <sup>12</sup>
1549	EBL512 Control unit <sup>11</sup> . No expansion boards.	Yes	Yes
1550	EBL512 Control unit <sup>11</sup> . No expansion boards.	No	No

The control unit is housed in a grey metal cabinet. The door has a Plexiglas ahead of the FBP, see Figure 1. When the door is open, you fully see the front (the **Fire Brigade Panel, FBP**, and **Control Panel, CP**), see Figure 2.

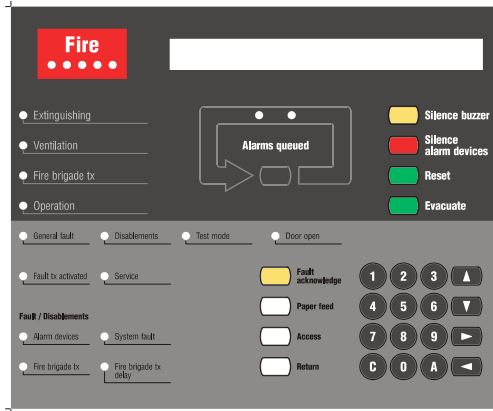

*Figure 2. The EBL512 front; FBP (upper black part) and CP (lower grey part). The look may vary according to country, language, convention and configuration. (English config. shown in the figure).*

The fire brigade personnel use the FBP to see which alarm point / zone(s) having generated fire alarm. In the display (LCD, 2x40 alphanumeric characters), the information displayed on the first row is

<sup>11</sup> Basic configuration can be 128, 256 or 512 addressable loop units.

<sup>12</sup> Afterwards printer board 1558 can be mounted in control unit 1548.

depending on how many alarm points / zones having generated fire alarm (and also convention). On the second row is, for an alarm point or a zone, a user definable text message shown, if programmed. For more information, see EBL512 Operating instructions, V2.1.x.

Required fire brigade personnel manoeuvres can be performed from the FBP.

The CP is used to "communicate" with the system, e.g. for commissioning, monthly tests or maintenance. Access codes for different access levels are required. A keypad is used to get access to the system (a menu tree with main and sub menus) and for different manoeuvres. The CP has several system status LEDs.

NOTE! Regarding LED indicators, keypad / push buttons and access levels, see EBL512 Operating Instructions.

## 5.1 **COM loops**

The control unit has four COM loops (0-3), to which loop units are connected.

Connections according to dwg 512-41, -51 - -55 and -61 - -62.

On each COM loop can a number of COM loop units be connected. Regarding the types and number of COM loop units in relation to the cable length, see dwg 512-01 and -02.

Each COM loop unit has a technical number and each alarm point and zone line input has a presentation number. See EBL512 Operating Instructions for more information.

### **Break or short circuit on a COM loop**

Normally the control unit communicates with the units in one direction, which is automatically changed every 60 seconds.

I.e. a break on a COM loop, between "the last unit" and the control unit, will generate a fault within 60-100 seconds.

By a single break on a loop, between the control unit and the last unit, the following will happen:

- Communication will start in both directions.
- Since it is a single break all units will now be "found" by the control unit. A fault is generated and a fault message is shown:  
FAULT: Cut-off COM-loop x, CU x
- Each 10th minute is an attempt made to communicate in one direction again. When the break is repaired the communication in one direction starts again.
- Regarding Fault acknowledge, see EBL512 Operating Instructions.

By two or more breaks on a loop, between the control unit and the last unit, the following will happen:

- Communication will start in both directions.
- Since it is not a single break all units will not be "found" by the control unit. A fault is generated for each unit not found and fault messages are shown:  
FAULT: No reply techn. no. xxxxxxx
- Each 10th minute is an attempt made to communicate in one direction again. When the breaks are repaired the communication in one direction starts again.
- Regarding Fault acknowledge, see EBL512 Operating Instructions.

By a short circuit on a loop, the following will happen:

- Communication will stop. The loop is disabled.
- A fault is generated and a fault message is shown:  
FAULT: Short-circuit COM-loop x, CU xx
- Each 10th minute is an attempt made to re-enable the loop. When the short circuit is repaired the communication starts again.
- Regarding Fault acknowledge, see EBL512 Operating Instructions.

NOTE! If one or more addressable short circuit isolators are used, the loop will be divided into "segments" (the part between two short circuit isolators or between the control unit and one short circuit isolator). Only the affected segment will be isolated, which will minimise the number of units disabled by a short circuit.

## 5.2 Programmable voltage outputs (S0-S3)

These outputs are supervised (monitored)<sup>13</sup>. Connections according to dwg 512-42. When the connections are done, a calibration has to be done. See EBL512 Operating Instructions chapter "Calibration of supervised outputs (menu H5/A1)".

Each output has to be programmed (Win512) regarding:

- Type
- Logic, i.e. normally low (default) **or** normally high (24 V DC)<sup>14</sup>.
- Activation time and type (steady, pulse delay, etc.)
- Control expression

For more information, see Win512 help or chapter "Programmable outputs", page 62.

## 5.3 Programmable relay outputs (R0-R1)

Connections according to dwg 512-42.

Each output has to be programmed (Win512) regarding:

---

<sup>13</sup> This is default, but via Win512 it is possible to set each output (S0-S3) individually to be not supervised.

<sup>14</sup> A normally high output is not supervised.



- Type
- Logic, i.e. normally open (NO) **or** normally closed (NC) contacts
- Activation time and type (steady, pulse delay, etc.)
- Control expression

For more information, see Win512 help or chapter "Programmable outputs", page 62.

## 5.4 Programmable inputs (I0-I3)

Connections according to dwg 512-43.

Each input has to be programmed (Win512) regarding:

- Trigger condition (Triggered by)
- Logic, i.e. normally open (NO) **or** normally closed (NC) contacts
- Additional information when required: Fault no., Zone, Address and Fault message (Error text)

For more information, see Win512 help or chapter "Programmable inputs", page 57.

## 5.5 Relay outputs for routing equipment (tx)

Not programmable outputs. The outputs can be tested via menu H1, see Operating Instructions.

### 5.5.1 Fire alarm output

This output is normally used for routing equipment (Fire brigade tx). It is a change-over relay contact that will be activated when a fire alarm is generated in the control unit (c.i.e.)<sup>15</sup>. Activated output is (normally) indicated by the LED "Fire brigade tx".<sup>16</sup>

### 5.5.2 Fault output

This output is normally used for routing equipment (Fault tx). It is a change-over relay contact that is normally activated and will be de-activated when a fault is generated<sup>17</sup> in the control unit (c.i.e.)<sup>18</sup>.

---

<sup>15</sup> The output will not be activated if it is disabled via "door open" or via menu H8/S1. See also chapter "Alert annunciation", page 92.

<sup>16</sup> This output and programmable outputs, type of output 4 = Routing equipment, will normally turn on the LED but it is possible to use a programmable input, trigger cond. 8 = Activated routing equipment, to turn on the LED instead.

<sup>17</sup> Also when there is no power supply (e.g. rectifier and battery out of work) and "Watch-dog fault".

<sup>18</sup> The output will not be de-activated if it is disabled via "door open" or via menu H8/S1.

De-activated output (i.e. fault condition) is indicated by the LED "Fault tx activated".

## 6 Expansion boards 1580 – 1584

In each control unit can be mounted up to six expansion boards. See drawings 512-15 & -16.

- Board no. **one** is connected directly to the connection board SBUS connector J5 ("D" type).
- Between board no. one and **two**, a connection cable 1585 (male/male) is required.
- Board no. **three** is connected directly to board no. two.
- Between board no. three and **four**, a connection cable 1586 (female / female) is required.
- Board no. **five** is connected directly to board no. four.
- Between board no. five and **six**, a connection cable 1585 (male/male) is required.

Win 512 is used for the expansion board programming. For more information see the Win512 help.

### 6.1 Expansion board address setting

On each board there are address setting jumpers. For **each type** of board, an address has to be set.

1580: BY1-BY3

1581: BY1-BY3

1582: BY1 (regarding BY4, see description below)

1583: - (BY1-BY3 must not be used for address setting)

1584: BY1-BY2 (BY3 must not be used for address setting)

Each type of board	Board no.	BY1	BY2	BY3
First board	0			
Second board	1	X		
Third board	2		X	
Fourth board	3	X	X	
Fifth board	4			X
Sixth board	5	X		X

X = Jumper set.

(E.g. if only one board of each type is used = each type of board is number 0 = no jumpers shall be set.)

Figure 3. Expansion boards 1580–1584. Address setting table.

## 6.2 **8 zones expansion board 1580**

Up to **six** 1580 boards can be used.

This board has eight inputs for conventional zone lines (i.e. for conventional detectors). In the last unit on each zone line an end-of-line resistor (4K7) has to be connected.

Connections according to dwg 512-46.

Each zone line input has to be programmed (Win512) regarding:

- Type of detectors (i.e. if a short circuit on the line shall generate a fault or a fire alarm)
- Zone number (plus address within the zone when required)
- User definable text message (when required)
- Alert annunciation, steady ON or ON/OFF via a time channel
- Disablement via a time channel
- Fire alarm delay
- Two unit (2-zone) dependent fire alarm (set in the Win512 System dialog box)

## 6.3 **8 relays expansion board 1581**

Up to **six** 1581 boards can be used.

This board has eight programmable relay outputs (0-7).

Connections according to dwg 512-47.

Each output has to be programmed (Win512) regarding:

- Type
- Logic, i.e. normally open (NO) **or** normally closed (NC) contacts
- Activation time and type (steady, pulse delay, etc.)
- Control expression

For more information, see Win512 help or chapter "Programmable outputs", page 62.

## 6.4 External Fire Brigade Panel (FBP) interface board 1582

Up to **two** 1582 boards can be used. Because of high components on the board, a 1582 board always has to be mounted "on top".<sup>19</sup>

This board has an interface for up to eight external FBPs (or data converters)<sup>20</sup>.

All **fire alarm** information (i.e. no pre-warnings and no heavy smoke alarms) shown in the c.i.e. will also be shown in the ext. FBP(s).

**NOTE!** Only the ten first fire alarms will be sent out to the ext. FBPs / Data converters. When **only Data converters** are connected to a 1582 board, jumper BY4 on that board can be set ("on place"), in order to send out all fire alarms to the Data converters.

Connections according to dwg 512-47.

Each board has to be programmed (Win512) regarding:

- Number of ext. FBPs (or data converters)

## 6.5 German FBP interface board 1583

Only **one** 1583 board can be used.<sup>21</sup> (BY1-3 must not be used for address setting).

This board has inputs and outputs for one German FBP (Feuerwehr Bedienfeld).

This board also has inputs and outputs for one German extinguishing equipment (VdS Standard-Schnittstelle "Löschen").

Connections according to dwg 512-50.

Each board has to be programmed (Win512) regarding:

- Activation (Time Activation Output x; Output type 0=steady only), see chapter "Time activation", page 67.
- Control expression (For more information, see Win512 help or chapter "Programmable outputs", page 62.)

---

<sup>19</sup> I.e. when no other boards are used, only one 1582 board can be used.

<sup>20</sup> Ext. FBP incl. printer has a high current requirement. See chapt. "Current consumption", page 122 for more information. Regarding ext. FBPs and Data converters see also chapt. "Other units", page 52.

<sup>21</sup> Can not be used in Swedish (SBF) convention.

## 6.6 Autronica interface board 1584

Up to **four** 1584 boards <sup>22</sup> can be used. (BY3 must not be used for address setting).

Each board is to be programmed (in Win512) and has four BS4 loops (0-3) for Autronica (BS-100) loop units.

On each BS4 loop up to 99 BS4 loop units can be connected. Regarding the BS4 loop units, see separate Autronica documents.

Each BS4 loop unit has a technical number and each alarm point and zone line input has a presentation number. See EBL512 Operating Instructions for more information.

**Each BS4 loop unit is to be programmed** (Win512) regarding:

- Zone number and Address within the zone
- Logical Name (normally not changed)
- Two unit (2-zone/address) dependent fire alarm (some units only)
- Fire alarm delay (some units only)
- Alert annunciation, steady ON or ON/OFF via a time channel (some units only)
- Disablement via a time channel (some units only)
- User definable text message (when required)

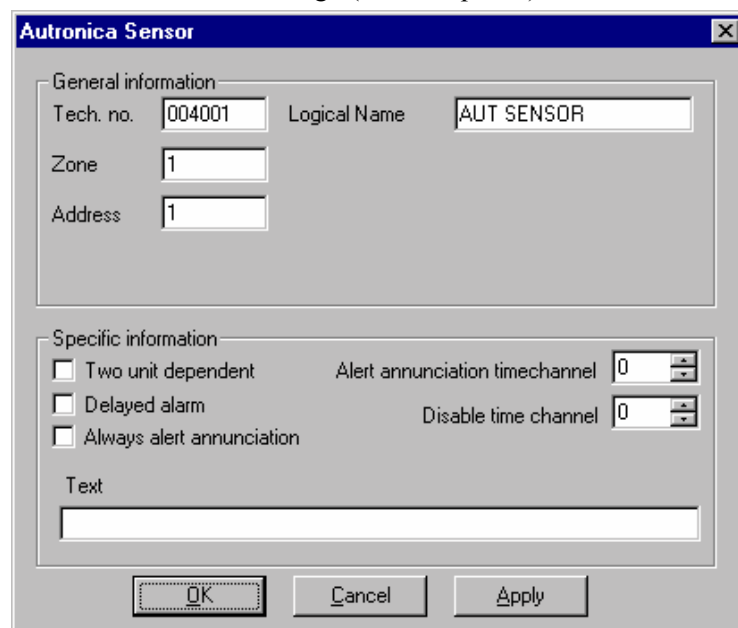

*Figure 4. Win512 "Autronica Sensor" dialog box.*

For more information see Win512 help or separate Autronica documents.

Connections according to dwg 512-48.

---

<sup>22</sup> Can **only** be used in Swedish (SBF) convention.

### **Break or short circuit on a BS4 loop**

Normally the control unit communicates with the units in one direction, which is automatically changed every 60 seconds.

I.e. a break on a BS4 loop, between "the last unit" and the control unit, will generate a fault within 60-100 seconds.

By a single break on a loop, between the control unit and the last unit, the following will happen:

- Communication will start in both directions.
- Since it is a single break all units will now be "found" by the control unit. A fault is generated and a fault message is shown:  
FAULT: Cut-off loop x, BS4 x, CU xx
- Each 10th minute is an attempt made to communicate in one direction again. When the break is repaired the communication in one direction starts again.
- Fault acknowledge, see EBL512 Operating Instructions.

By two or more breaks on a loop, between the control unit and the last unit, the following will happen:

- Communication will start in both directions.
- Since it is not a single break all units will not be "found" by the control unit. A fault is generated for each unit not found and fault messages are shown:  
FAULT: No reply techn. no. xxxxxx
- Each 10th minute is an attempt made to communicate in one direction again. When the breaks are repaired the communication in one direction starts again.
- Fault acknowledge, see EBL512 Operating Instructions.

By a short circuit on a loop, the following will happen:

- Communication will stop. The loop is disabled.
- A fault is generated and a fault message is shown:  
FAULT: Short circ. loop x, BS4 x, CU xx
- Each 10th minute is an attempt made to re-enable the loop. When the short circuit is repaired the communication starts again.
- Fault acknowledge, see EBL512 Operating Instructions.

NOTE! If one or more short circuit isolators are used, the loop will be divided into "segments" (the part between two short circuit isolators or between the control unit and one short circuit isolator). Only the affected segment will be isolated, which will minimise the number of units disabled by a short circuit.

## **7 Printer board 1558**

---

The control unit type 1549 has a factory mounted printer board 1558.

The control unit type 1548 can be provided with a printer board 1558. It is mounted on the inner door backside and is at the same time connected to the main board 1556.

When the printer board 1558 is mounted, the checkbox "Printer board connected to Main board" has to be marked in the Win512 "Control Unit" dialog box.



---

## 8 TLON connection board 1590

---

One TLON connection board 1590 is used in each control unit connected to a TLON network.<sup>23</sup>

This board is mounted on the main board 1556 and the network is connected to the connection board 1555 according to dwg 512-44.

The PC program TLON Manager is used for the required TLON network programming.

**NOTE!** By the TLON network programming, some unique data will be stored in a memory on the 1590 TLON connection board and some unique data will be stored in a memory on the 1556 main board.

After replacing a TLON connection board to another or replacing both a TLON connection board and a main board, do "Replace", "Update" and "Save" in TLON Manager.

After replacing a main board to another (not the TLON connection board), do "Update" and "Save" in TLON Manager.

---

<sup>23</sup> A single (standalone) control unit must not have a TLON connection board 1590 mounted.

## 9 Peripheral devices

---

Alarm points are connected to COM loops<sup>24</sup>, 8 zones expansion boards (1580), Autronica interface boards (1584) and programmable inputs (I0-I3) in the control unit.

Short circuit isolators are connected to COM loops (and BS4 loops).

Sounders, door release magnets, etc. are connected to output units (conn. to the COM loops) and/or in the control unit (to programmable outputs S0-S3 and/or R0-R1 and/or 8 relays expansion boards 1581).

Input devices as key cabinet, timers, external faults, etc. are connected to programmable inputs (i.e. to input units connected on the COM loops and/or to the programmable inputs in the control unit).

Display units are connected to COM loops.

Routing equipment (Fire brigade tx / Fault tx) is normally connected to outputs in the control unit (and when required to programmable outputs).

External Fire Brigade Panels, external Presentation Displays and Data Converters are connected via Ext. FBP interface board(s) (1582).

German external Fire Brigade Panel (*Feuerwehr-Bedienfeld*) is connected to German FBP interface board 1583, which also has a connector for one German Extinguishing equipment (*VdS Standard-Schnittstelle "Löschen"*).

Regarding abbreviations, see chapter "Definitions / Explanations", page 10.

More information, see the Product Leaflet for the device respectively.

### 9.1 COM loop units

Each COM loop can handle up to 128 addressable COM loop units. Depending on the type of units and the number of units the total current consumption will vary and this will affect the cable length. See chapter "Current consumption", page 122 and drawings 512-01 & -02.

NOTE! The control unit can be configured for up to 128, 256 or 512 addresses (COM loop units). Normally this is factory set but can be changed on site (via Win512)<sup>25</sup>. In menu H4/U8 is the current configuration shown. The units should be distributed as even as possible on each COM loop and between the COM loops (0, 1, 2 & 3).

---

<sup>24</sup> Directly or via input units connected to the COM loops.

<sup>25</sup> This action require a separate download password, see EBL512 Operating Instructions.

### Address setting

Each COM loop unit has to have a unique address. This address is for some type of units (see **A** in the Figure 5) set on a DIL switch in the unit respectively and for some type of units (see **AST** in the Figure 5), an Address Setting Tool (3314) is used.

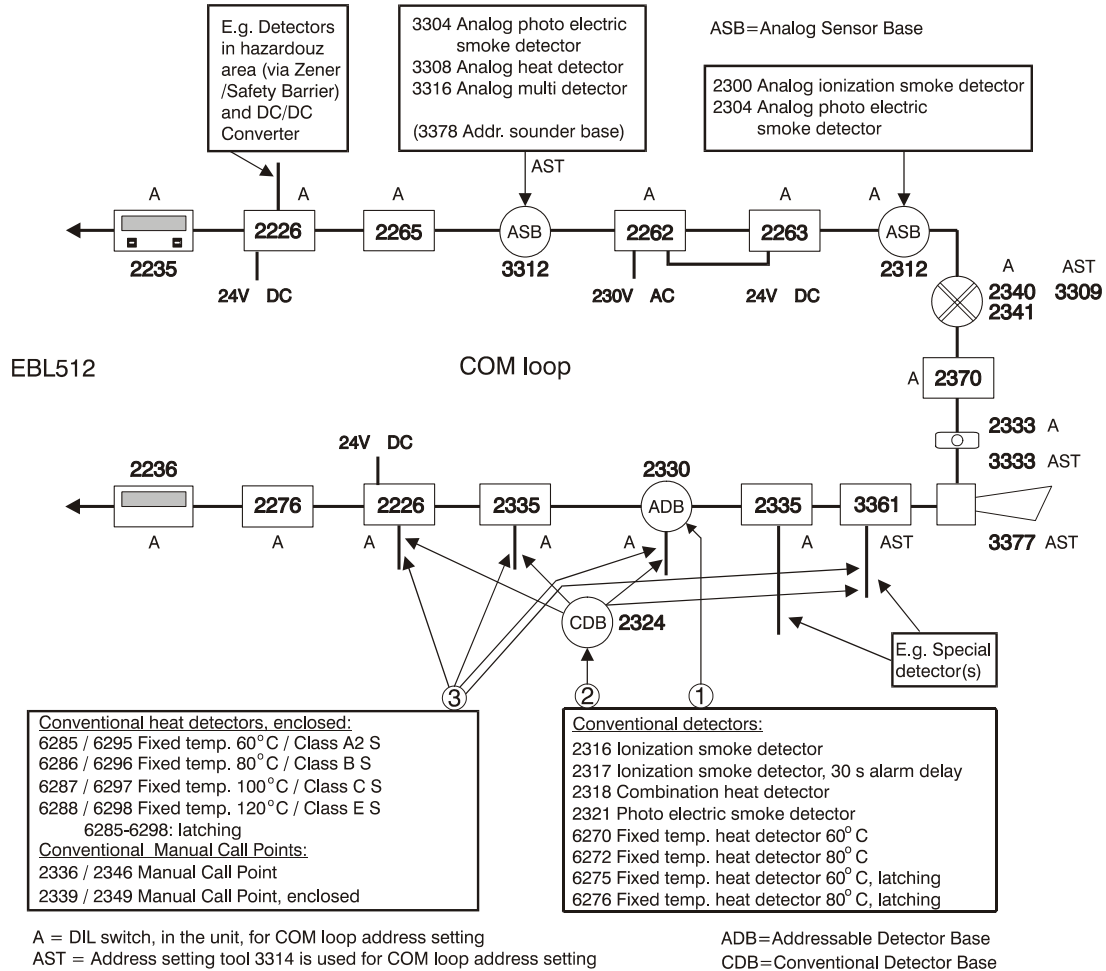

**Figure 5. Units that can be connected to the COM loops. For more information regarding the units, see the following paragraphs.**

- ① = Conventional MFSTech detectors to be plugged in an Addressable Detector Base connected to a COM loop.
- ② = Conventional MFSTech detectors to be plugged in an Conventional Detector Base connected to a conventional zone line input.
- ③ = Conventional MFSTech detectors to be connected to a conventional zone line input.

Conventional MFSTech detectors can also be connected to an 8 zones expansion board (1580) zone line input.

Other conventional detectors, e.g. with only a closing contact (no alarm resistor), can be connected to a zone line input, i.e. to a 2226, 2335, 2330, 3361 or an 8 zones expansion board (1580).

Older conventional detectors, with breaking contacts, can be connected to a 2226 zone line input (loop config.).

### 9.1.1 Input units

Each **COM loop input unit** is to be programmed (Win512), depending on type, regarding:

- Technical number
- Zone number and Address within the zone
- Logical Name (normally not changed)
- Alarm algorithm / Alt. Alarm algorithm (some units only)
- Time Channel for Alt. Alarm algorithm (some units only)
- Two-zone-/unit-dependent fire alarm (some units only)
- Fire alarm delay (some units only)
- Alert annunciation, steady ON or ON/OFF via a time channel (some units only)
- Disablement via a time channel (some units only)
- User definable text message (when required)

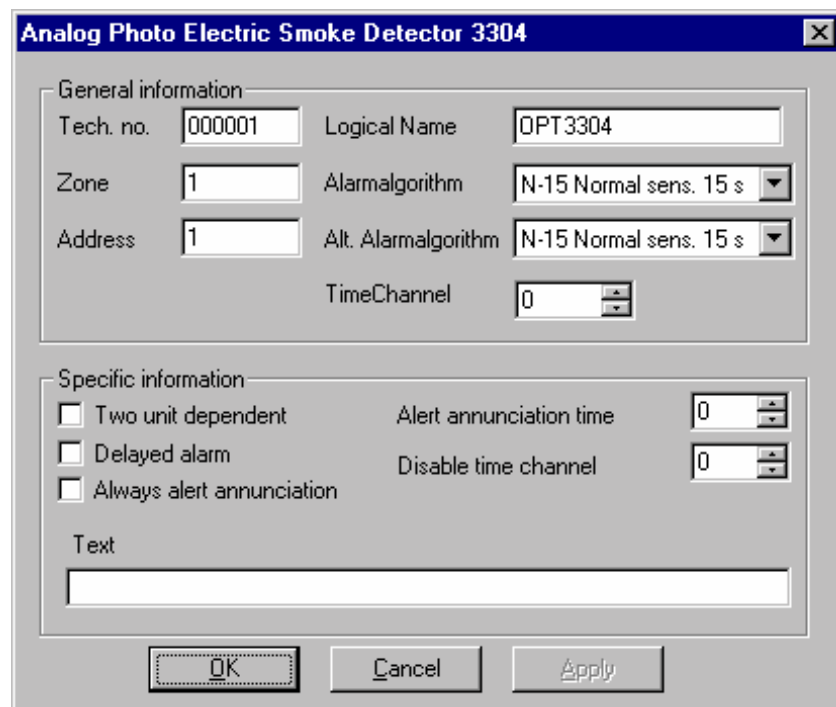

Figure 6. Win512 "Analog photo electric smoke detector 3304" (Optical Sensor) dialog box.

For more information, see Win512 help.

Connections, see dwg. 512-41, -46, -51 - -55.

### 9.1.1.1 Analog Sensor Bases (ASB)

**2312** Analog Base. Analog detectors (Sensors) to be plugged in 2312, see Figure 5, page 33. Built-in LED that is lit to indicate that the plugged sensor has generated fire alarm. Terminals for ext. LED 2216. DIL-switch for address setting.

**3312** Analog Base. Analog detectors (Sensors) to be plugged in 3312, see Figure 5, page 33. Terminals for ext. LED 2216. Prepared for mechanical lock of the detector. Recess for label holder 3391. The base has an address label where the plugged in detector's COM loop address is to be written.

### 9.1.1.2 Addressable Detector Base (ADB)

**2330** Addressable Base.<sup>26</sup> Conventional detectors to be plugged in 2330, see Figure 5, page 33. Built-in LED which is lit to indicate that the plugged detector has generated fire alarm. Terminals for ext. LED 2216 **or** zone line input ("Ext. line"). DIL-switch for address setting.

For conventional detectors to be connected to the zone line input ("Ext. line"), see Figure 5, page 33. End-of-line resistor (10K) is to be connected in the last unit on the zone line.

### 9.1.1.3 Addressable Input Units

**2335** Addressable zone interface.<sup>27</sup> Conventional detectors to be connected to the zone line input ("Zone"), see Figure 5, page 33. End-of-line resistor (10K) is to be connected in the last unit on the zone line. DIL-switch for address setting.

To be mounted in an E1-box / frame (min. 30mm), a Swedish 65mm circular mounting box or a Waterproof box (IP66 / 67) 3362 that also has four compression glands for the cables.

**2226** Addressable zone interface, isolated.<sup>27</sup> Conventional detectors to be connected to the zone line input ("Zone"), see Figure 5, page 33. End-of-line resistor (10K or 3K3) is to be connected in the last unit on the zone line. Old detector types with breaking contacts can also be connected ("Zone Loop"). For more information see dwg 512-54. 2226 require external power supply 24V DC (30mA). DIL-switch for address setting.

To be mounted in an E1-box / frame (min. 50mm), a Swedish

---

<sup>26</sup> In conventions "British Standard Marine Application" and "Chinese", the detector plugged in 2330 has a response time  $\leq 5$  seconds. If "External line with same address" is used, both the detector plugged in 2330 and the detectors on the ext. line have a response time  $\leq 5$  seconds. A response time  $\leq 5$  seconds is not valid if "External line" (with a separate address) is used.

<sup>27</sup> In conventions "British Standard Marine Application" and "Chinese", a fire alarm generated via this unit, has a response time  $\leq 5$  seconds.

65mm circular mounting box. or a Waterproof box (IP66 / 67)  
3362 that also has four compression glands for the cables.

**2276** Addressable 8 inputs unit. Programmable opto-inputs. Bi-polarized opto couplers, 24V DC (6mA), normally high or low. Regarding triggering conditions see chapter "Programmable inputs", page 57. For more information see dwg 512-52. DIL-switch for address setting. To be mounted in an E1-box / frame (min. 30mm).

#### 9.1.1.4

#### **Addressable Manual Call Point**

**2333** Addressable Manual Call Point<sup>28</sup>. A built-in LED<sup>29</sup> will indicate that fire alarm is generated, i.e. the glass is broken. Routine testing can be performed with a test key<sup>30</sup> without breaking the glass. A hinged polycarbonate flap is protecting the glass. DIL-switch for address setting. 2333 is to be surface mounted in the supplied red backbox or flush mounted in a Swedish 65mm circular mounting box.

The 2333 unit is to be replaced with the 3333 unit.

#### 9.1.1.5

#### **Addressable Manual Call Point**

**3333** Addressable Manual Call Point<sup>28</sup>. Conforms with EN54-11. A built-in LED<sup>31</sup> will indicate that fire alarm is generated, i.e. the glass is broken. Routine testing can be performed with a test key<sup>30</sup> without breaking the glass. A hinged polycarbonate flap is protecting the glass. Address is set with an Address setting tool (AST) 3314. The call point has an address label where the programmed address is to be written.

The Address setting tool 3314 is also used for mode setting.<sup>31</sup>

3333 is to be surface mounted in the supplied red backbox or flush mounted in a Swedish 65mm circular mounting box.

The 3333 unit is intended to replace the 2333 unit.

---

<sup>28</sup> In all conventions, the manual call points have a response time  $\leq 5$  seconds.

<sup>29</sup> If switch no. 8 on the point setting DIL-switch is set to ON, the LED will flash each time the control unit communicates with the m.c.p.

<sup>30</sup> Supplied with the m.c.p.

<sup>31</sup> With the address setting tool the call point can be set in:

**NORMAL** mode (EBL512 SW version >2.0 is required) = "3333 mode" and LED mode (see below) to be set in Win512.

**2330** mode = "2333 mode" and "flashing LED mode" (= the LED will flash each time the control unit communicates with the m.c.p.).

**2312** mode = "2333 mode" and "non-flashing LED mode".

**3339** Enclosed Addressable Manual Call Point.<sup>28 32</sup> Like the 3333 unit but another type of front cover and backbox. Only for surface mounting. Ingress Protection rating IP67.

#### 9.1.1.6 **Addressable Conventional Detectors**

**2340** Addressable fixed temperature heat detector, 60°C, enclosed. Built-in LED that is lit to indicate that the detector has generated fire alarm. Terminals for ext. LED 2216. DIL-switch for address setting. The 2340 unit is to be replaced with the 3309 unit in 2330 mode or NORMAL mode, algorithm class A1 or A2 S.

**2341** Addressable fixed temperature heat detector, 80°C, enclosed. Built-in LED that is lit to indicate that the detector has generated fire alarm. Terminals for ext. LED 2216. DIL-switch for address setting. The 2341 unit is to be replaced with the 3309 unit in NORMAL mode, algorithm class B2 S.

#### 9.1.1.7 **Analog Detectors**

**2300** Analog ionization smoke detector. To be plugged in an ASB 2312.

**2304** Analog photo electric smoke detector.<sup>33</sup> To be plugged in an ASB 2312.

**3304** Analog photo electric smoke detector.<sup>33</sup> To be plugged in an ASB base 3312. Built-in LED that is lit to indicate that the detector has generated fire alarm. Prepared for mechanical lock (screw attached). The smoke detector is in Win512 set to one of the six algorithms H-15, H-35, L-15, L-35, N-15 or N-35. The address is set with an Address setting tool (AST) 3314. The detector has an address label where the programmed address is to be written.

The Address setting tool 3314 is also used for mode setting:  
**NORMAL mode:** 3304+3312 and EBL512 SW version  $\geq$  2.0.  
(Set as 3304 in Win512)

**2330 mode:** 3304+3312 is a spare part for 2321<sup>34</sup>+2330<sup>35</sup>).  
(Set as 2330 in Win512)

**2312 mode:** 3304+3312 is a spare part for 2304+2312.  
(Set as 2304 in Win512)

---

<sup>32</sup> This unit might still be under construction.

<sup>33</sup> In convention "British Standard Marine Application", the detector has a response time  $\leq$  10 seconds.

<sup>34</sup> 2321, 2320 or 6217.

<sup>35</sup> NOTE! 2330 has a conventional zone line input ("Ext. Line"). This type of input is not to be found in 3312.

**3308** Analog heat detector. To be plugged in an ASB base 3312. Built-in LED that is lit to indicate that the detector has generated fire alarm. Prepared for mechanical lock (screw attached). In Win512 is set one of the three algorithms for class A1 (static response temp. 54-65°C), A2 S (54-70°C) or B S (69-85°C). The address is set with an Address setting tool (AST) 3314. The detector has an address label where the programmed address is to be written.

The Address setting tool 3314 is also used for mode setting:  
**NORMAL mode**: 3308+3312 and EBL512 SW version  $\geq$  2.0.  
(Set as 3308 in Win512)

**2330 mode**: 3308+3312 is a spare part for 6270<sup>36</sup>+2330<sup>35</sup>, i.e. 3308 works as a class A2 S fixed temperature heat detector, 57°C.

(Set as 2330 in Win512)

**2312 mode**: This mode can **not** be used for 3308.

**3309** Analog heat detector.<sup>32</sup> Enclosed (IP67). Built-in LED that is lit to indicate that the detector has generated fire alarm.<sup>37</sup> Recess for label holder 3391. In Win512 set to one of the three algorithms for class A1 (static response temp. 54-65°C), A2 S (54-70°C) or B S (69-85°C). The address is set with an Address setting tool (AST) 3314. The Address setting tool 3314 is also used for mode setting:

**NORMAL mode**: 3309 and EBL512 SW version  $\geq$  2.0. 3309 with algorithm A1 or A2 S, is a spare part for 2340 and with algorithm B S, a spare part for 2341. (Set as 3309 in Win512)

**2330 mode**: 3309 is a spare part for 2340, i.e. 3309 works as a class A2 enclosed fixed temperature heat detector, 57°C.

(Set as 2330 in Win512)

**2312 mode**: This mode can **not** be used for 3309.

**3316** Analog multi detector.<sup>32</sup> This is an analog smoke detector and an analog heat detector within one detector housing. To be plugged in an ASB base 3312. Built-in LED that is lit to indicate that the detector<sup>38</sup> has generated fire alarm. Prepared for mechanical lock (screw attached). Via Win512 it is programmable, which way the detectors shall operate:

- a) **Two presentation numbers (addresses)**: The detector unit works as two separate detectors. The smoke detector is programmed for one zone-address and the heat detector for another zone-address<sup>39</sup>. (Can be used to disable one of the

---

<sup>36</sup> 6270 or 6275.

<sup>37</sup> An early version of 3309 had also terminals for ext. LED 2216.

<sup>38</sup> I.e. the heat detector and/or the smoke detector.

<sup>39</sup> The zone number has to be the same for both detectors. NOTE! When counting alarm points these "two detectors" are regarded as two alarm points.



detectors during working hours and in control expressions for programmable outputs). The detector unit has one technical number (address) used for programming and fault presentation. For the smoke detector ( $\approx 3304$ ) is in Win512 set one of the six algorithms H-15, H-35, L-15, L-35, N-15 or N-35. For the heat detector ( $\approx 3308$ ) is in Win512 set one of the three algorithms for class A1 (static response temp. 54-65°C), A2 S (54-70°C) or B S (69-85°C).

**b) One presentation number (address):** The detector unit works as one detector and is programmed for one zone-address. The detector unit (actually the heat detector) can detect a methylated spirits fire (EN54-9, test fire TF6; liquid fire), which normally is impossible for a photo electric smoke detector to detect. The detector unit has one technical number (address) used for programming and fault presentation.

It is, via Win512, programmable if the detectors in alt. **b)** shall work with an "OR-functionality" or with a "Decision algorithm":

**b1) OR-functionality:** Either the heat detector **or** the smoke detector will activate fire alarm. This alternative is recommended in most cases. The detector unit has one technical number (address) used for programming and fault presentation. For the smoke detector ( $\approx 3304$ ) is in Win512 set one of the six algorithms H-15, H-35, L-15, L-35, N-15 or N-35. For the heat detector ( $\approx 3308$ ) is in Win512 set one of the three algorithms for class A1 (static response temp. 54-65°C), A2 S (54-70°C) or B S (69-85°C).

**b2) Decision algorithm:**

Fire alarm will be activated if:

temperature (°C) + adjusted smoke value<sup>40</sup>  $\geq 58$ .

Pre-warning will be activated if:

$58 > \text{temperature (°C) + adjusted smoke value} \geq 50$ .<sup>40</sup>

The "Decision algorithm"<sup>41</sup>, See Figure 7, page 40, can be used to reduce so called false alarms (nuisance alarms), because at a normal room temperature, more smoke is required to activate fire alarm than when the room temperature is high (or is rising). By a real fire, the room temperature will rise rather fast and less and less smoke is required to activate fire alarm. Very little smoke require a

---

<sup>40</sup> Adjusted smoke value = obscuration (%/m) x 10. Default heat alarm levels (50 / 58°C) and smoke alarm offsets (50 / 58) can be changed in Win512.

<sup>41</sup> The decision algorithm is a violation to the EN54-7 standard.

"high" temperature to activate fire alarm and very much smoke will activate fire alarm also at a "low" temperature.

The COM loop address for 3316 is set with an Address setting tool (AST) 3314. The detector has an address label where the programmed address is to be written.

The Address setting tool 3314 is also used for mode setting:  
**NORMAL mode:** 3316+3312 and EBL512 SW version  $\geq 2.0$ .  
(Set as 3316 in Win512)

**2330 mode:** This mode can **not** be used for 3316.

**2312 mode:** This mode can **not** be used for 3316.

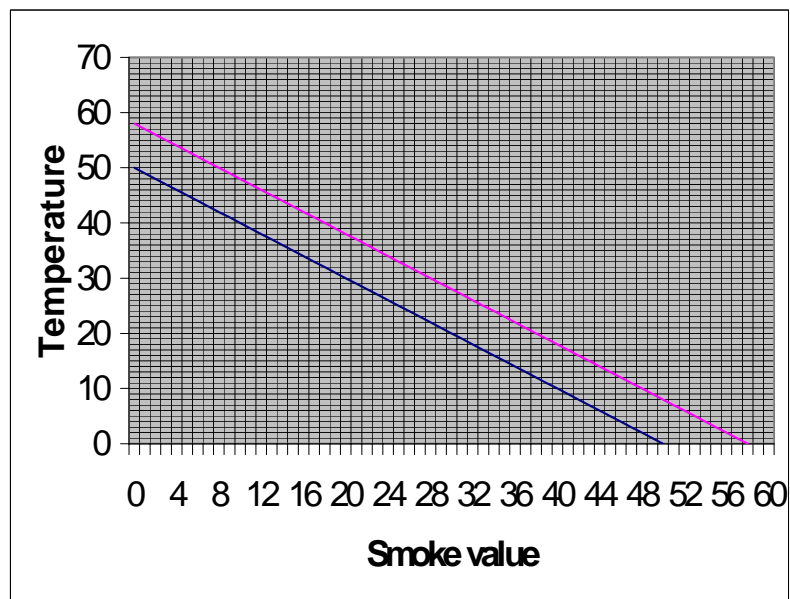

Figure 7. When the calculated value in the decision algorithm exceeds the lower graph, pre-warning will be activated. When it exceeds the upper graph, fire alarm will be activated. Temperature = °C. Smoke value = obscuration (%/m) x 10.

#### 9.1.1.8

#### Conventional Detector Base (CDB)

**2324** Base. Conventional detectors to be plugged in 2324, see Figure 5, page 33. Built-in LED that is lit to indicate that the plugged detector has generated fire alarm. Terminals for ext. LED 2216.

#### 9.1.1.9

#### Conventional Detectors

**2316** Ionization smoke detector. To be plugged in an ADB 2330 or a CDB 2324.

**2317** Ionization smoke detector, 30 sec. alarm delay. To be plugged in an ADB 2330 or a CDB 2324.

**2318** Combination heat detector. Rate-of-rise **and** fixed temperature, 58°C, heat detector. To be plugged in an ADB 2330 or a CDB 2324.

- 2321** Photo electric smoke detector. To be plugged in an ADB 2330 or a CDB 2324.
- 6270** Heat detector. Fixed temperature heat detector, 60°C. To be plugged in an ADB 2330 or a CDB 2324.
- 6272** Heat detector. Fixed temperature heat detector, 80°C. To be plugged in an ADB 2330 or a CDB 2324.
- 6275** Heat detector. Fixed temperature heat detector, 60°C, latching. To be plugged in an ADB 2330 or a CDB 2324.
- 6276** Heat detector. Fixed temperature heat detector, 80°C, latching. To be plugged in an ADB 2330 or a CDB 2324.
- 6285** Heat detector. Fixed temperature heat detector, 60°C, latching, enclosed. Built-in LED that is lit to indicate that the detector has generated fire alarm. Terminals for ext. LED 2216. The 6285 unit is to be replaced with the 6295 unit.
- 6286** Heat detector. Fixed temperature heat detector, 80°C, latching, enclosed. Built-in LED that is lit to indicate that the detector has generated fire alarm. Terminals for ext. LED 2216. The 6286 unit is to be replaced with the 6296 unit.
- 6287** Heat detector. Fixed temperature heat detector, 100°C, latching, enclosed. Built-in LED that is lit to indicate that the detector has generated fire alarm. Terminals for ext. LED 2216. The 6287 unit is to be replaced with the 6297 unit.
- 6288** Heat detector. Fixed temperature heat detector, 120°C, latching, enclosed. Built-in LED that is lit to indicate that the detector has generated fire alarm. Terminals for ext. LED 2216. The 6288 unit is to be replaced with the 6298 unit.
- 6295** Heat detector: Enclosed (IP67). Fixed temperature (60°C) heat detector, class A2 S (static response temp. 54-70°C), latching. Built-in LED that is lit to indicate that the detector has generated fire alarm. Terminals for ext. LED 2216. The 6295 unit is intended to replace the 6285 unit.
- 6296** Heat detector: Enclosed (IP67). Fixed temperature (80°C) heat detector, class B S (static response temp. 69-85°C), latching. Built-in LED that is lit to indicate that the detector has generated fire alarm. Terminals for ext. LED 2216. The 6296 unit is intended to replace the 6286 unit.
- 6297** Heat detector: Enclosed (IP67). Fixed temperature (100°C) heat detector, class C S (static response temp. 84-100°C), latching. Built-in LED that is lit to indicate that the detector has generated fire alarm. Terminals for ext. LED 2216. The 6297 unit is intended to replace the 6287 unit.
- 6298** Heat detector: Enclosed (IP67). Fixed temperature (120°C) heat detector, class E S (static response temp. 114-130°C),

latching. Terminals for ext. LED 2216 (to indicate that the detector has generated fire alarm).

The 6298 unit is intended to replace the 6288 unit.

#### 9.1.1.10

#### Conventional Manual Call Points

**2336** Manual call point. A built-in LED will indicate that fire alarm is generated (i.e. the glass is broken). Functional test can be performed with a special test key<sup>42</sup> without breaking the glass. A hinged polycarbonate flap is protecting the glass. 2336 is to be surface mounted in the supplied red backbox or flush mounted in a Swedish 65mm circular mounting box.

The 2336 unit is to be replaced with the 2346 unit.

**2339** Manual call point. Enclosed (IP55). A built-in LED will indicate that fire alarm is generated (i.e. the glass is broken). Functional test can be performed with a special test key<sup>42</sup> without breaking the glass. A hinged polycarbonate flap is protecting the glass. 2339 is to be surface mounted in the supplied red backbox.

The 2339 unit is to be replaced with the 2349 unit.

**2346** Manual call point.<sup>43</sup> Conforms with EN54-11. A built-in LED will indicate that fire alarm is generated, i.e. the glass is broken. Routine testing can be performed with a test key<sup>42</sup> without breaking the glass. A hinged polycarbonate flap is protecting the glass. 2346 is to be surface mounted in the supplied red backbox or flush mounted in a Swedish 65mm circular mounting box.

The 2346 unit is intended to replace the 2336 unit.

**2349** Manual call point.<sup>43</sup> Enclosed (IP67). Like the 2346 unit but another type of front cover and backbox. Only for surface mounting. The 2349 unit is intended to replace the 2339 unit.

#### 9.1.1.11

#### Accessories

**3314** Address setting tool. Is used to write or read the 33xx units' <sup>44</sup> **COM loop address** (001-127). It is also used to write or read the mode, **NORMAL**, **2330** or **2312** (see the 33xx unit <sup>44</sup> respectively). A connection cable (with crocodile clips / push-on terminals) is attached and can be used when required.

Put the ON/OFF switch in pos. ON and wait for a beep. Plug the detector into 3314 (SA & SB terminals) or when required,

---

<sup>42</sup> Supplied together with the m.c.p.

<sup>43</sup> This unit might still be under construction.

<sup>44</sup> Detectors 3304, 3308, 3309 and 3316 but also the units 3333, 3339, 3361, 3377 and 3378.

use the connection cable <sup>45</sup>.

How to read: Press "READ", wait for a beep and read the address and mode.

How to write: Press "WRITE" and "READ" at the same time to select the mode **and/or** write the address and press "WRITE". Wait for a beep. ("READ" again as a check.)

**3390** Label holder. Can be mounted in the analog base 3312<sup>46</sup>. Intended for a label with "zone-address", "technical number", etc. The label can be read also when the detector is plugged in its base. 100 label holders per packet. Excl. labels.

**3391** Labels for 3390. Self-adhesive white labels for label holder 3390. 10 A4-sheets à 132 labels per packet. For e.g. laser printer usage.

---

<sup>45</sup> Some units have flying leads for easier connection. After use they may be disconnected and thrown away.

<sup>46</sup> Also in the enclosed analog heat detector 3309.

### 9.1.2 Output units (addressable)

Each COM loop output unit is to be programmed (Win512) regarding:

- Technical number
- Logical Name (Normally not changed)
- Type
- Logic, i.e. relay outputs normally open (NO) **or** normally closed (NC) contacts  
alt.  
voltage outputs (24V DC) normally low **or** normally high<sup>47</sup>.
- Activation time and type (steady, pulse delay, etc.)
- Control expression

For more information, see Win512 help or chapter "Programmable outputs", page 62.

Connections, see dwg. 512-61.

**2262** Addressable 4 outputs unit with power supply<sup>48</sup>. The unit has four programmable, supervised 24V DC outputs (0-3) intended for e.g. sounders, etc. It also has two relay **or** 24V DC outputs (HOLD 1 & 2)<sup>49</sup> intended for door release magnets, etc.

2262 is to be connected to 230V AC. It has space for a built-in battery (sealed Lead Acid 2x12V, 6.5Ah) and a 24V DC output for power supply of one 2263. When two or more 2262 / 2263 units are used, two wires can be connected between the units to synchronise intermittent outputs. DIL-switch for address setting. Light grey metal housing, size (HxWxD) 357 x 370 x 150mm. For more information, see chapter "The 2262 / 2263 unit's Output 0 – Output 3", page 64, dwg 512-61 and the Product Leaflet.

**2263** Addressable 4 outputs unit without power supply<sup>48</sup>. The unit is exactly as 2262, only it has no built-in power supply. One 2263 can be power supplied from a 2262 or from an external 24V DC, 4A power supply with battery backup.

**2265** Addressable 4 relays output unit. The unit has four programmable outputs, i.e. four change-over relay contacts for max. 30V, 1A. DIL-switch for address setting. To be mounted in an E1-box / frame (min. 50mm).

---

<sup>47</sup> A normally high output is not supervised.

<sup>48</sup> Up to 20 output units 2262 + 2263 can be programmed per c.i.e.

<sup>49</sup> NOTE! These outputs will be de-activated 10 min. after loss of 230V AC.

### 9.1.3 I / O units (addressable)

**3361** Addressable multipurpose I / O unit.<sup>50</sup> Power supplied via the COM loop. The unit has two programmable inputs:

#### **Monitored input**

**....used as zone line input (Z):** End-of-line capacitor 470 nF mounted in the last unit on the line. Short circuit can activate fault or fire alarm (set via Win512). This input is intended for conventional detectors.

**used as general input (In0):** An input for NC or NO contacts (set via Win512).

**Isolated input (In1):** An optocoupler input (external 24 V DC / 8 mA required). Normally low or high (set via Win512).

The unit has two **programmable** outputs:

**Relay output (Re0):** NC or NO contacts (set via Win512).

**Relay output (Re1):** NC or NO contacts (set via Win512).

Connections and examples, see dwg. 512-57. The unit's dimensions: (L x W x H) 90 x 70 x 32 mm. A plastic protection cover is attached. The cover's dimensions: (L x W x H) 128 x 72 x 35 mm. The unit is intended to be surface mounted and for indoor use in dry premises. When required, the unit can be mounted in a Waterproof box (IP66 / 67) 3362. The unit has an LED to indicate communication to the unit or alarm condition. For more information, see the Product Leaflet. The COM loop address is set with an Address setting tool (AST) 3314. The unit has an address label where the programmed address is to be written.

The Address setting tool 3314 is also used for mode setting:

**NORMAL mode:** 3361 and EBL512 SW version  $\geq$  2.0.

(Set as 3361 in Win512)

**2330 mode:** This mode can **not** be used for 3361.

**2312 mode:** This mode can **not** be used for 3361.

### 9.1.4 Alarm devices (addressable sounders)

**3377** Addressable siren.<sup>50</sup> The unit is a siren connected to the COM loop. It is power supplied via the COM loop. Red ABS plastic housing. For more information, see the Product Leaflet.

The COM loop address is set with an Address setting tool (AST) 3314. The siren has an address label where the programmed address is to be written.

The Address setting tool 3314 is also used for mode setting:

**NORMAL mode:** 3377 and EBL512 SW version  $\geq$  2.0.

(Set as 3377 in Win512)

**2330 mode:** This mode can **not** be used for 3377.

**2312 mode:** This mode can **not** be used for 3377.

---

<sup>50</sup> This unit might still be under construction.

**3378** Addressable sounder base.<sup>50</sup> The unit is mounted between the ASB base 3312 and the ceiling. It is power supplied via the COM loop. For more information, see the Product Leaflet.

The COM loop address is set with an Address setting tool (AST) 3314. The unit has an address label where the programmed address is to be written.

The Address setting tool 3314 is also used for mode setting:

**NORMAL mode:** 3378 and EBL512 SW version  $\geq$  2.0.

(Set as 3378 in Win512)

**2330 mode:** This mode can **not** be used for 3378.

**2312 mode:** This mode can **not** be used for 3378.

### 9.1.5 Display units (addressable)

**Display units** ("alphanumeric displays") are connected to the COM loops. Each Display unit is to be programmed via Win512 ("Add Loop Unit") regarding:

- Technical number
- Logical Name (Normally not changed)

Up to 10 Display units can be programmed per COM loop and up to 20 per c.i.e.

Win512 is also used to create and download, in each display unit separately, the user definable text messages, i.e. each alarm point can have a unique text message in each display unit. (An "older" DOS based PC program, NEWTEXT, can also be used).

**2235** Display unit with alert annunciation. The unit has an alphanumeric display (LCD with two lines à 20 characters<sup>51</sup>) for the fire alarm presentation. The display can have backlight, which requires an external power supply. To reduce the current consumption on the COM loop, the display unit can have an external power supply, see chapter "Current consumption", page 122. Alert annunciation push buttons "ACKNOWLEDGE" (+LED) and "RESET". Built-in buzzer sounds before each text message. MODULAR-contact (6 pole.), used when connecting a PC for downloading the texts. EEPROM for storing the texts (8K as standard and replaceable to 32K).

DIL-switch for address setting. 2235 is to be mounted in an E2-box / frame (min. 50mm).

**2236** Display unit without alert annunciation. The unit is exactly as the 2235 unit, only it has no alert annunciation push buttons (and no LED).

---

<sup>51</sup> A-Z, a-z (in Swedish config. Å, Ä, Ö, å, ä, ö as well), 0-9, space and !"#%&'()\*+,-./:;<=>?@^\_`



Connections, see dwg. 512-62.

#### 9.1.5.1 **Display of the user definable text messages**

When a fire alarm is activated, an individual user definable text message will be displayed in each display unit. If a fire alarm shall not be displayed in any display unit, it shall be set to selective / local function (global is default), see below.

Ten texts can be displayed, via automatic scrolling, every 5<sup>th</sup> second. Before displaying each text, the buzzer sounds (0.5 sec.). The backlight<sup>52</sup> is lit at the first alarm and stays lit until all displayed alarms are reset.

#### 9.1.5.2 **Creating the user definable text messages**

Texts are created and downloaded via **Win512**, see chapter "User definable text messages", page 96.

When the "older" DOS based PC program, **NEWTEXT** is used, the following is valid:

There are three types of texts:

- Free text
- Parameter text
- General alarm text ("Fixed text")

##### **Free text**

A list with the free texts is programmed. Each text consists of two rows à 20 alphanumeric characters. Each presentation number is programmed with a free text from the list. Approx. 196 texts can be programmed. When more texts are required, the 8K EEPROM can be exchanged to a 32K, which gives approx. 810 texts.

Example of a free text:

Fire in the lab. Please vacate the room
--

##### **Parameter text**

One, two or three basic texts can be programmed. Each basic text can consist of two rows à 20 alphanumeric characters. Each basic text can contain a number of parameter fields. Only the digits 0-9 can be used as parameters. Each presentation number programmed together with one of the basic texts (one, two or three) and the parameters to be shown in the parameter field resp. = one parameter text. Approx. 1807 parameter texts can be programmed when only parameter texts

---

<sup>52</sup> If external power supply is connected.

are used. When more parameter texts are required, the 8K EEPROM can be exchanged to a 32K, which gives approx. 7589 parameter texts.

Example of a parameter text:

The basic text is represented by: FIRE, BUILDING, FLOOR, ROOM. The parameter fields are represented by #, \$\$, %%%.

FIRE	BUILDING #
FLOOR \$\$	ROOM %%%

### Free text and parameter text

When both free texts and parameter texts are required, the following formula can be used to calculate / check the number of texts resp.:

$$(F \times 39.25) + (A \times 4.25) \leq E - 512$$

F = Number of free texts (in the free texts list).

A = Total number of presentation numbers that activates free text and parameter text.

E = EEPROM-size, i.e. standard 8K = 8192, or exchanged to 32K = 32768

Example: 220 detectors, 20 addressable manual call points and 10 zones are to activate texts, i.e.  $A=220+20+10=250$ . Standard EEPROM (8K) gives  $E = 8192$ . In the formula:

$$(F \times 35) + (250 \times 4.25) \leq 8192 - 512 \text{ i.e. } F \leq 189 \text{ free texts.}$$

Conclusion: Approx. 189 free texts may be used. The rest,  $250 - 189 = 61$ , will be parameter texts. If there is need for more parameter texts you either have to reduce the number of free texts or exchange the 8K EEPROM to a 32K.

### General alarm text ("Fixed text")

General alarm text is a (programmable) basic text with or without parameter fields.

Note! Only parameter fields = presentation number (zone-address) can be used and only in this order.

Example of general alarm text:

Basic text is represented by: FIRE, ZONE and ADDRESS. The parameter fields are represented by: ###, \$\$.

FIRE	ZONE ###
	ADDRESS \$\$

## 9.1.5.3

### Global or Selective / Local function

#### Global function

Each fire alarm (presentation number), programmed together with a text, will be displayed. All remaining fire alarms will be displayed with the General alarm text.

### Selective / Local function

This function is programmed for each fire alarm (presentation number) that shall not be displayed.

Each fire alarm (presentation number), programmed together with a text, will be displayed. All remaining fire alarms will **not** be displayed.

### 9.1.6 Short circuit isolator (addressable)

Each COM loop short circuit isolator is to be programmed (Win512) regarding:

- Technical number
- Logical Name (Normally not changed)
- Serial Number

Connections, see dwg. 512-53. (See especially about the L wire!)

**2370** Addressable short circuit isolator. In case of a short circuit on a COM loop, the number of disabled units will be minimised. DIL-switch for COM loop address setting. To be mounted in an E1-box / frame (min. 30mm), a Swedish 65mm circular mounting box or a Waterproof box (IP66 / 67) 3362 that also has four compression glands for the cables.

According to the EN54 standard, one 2370 is required per 32 alarm points on a COM loop.

Up to eight 2370 can be used on each COM loop, which gives nine loop segments. Each isolator has to be given a Serial Number, 0-7. The isolators have to be connected consecutively (Serial Number 0-1-2-3-4-5-6-7) in the COM loop A direction.

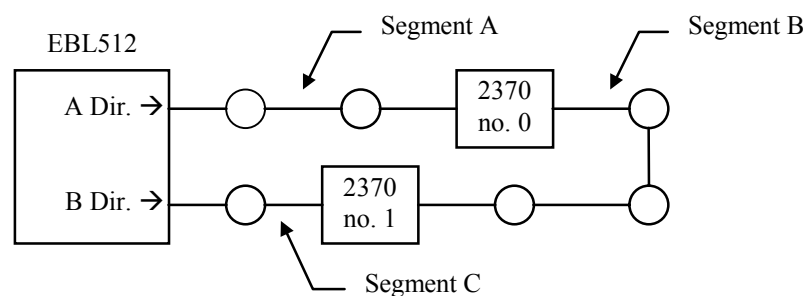

*Figure 8. Two 2370 isolators connected to a COM loop gives three loop segments (Segment A, B and C). If one more 2370 is to be connected between serial no. 0 and 1 in the figure, the new one will be serial no. 1 and the old serial no. 1 will be serial no. 2. (This also require programming via Win512.)*

### Short circuit

A short circuit<sup>53</sup> between the **L** and **C** wires on a COM loop with one or more 2370 isolators connected, will activate one or two 2370 isolators, generate a fault in the c.i.e. and one of the following messages will be shown:

```
FAULT:Sh-circ loop x, CU xx, CU <->ASF0
FAULT:Sh-circ loop x, CU xx,ASF0<->ASF1
FAULT:Sh-circ loop x, CU xx,ASF1<->ASF2
FAULT:Sh-circ loop x, CU xx,ASF2<->ASF3
FAULT:Sh-circ loop x, CU xx,ASF3<->ASF4
FAULT:Sh-circ loop x, CU xx,ASF4<->ASF5
FAULT:Sh-circ loop x, CU xx,ASF5<->ASF6
FAULT:Sh-circ loop x, CU xx,ASF6<->ASF7
FAULT:Sh-circ. loop x, CU xx, ASF7<->CU
FAULT:Sh-circ. loop x, CU xx, ASF6<->CU
FAULT:Sh-circ. loop x, CU xx, ASF5<->CU
FAULT:Sh-circ. loop x, CU xx, ASF4<->CU
FAULT:Sh-circ. loop x, CU xx, ASF3<->CU
FAULT:Sh-circ. loop x, CU xx, ASF2<->CU
FAULT:Sh-circ. loop x, CU xx, ASF1<->CU
FAULT:Sh-circ. loop x, CU xx, ASF0<->CU
```

**CU** = Control Unit (C.i.e.). **ASF** = Addr. short circuit isolator 2370.  
<-> = between (i.e. that segment is disabled).

Each 10<sup>th</sup> minute is an attempt made to de-activate the 2370 isolator(s), i.e. when the short circuit is gone, the segment will be re-enabled again and the isolated units will work normal again.

### Break

A single break on a loop will result in a two way communication on the loop, a fault is generated in the c.i.e. and one of the following messages will be shown:

```
FAULT:Cut-off loop x, CU xx, CU <->ASF0
FAULT:Cut-off loop x, CU xx,ASF 0<->ASF 1
FAULT:Cut-off loop x, CU xx,ASF 1<->ASF 2
FAULT:Cut-off loop x, CU xx,ASF 2<->ASF 3
FAULT:Cut-off loop x, CU xx,ASF 3<->ASF 4
FAULT:Cut-off loop x, CU xx,ASF 4<->ASF 5
FAULT:Cut-off loop x, CU xx,ASF 5<->ASF 6
FAULT:Cut-off loop x, CU xx,ASF 6<->ASF 7
FAULT:Cut-off loop x, CU xx,ASF 7<->CU
FAULT:Cut-off loop x, CU xx,ASF 6<->CU
FAULT:Cut-off loop x, CU xx,ASF 5<->CU
FAULT:Cut-off loop x, CU xx,ASF 4<->CU
FAULT:Cut-off loop x, CU xx,ASF 3<->CU
```

---

<sup>53</sup> Short circuit  $\geq$  1-10 seconds (depending on the cable length and where on the loop the short circuit is located).

FAULT:Cut-off loop x, CU xx,ASF 2<->CU  
FAULT:Cut-off loop x, CU xx,ASF 1<->CU  
FAULT:Cut-off loop x, CU xx,ASF 0<->CU

**CU** = Control Unit (C.i.e.). **ASF** = Addr. short circuit isolator 2370.  
<-> = between (i.e. the break is in that segment). Cut-off = break.  
Each 10<sup>th</sup> minute is an attempt made to communicate in one direction again. When the break is repaired the communication in one direction starts again.

By two or more breaks on a loop, the same is valid as for a single break plus a fault message for each unit not found by the control unit:

FAULT: No reply techn.no. xxxxxx

Each 10<sup>th</sup> minute is an attempt made to communicate in one direction again. When the breaks are repaired the communication in one direction starts again.

## 9.2 BS4 loop units

Each BS4 loop can handle up to 99 addressable BS4 loop units. Regarding the BS4 loop units (Autronica sensors, zone interfaces, manual call points, etc.), see separate Autronica documents.

NOTE! The control unit can be configured for up to 128, 256 or 512 addresses (BS4 loop units). Normally this is factory set but can be changed on site (via Win512)<sup>54</sup>. In menu H4/U8 is the current configuration shown.

### Address setting

Each unit on a BS4 loop has to have a unique address. This is set on a DIL switch in each unit.

## 9.3 Units for Hazardous (Ex) areas

In hazardous (Ex) areas, **Intrinsically Safe (IS)** and approved products are required. Connected to the COM loop is an Addressable IS zone interface. The IS alarm points are connected to a detector interface, i.e. a Galvanic isolator, which is connected to the Addressable IS zone interface. See also dwg. 512-55.

### 9.3.1 Addressable IS zone interface (AIS)

**2821** Addressable IS zone interface. The interface is connected to a COM loop. It has a zone line input. An end-of-line resistor (10K) is to be connected in the last unit on the zone line. It has a DIL-switch for the COM loop address setting. External power supply 24 V DC (30mA) is required. The interface is mounted in a Waterproof box (IP66/67) that also has four compression glands for the cable entries. Box dimensions (L x W x H): 175 x 125 x 75 mm.

---

<sup>54</sup> This action require a separate download password, see EBL512 Operating Instructions.

### 9.3.2 Galvanic isolator

**MTL5061** Galvanic isolator. The isolator is used to connect IS detectors and manual call points to the Addressable IS zone interface zone line input. The isolator has two inputs and two outputs (Channel 1 & 2) and it is mounted in a Waterproof box (IP66/67). Four compression glands for the cable entries and an end-of-line resistor (10K) with an area >230 mm<sup>2</sup> are supplied. Box dimensions (L x W x H): 175 x 125 x 150 mm. BASEEFA classification: EEx ia IIC.

### 9.3.3 Intrinsically Safe mounting base

**YBN-R / 4 IS** Intrinsically Safe mounting base. In the base can be plugged an intrinsically safe conventional smoke or heat detector. The base has terminals for the zone line (in/out) and for an ext. LED.

### 9.3.4 Intrinsically Safe photoelectric smoke detector

**SLR-E-IS** Intrinsically Safe photoelectric smoke detector.  
A conventional photoelectric (optical) smoke detector, to be plugged in the intrinsically safe mounting base. The detector has two built-in LEDs that are lit to indicate that the detector has generated fire alarm. Zone classification: 0, 1 or 2. BASEEFA classification: EEx ia IIC T5, t (amb.)=50°C. Max 20 per zone.

### 9.3.5 Intrinsically Safe heat detector

**DCD-1E-IS** Intrinsically Safe heat detector. A conventional Rate of Rise heat detector, fixed temperature 60°C (class A1), to be plugged in the intrinsically safe mounting base. Two built-in LEDs that are lit to indicate that the detector has generated fire alarm. Zone classification: Category 1 (incl. lower categories). BASEEFA classification: II 1 G EEx ia IIC T5, t (amb.)=55°C. Max 20 per zone.

### 9.3.6 Intrinsically Safe manual call point

**WRZ2 / 4072-470** Intrinsically Safe manual call point. A conventional outdoor manual call point (NO contact and alarm resistor 470 ohms). The call point is connected to an Addressable IS zone interface's zone line input, via a Galvanic isolator. The call point shall be surface mounted with the supplied backbox (IP67) and has two compression glands for the cable entries. BASEEFA classification: Ex N II T6. Max 20 per zone.

## 9.4 Other units

### External LED 2216

Ext. LED 2216 (ext. indicator) is used when a detector is placed out of view or hidden. The LED is lit at the same time as the built-in LED

on a detector / base is lit. Jumpers JP1-JP3 are used to suit different types of detectors. To be mounted in an E1-box / frame (min. 25mm) or a Swedish 65mm circular mounting box.

Connections and jumper settings, see drawings 512-51 - -53.

### **Two inputs / one output unit 2222**

Unit 2222 has two non-polarised optocoupler inputs, one relay output (two change-over contacts) and require an ext. 24V DC power supply. Jumpers BY1-BY2 are used to suit different types of "External LED outputs" (on detectors / bases). Unit 2222 can be used for example when you want fire alarm generated by one or two detectors to activate a relay output. To be mounted in an E1-box / frame (min. 30mm) or a Swedish 65mm circular mounting box.

NOTE! Max. five ext. LED outputs will be activated on a COM loop. A detector may activate fire alarm but the LED / ext. LED may not be turned on, i.e. the 2222 unit's inputs may not be activated.

Connections and jumper settings, see drawings 512-56.

### **Alarm devices (sounders, etc.)**

In MFSTech's product range are no alarm devices intended for the supervised (monitored) voltage outputs in the control unit and/or COM loop output units (2262 / 2263) but connections of other alarm devices are to be according to dwg. 512-42 and -61.

### **Door release magnets**

In MFSTech's product range are no Door release magnets. It is recommended to connect such magnets to the special outputs HOLD 1 & HOLD 2 on the COM loop output units 2262 / 2263, see dwg. 512-61 and chapter "Output units (addressable)", page 44. Door release magnets shall always be provided with a "protection diode" parallel with the coil, see dwg. 512-42.

### **External Fire Brigade Panel / External Presentation Display / Data converter**

Ext. FBPs, ext. presentation displays and data converters are connected to an Ext. FBP interface board 1582 (expansion board) in the control unit (c.i.e.). Regarding the 1582 board, see dwg 512-47 and chapter "External Fire Brigade Panel (FBP) interface board 1582", page 27.

The units have a DIL-switch for address setting. The first unit shall have the address 01, the second unit address 02 and so on<sup>55</sup>. The DIL-

---

<sup>55</sup> A data converter can have address 00 if another unit has address 01. The data converter with the address 00 is only a receiver ("listener"), i.e. no Silence or Reset signals or data converter fault can be transmitted back to the control unit (c.i.e.).

switch has four switches (1-2-3-4). Follow the address setting instructions for the ADB 2330 DIL-switch (addresses 00-15), see dwg. 512-71. The number of ext. FBPs (ext. presentation displays and data converters) is up to eight per 1582 board and has to be programmed in Win512.

The fire brigade panel is a part of the control unit front, see Figure 2, page 20. An external fire brigade panel (ext. FBP) is a separate unit intended to be used by the fire brigade personnel. Required fire brigade personnel manoeuvres can be performed from the FBP. Depending on country (language), convention (functions), configuration, etc. the look may vary.

The external presentation display is a unit for presentation of fire alarms, i.e zone number, address and a user definable text message (if programmed). Depending on country (language), convention (functions), configuration, etc. the look may vary.

A data converter is used to transmit and present fire alarm information in another computerised system. All data converters have open collector outputs, which get activated (low) at the same time as the following LEDs: Fire, Key switch, Fault, Disturbance<sup>56</sup>, Silence, Fire brigade tx, Extinguishing, Ventilation, Zone/Detector not reset, Control off<sup>57</sup>, Fire brigade tx Disabled and Extinguish Disabled respectively. See EBL512 Operating Instructions for more information regarding the LEDs.

To avoid earth fault in the EBL512 control unit when connecting equipment to a data converter, fully isolated (incl. the power supply) short distance modems (RS232 Line Drivers) can be used.

### **External Fire Brigade Panels**

**2425** External Fire Brigade Panel with printer. A light grey metal housing (HxWxD) 335 x 550 x 145mm. The door has a plexi-glass ahead of the FBP. LED indicators and push buttons like the control unit FBP (upper black part of the front), see Figure 2, page 20. Below the FBP part are an LED "Key switch" ("Door open") and an LED "Operation" situated. Regarding the LED indicators and push buttons, see EBL512 Operating Instructions. Normal fire alarm information in the display (no pre-warnings and no heavy smoke alarms). The ten first fire alarms can be displayed / scrolled. (After reset of one of the ten alarms, another alarm can be displayed, if there are more alarms in the system). Built-in printer. Room for orientation drawings.

---

<sup>56</sup> This is not an LED. The output is activated when a fault or a disablement occurs in the system.

<sup>57</sup> This is not an LED. The output is activated when "Control off" is performed via menu H2/B8:



**2426** External Fire Brigade Panel without printer. The unit is exactly as 2425, only it has no printer.

### **External Presentation Display**

**2428** External Presentation Display. A housing made of wood (HxWxD) 172 x 342 x 50mm. LED indicators "Fire", "Alarms queued" and "Operation". Push buttons "Alarms queued Scroll" and "Internal Buzzer Silence". Regarding the LED indicators and push buttons, see also EBL512 Operating Instructions. Normal fire alarm information in the display (no pre-warnings and no heavy smoke alarms). The ten first fire alarms can be displayed / scrolled..

### **Data converters**

Normally the ten first fire alarms will be sent out to the Data converter(s). To have all fire alarms sent out, see chapter "External Fire Brigade Panel (FBP) interface board 1582", page 27, jumper BY4.

**2290** Data converter "BEST". Is used to transmit and present fire alarm information (no pre-warnings and no heavy smoke alarms) in BEST nurse call system<sup>58</sup> (current loop, 4 wires, 20mA to the BEST unit 9573). The data converter p.c.b. and a connection board are mounted in a light grey metal housing, (HxWxD) 357 x 370 x 150mm.

**2291** Data converter "TATECO". Is used to transmit and present fire alarm information (no pre-warnings and no heavy smoke alarms) in Ascom Tateco Paging system (RS232 to the Ascom Tateco unit 940PT/AI<sup>59</sup>). **BRxxx-yy** (xxx=Zone no. and yy=Address) will be shown in **all** pagers and the sound type is **Siren**. If Configuration EPROM is used, also an eight character text can be shown for each Zone no. **or** for each Zone – Address also the programmed user definable text message (shown in the FBP display). Up to sixteen address groups for pagers<sup>60</sup> can be used. Sound type (0=siren, 1=1 beep, - - 9=9 beeps) can be used. When a Configuration EPROM is required, a programming information sheet is required). Housing, dimensions, etc. like 2290.

**2292** Data converter "EBL Talk". Is used to transmit and present fire alarm information (no pre-warnings and no heavy smoke alarms) in another computerised system, e.g. a presentation

---

<sup>58</sup> Normally only used in Sweden. Zone and Address will be interpreted to Ward & Room.

<sup>59</sup> Connections are made on the 940EMC2-module.

<sup>60</sup> Address group = one specific pager, e.g. no. 123 or a group e.g. no. 12X (=120-129) or no. 1XX (=100-199), etc.

system. The 2292 converter offers an open protocol; EBL Talk (RS232). A diskette with instructions and examples can be ordered (free of charge) from MFSTech. The information sent from the control unit is **Fire alarm** (Zone no. and Address, time and user definable text message when programmed), **Fire alarm Reset** and **Status information** (i.e. like the driver outputs plus the following LEDs: Fault tx, Fault tx Disabled, Disabled, Service, Test mode, Power supply Fault, Sounder Fault and System Fault respectively. See EBL512 Operating Instructions for more information regarding the LEDs.

When more than one standalone EBL512 control unit / system are to be connected to one presentation system (PC), one PC COM port has to be used for each EBL512 control unit / system.

Housing, dimensions, etc. like 2290.

### **Boxes**

**3362** Waterproof box (IP66 / 67). A grey polycarbonate box with ingress protection rating IP66 / 67. Four compression glands are included for the cable entries. Dimensions (L x W x H): 175 x 125 x 75 mm. 3362 can be used for:

Addressable multipurpose I/O unit 3361

Addressable zone interface 2335

Addressable zone interface, isolated 2226

Addressable short circuit isolator 2370.

## 10 Programmable inputs

In each control unit are four programmable inputs (I0-I3) available. On the COM loops can Addressable 8 input units 2276<sup>61</sup> be connected, i.e. eight programmable inputs (Input 0-Input 7) per 2276 unit. The addressable multi purpose I/O unit 3361 has two programmable inputs.

Each input is programmed (Win512) regarding:

- Logical name (Normally not changed, but used as Interlocking input it is recommended to add some identity information)
- Triggered by ("Trigger condition")
- Logic
- Fault number (only for trigger cond. no. 11)
- Zone no. and Address (only trigger cond. no. 7 and 18)
- Fault text ("Fault message"; only trigger cond. no. 11)
- Text (only trigger cond. no. 7)
- Time channel no. (only trigger cond. no. 6)

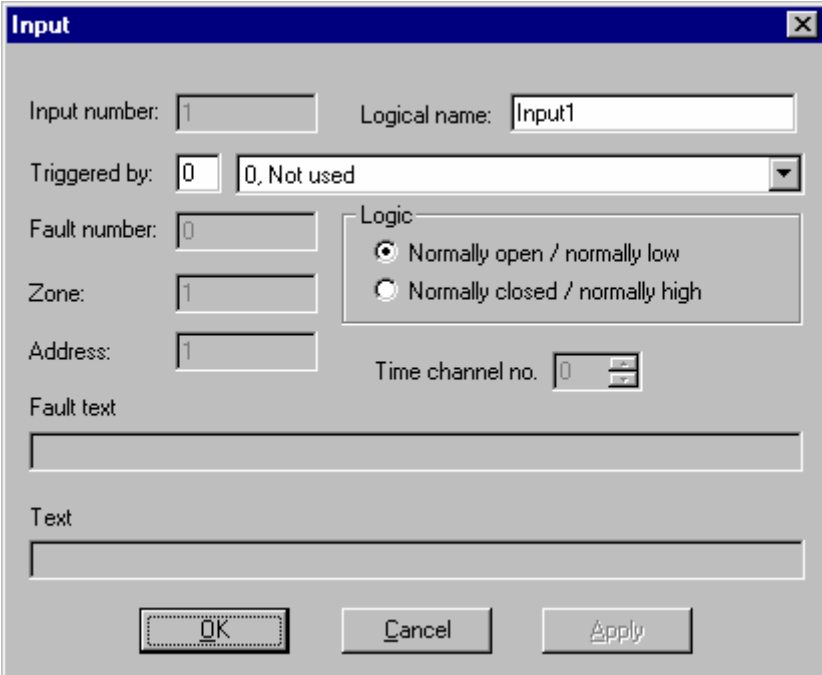

Figure 9. Win512 "Input" dialog box. The different trigger conditions require different additional information.

### 10.1 Control unit Inputs I0 - I3

Connections, see dwg. 512-43.

<sup>61</sup> Also called Unit for programmable inputs.

## **10.2 The 2276 unit's Input0 - Input7**

Connections, see dwg. 512-52.

## **10.3 The 3361 unit's Inputs In0 / Z & In1**

Connections, see dwg. 512-57.

Note! The monitored input can be used as a general input (In0) or used as a zone line input (Z)

# 11 Input programming

---

Input programming is done in Win512. For more information see Win512 help. Each input has to have an individual Trigger condition ("Triggered by") and a Logic. It is not recommended to let two or more inputs have the same trigger condition.

## 11.1 Trigger conditions

The following trigger conditions are available:

0. **Not used**
1. **Alarm Key Cabinet** (one input per control unit)
2. **Alert Annunciation Acknowledge**
3. **Alert Annunciation Reset**
4. **Fault Signal External Power Supply** (one input per control unit)
5. **Fault Signal External Fuses** (one input per control unit)
6. **Time Channel 5 - 12** (one input per time channel per system)
7. **General Fire** (max. 127 per C.U.)
8. **Activated Routing Equipment** (one input per C.U.)
9. **Activated Extinguishing** (one input per C.U.)
10. **Activated Fire Ventilation** (one input per C.U.)
11. **External Fault** (50 inputs per system)
12. **Extinguishing start** <sup>62</sup>
13. **Extinguishing stop** <sup>62</sup>
14. **Interlocking input** (200 inputs per C.U. / 1000 per system)
15. **Loss of main power source to external power supply** (one input per C.U.)
16. **Loss of battery charger to external power supply** (one input per C.U.)
17. **Door Closing Test Input**
18. **Pre-warning Input** (input and corresponding fire alarm input "connected" to the same C.U.)
19. **Zone Line Input** <sup>63</sup>

---

<sup>62</sup> All inputs and outputs involved, have to be connected to the same c.i.e.

<sup>63</sup> Only valid for the Addressable multipurpose I/O unit 3361 input 0, used as zone line input (Z).

### Comments to the trigger conditions:

0. Default. The input do not work.
1. Key cabinet, where the fire brigade store there key to the building. Will activate a Key cabinet alarm. See EBL512 Operating Instructions for more information.
2. Alert annunciation, see EBL512 Operating Instructions for more information.
3. Like 2.
4. Ext. power supply equipment fault output will activate a fault in the EBL512 system. The following fault message will be shown:  
FAULT: External power supply, CU xx
5. Ext. fuses (for the ext. power supply equipment) fault output will activate a fault in the EBL512 system. The following fault message will be shown:  
FAULT: External fuses, control unit xx
6. External clock, timer, key switch, etc. can disable / re-enable alarm points. The function Alert annunciation can be set on / off by a time channel. Control outputs can be set on / off by a time channel.
7. A special detector, push button, etc. can activate a fire alarm in EBL512. Zone no. and Address (+ user definable text).
8. Activated Fire brigade tx feedback to the EBL512 control unit to light up the LED "Fire brigade tx".<sup>64</sup>
9. Activated Extinguishing equipment feedback to the EBL512 control unit to light up the LED "Extinguishing".<sup>64</sup>
10. Activated Ventilation equipment feedback to the EBL512 control unit to light up the LED "Ventilation".<sup>64</sup>
11. Ext. fault will activate a fault in EBL512. An user definable fault message ("Error text") up to 40 characters, will be shown.
12. Used to start a new "countdown", see 13 below.  
Push button: NO, momentary action. One or more push buttons can be used.
13. Output for Extinguishing equipment (type of output = 2) has normally a delayed activation (a "countdown"). This "countdown" will be stopped when an input with trigger condition 13 is activated. To start a new "countdown", see 12 above.  
Push button info: NO, latching action. One or more push buttons can be used. Manual reset of push button(s).
14. A feed-back from the equipment activated by the corresponding interlocking output. Activated input is shown in menu H9/C1. See also chapter "Interlocking function", page 76.

---

<sup>64</sup> One input activated in any control unit, will light up the LED respectively in all control units.

15. "Loss of main power source to external power supply equipment" fault output, will activate a fault in the EBL512 system. It will have the same time delay, as set for the Loss of main power source fault for the c.i.e. The following fault message will be shown:  
FAULT: Mains, ext. power supply, CU xx
16. "Loss of the battery charger to external power supply equipment" fault output, will activate a fault in the EBL512 system. It will have the same time delay, as set for the Loss of main power source fault for the c.i.e. The following fault message will be shown:  
FAULT: Charging ext. power supply CU xx
17. When one or more "Fire door closing" outputs are used, these outputs will be activated for 20 seconds by this trigger condition. NOTE! Only valid for inputs and outputs connected to the same c.i.e.
18. Pre-warning, e.g. from a High Sensitive Smoke Detector's pre-warning output. Zone no. and Address set to the same as the corresponding fire alarm (from the same detector).
19. The Addressable multipurpose I/O unit 3361 monitored input used as zone line input (Z).

## 11.2

### Logic

The logic has to be set.<sup>65</sup>

(•) **Normally open / normally low** Normally open contact or normally low optocoupler input.

( ) **Normally closed / normally high** Normally closed contact or normally high optocoupler input.

---

<sup>65</sup> In the Win512 dialog box "Input".

## 12 Programmable outputs

In each control unit are four programmable voltage outputs (S0-S3) and two programmable relay outputs (R0-R1) available. Up to six 8 relays expansion boards 1581 can be mounted in each control unit. On the COM loops can Addressable 4 output units 2262 / 2263 and Addressable 4 relay outputs units 2265 be connected, i.e. four programmable outputs (Output 0-Output 3) per unit.

On the COM loops can also be connected Addressable Multi purpose I/O unit 3361 with two programmable relay outputs (Re0-Re1) per unit. Addressable siren 3377<sup>66</sup> and Addressable sounder base 3378<sup>66</sup> can also be connected on the COM loops, i.e. the unit has no physical output but the siren and sounder respectively.

Each output is programmed (Win512), when applicable, regarding:

- Logical name (Normally not changed)
- Type
- Logic
- Voltage outputs: Supervised / Not Supervised (in c.i.e. only)
- Activation (time, delay, pulse, etc.)
- Control expression

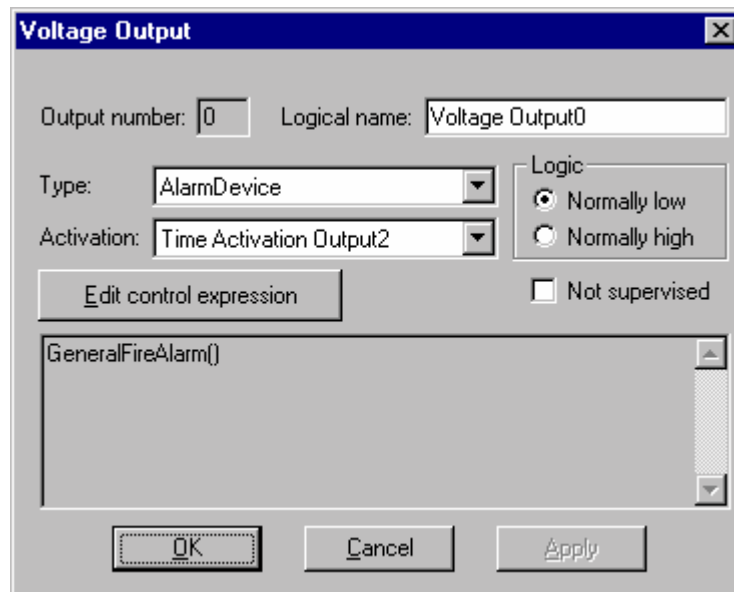

Figure 10. Win512 "Voltage Output" dialog box.

<sup>66</sup> This unit might still be under construction.



## 12.1 Control unit outputs S0 – S3

Each control unit has four programmable, supervised (monitored)<sup>67</sup> voltage outputs:

S0 Supervised (monitored) voltage output, 24V DC

S1 Supervised (monitored) voltage output, 24V DC

S2 Supervised (monitored) voltage output, 24V DC

S3<sup>68</sup> Supervised (monitored) voltage output, 24V DC

Connections and more information, see dwg. 512-42.

## 12.2 Control unit outputs R0 – R1

Each control unit has two programmable relay outputs:

R0 Relay output, NO or NC contacts programmable

R1 Relay output, NO or NC contacts programmable

Connections and more information, see dwg. 512-42.

## 12.3 8 relays expansion board 1581 Output 0 – Output 7

Each 1581 board has eight programmable relay outputs:

Output 0 Relay output, NO or NC contacts programmable

Output 1 Relay output, NO or NC contacts programmable

Output 2 Relay output, NO or NC contacts programmable

Output 3 Relay output, NO or NC contacts programmable

Output 4 Relay output, NO or NC contacts programmable

Output 5 Relay output, NO or NC contacts programmable

Output 6 Relay output, NO or NC contacts programmable

Output 7 Relay output, NO or NC contacts programmable

Connections and more information, see dwg. 512-47.

---

<sup>67</sup> This is default, but via Win512 it is possible to set each output individually as not supervised (not monitored).

A normally high output is not supervised.

<sup>68</sup> The supervised outputs normally have reversed polarity when not activated. In some configurations / conv. S3 has the same polarity activated as supervised, i.e. it should not be used for alarm devices (sounders).

## **12.4 German FBP interface board 1583 Output for extinguishing equipment**

The 1583 board<sup>69</sup> (max. one in each control unit) has one programmable output for activation of German extinguishing equipment. (VdS Standard-Schnittstelle "Löschen"; Löschbefehl).

Connections and more information, see dwg. 512-50.

## **12.5 The 2262 / 2263 unit's Output 0 – Output 3**

Each 2262 / 2263 unit has four programmable, supervised (monitored) voltage outputs:

Output 0 Supervised (monitored) voltage output, 24V DC

Output 1 Supervised (monitored) voltage output, 24V DC

Output 2 Supervised (monitored) voltage output, 24V DC

Output 3 Supervised (monitored) voltage output, 24V DC

Each 2262 / 2263 unit also has two special outputs<sup>70</sup>:

HOLD 1 Relay **or** voltage output, 24 V DC

HOLD 2 Relay **or** voltage output, 24 V DC

Connections and more information, see dwg. 512-61. See also chapter "Output units (addressable)", page 44.

## **12.6 The 2265 unit's Output 0 – Output 3**

Each 2265 unit has four programmable relay outputs:

Output 0 Relay output, NO-C-NC contacts

Output 1 Relay output, NO-C-NC contacts

Output 2 Relay output, NO-C-NC contacts

Output 3 Relay output, NO-C-NC contacts

Connections and more information, see dwg. 512-61.

## **12.7 The 3361 unit's Output Re0 – Re1**

Each 3361 unit has two programmable relay outputs:

Re0 Relay output, NO or NC contacts programmable

Re1 Relay output, NO or NC contacts programmable

Connections and more information, see dwg. 512-53 & -57.

---

<sup>69</sup> Can not be used in Swedish (SBF) convention.

<sup>70</sup> Designed for door release magnets, etc.

## **12.8 The 3377 unit's Output 0 (siren)**

Each 3377 unit has one programmable siren:

Output 0 Siren

Connections and more information, see dwg. 512-53.

## **12.9 The 3378 unit's Output 0 (sounder)**

Each 3378 unit has one programmable sounder:

Output 0 Sounder

Connections and more information, see dwg. 512-53.

## 13 Output programming

---

Output programming is done in Win512. See the Win512 dialog box respectively. For more information see also Win512 help.

### 13.1 Type of output

Some output types can be collective disabled and when activated, an LED will indicate it. The following types are available:

0. **Control**
1. **Fire Ventilation**
2. **Extinguishing**
3. **Alarm Device**
4. **Routing Equipment**
5. **Control, neutral**
6. **Interlocking Output**

#### Comments to the types:

0. Default. General (normal) control output<sup>71</sup>
1. Used to activate fire ventilation equipment<sup>72</sup>
2. Used to activate extinguishing equipment<sup>73</sup>
3. Used for sounders, etc.<sup>74</sup>
4. Used for Fire brigade tx<sup>75</sup>
5. This output will not be collective disabled and not indicated by any LED.
6. This output work together with a corresponding interlocking input. See chapter "Interlocking function", page 76. Activated output is shown in menu H9/C1.

---

<sup>71</sup> Controlled by menu H2/B8 Controls ON / Controls OFF.

<sup>72</sup> Controlled by menu H2/B8 Controls ON / Controls OFF. When activated, the LED "Ventilation" indicates it. (Feedback from the fire ventilation equipment to a programmable input can light up the LED instead).

<sup>73</sup> Controlled by menu H2/B8 Controls ON / Controls OFF. When activated, the LED "Extinguishing" indicates it. (Feedback from the extinguishing equipment to a programmable input can light up the LED instead).

<sup>74</sup> Controlled by menu H2/B9 Alarm devices ON / Alarm devices OFF and by push button "Silence alarm devices". Output fault/disablement is indicated by LED **Fault / Disablements** "Alarm devices" blinking/continuous.

<sup>75</sup> Activated according to its control expression. Disabled like the standard control unit "Fire brigade tx" relay output. When activated, the LED "Fire brigade tx" indicates it. (Feedback from the Fire brigade tx to a programmable input can light up the LED instead). Output fault/disablement is indicated by LED **Fault / Disablements** "Fire brigade tx" blinking/continuous.

## 13.2 Logic

(•) **Normally open / low** Normally open relay contact or normally low voltage output.<sup>76</sup>

( ) **Normally closed / high** Normally closed relay contact or normally high voltage output (24V DC).<sup>77</sup>.

## 13.3 Not supervised

A voltage output is supervised (default). By marking this checkbox the voltage output will be not supervised. (A normally high output can not be supervised.)

## 13.4 Time activation

"Time Activation Output" types (1-10) can be programmed regarding:

- Type (0-6)
- Delay time (when required)
- Pulse length (when required)
- Pulse off (when required)
- De-activation (when required)

The following Time activation output types are available:

0. Steady (continuous)
1. Intermittent
2. One pulse
3. Steady Delayed Activation
4. Intermittent Delayed Activation
5. One pulse Delayed Activation
6. Steady Delayed De-Activation

Regarding the programming, see chapter "Time activation outputs", page 110.

---

<sup>76</sup> The logic is set in the Win512 dialog box "Voltage / Relayed Output".

<sup>77</sup> The logic is set in the Win512 dialog box "Voltage / Relayed Output".

NOTE! A normally high output can not be supervised.

---

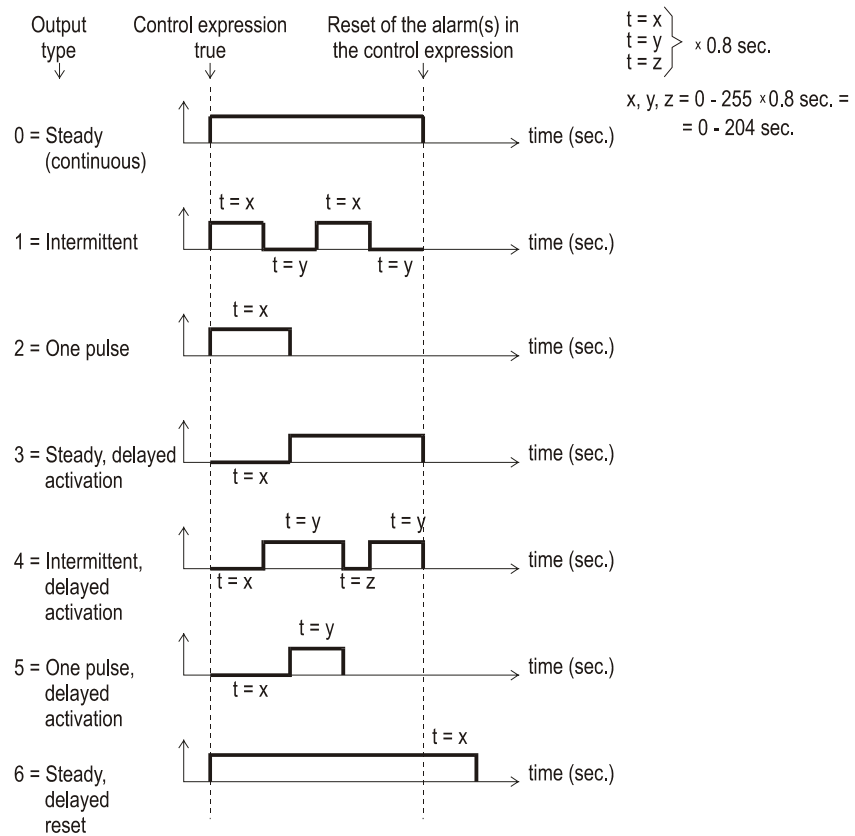

Figure 11. Delay time, Pulse length, Pulse off and/or De-Activation, have to be set for the type respectively.

**NOTE!** The different types can be used together with the different outputs according to the following table:

Output Type	In the Control Unit				On a COM loop				Inter-locking
	S0 - S3	R0 - R1	1581 Board	1583 Board	2265 Unit	2262 2263 Unit	3361 Unit	3377 3378 Unit	
0	X	X	X	X	X	X	X	X	X
1	X	X	--	--	--	XX	--	--	--
2	X	X	--	--	--	--	--	--	--
3	X	X	X	--	X	X	X	X	X
4	X	X	--	--	--	XX	--	--	--
5	X	X	--	--	--	--	--	--	--
6	X	X	X	--	X	X	X	X	--

Figure 12. Programmable outputs in relation to Time Activation Output type. X = Output type is selectable. XX = Output type is selectable but only for **intermittent 0.8 / 0.8 sec.**  
**NOTE!** 1583 board not in Swedish (SBF) convention.

## 13.5 Control expression

Each programmable output has to be given a control expression. It is made by so called Boolean algebra.

Trigger conditions (see "Available functions"), logical "Operators" (**AND**, **OR**, **NOT**) and parentheses are used to make a "control expression" containing up to 40 trigger conditions. See also chapter "Control expression examples" page 73, and Win512 help.

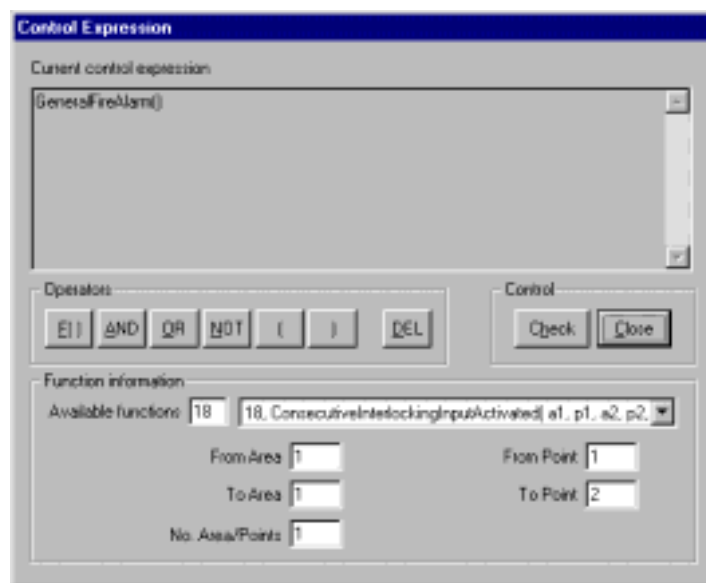

Figure 13. Win512 "Control Expression" dialog box. Note! The number and type of fields in the "Function information" part of the box vary depending on the "Available function" selected.

### 13.5.1 Trigger conditions

Some trigger conditions (see "Available functions") require additional information, see information within parentheses (+nnnnn) after the trigger conditions below.

Some trigger conditions include a sequence. "Quantity" shows the number of alarm points within the sequence that have to be activated to fulfil the trigger condition.

The following trigger conditions are available:

- 1 **Fire Alarm Zone** (+Zone no.)
- 2 **Fire Alarm Zone Address** (+Zone no.+Address)
- 3 **General Fire Alarm**
- 4 **Consecutive Fire Alarm** (sequence) (+start Zone no. and address +stop Zone no. and address +Quantity)
- 5 **Pre Alarm Zone** (+Zone no.)
- 6 **Pre Alarm Zone Address** (+Zone no.+Address)
- 7 **General Pre Alarm**
- 8 **Consecutive Pre Alarm** (+start Zone no. and address +stop Zone no. and address +Quantity)

- 
- 9 **Heavy Smoke Alarm Zone** (+Zone no.)
  - 10 **Heavy Smoke Alarm Zone Address** (+Zone no.+Address)
  - 11 **General Heavy Smoke Alarm**
  - 12 **Consecutive Heavy Smoke Alarm** (sequence) (+start Zone no. and address +stop Zone no. and address +Quantity)
  - 13 **Two Address Dependent Fire Alarm** (+Zone no. +Address)
  - 14 **Two Zone Dependent Fire Alarm** (+Zone no.)
  - 15 **Interlocking Input Area Activated** (+Area no.)
  - 16 **Interlocking Input Area Point Activated** (+Area no. +Point)
  - 17 **General Interlocking Input Activated**
  - 18 **Consecutive Interlocking Input Activated** (sequence) (+start Area no. and point +stop Area no. and point +Quantity)
  - 19 **Fire Brigade Tx Activated**
  - 20 **Fault Tx Activated**
  - 21 **Fire Brigade Tx Disabled**
  - 22 **Zone Disabled** (+Zone no.)
  - 23 **Zone Address Disabled** (+Zone no. +Address)
  - 24 **General Zone Address Disabled**
  - 25 **General Fault**
  - 26 **General Charge Fault**
  - 27 **Reset Pulse Zone Address** (+Zone no. +Address)<sup>78</sup>
  - 28 **Time Channel Activated** (+Time channel no.)
  - 29 **Alert Annunciation Activated**
  - 30 **Alert Annunciation Acknowledged**
  - 31 **Door Open** (+Control unit)
  - 32 **General Door Open**
  - 33 **Key Cabinet Open**
  - 34 **General Control OFF**
  - 35 **General Service Signal**
  - 36 **Alarm Device OFF**
  - 37 **General Encapsulated**
  - 38 **Fire Door Closing** (+Zone no. +Address)

---

<sup>78</sup> Only valid for the c.i.e. outputs (S0-S3, R0 and R1), 2265 outputs and 3361 outputs (i.e. not 2262 and 2263 outputs).



**Comments to the trigger conditions (functions):**

- 1 Fire alarm. For more information, see EBL512 Operating Instructions.
- 2 See 1.
- 3 See 1.
- 4 See 1.
- 5 Pre-warning. For more information, see EBL512 Operating Instructions.
- 6 See 5.
- 7 See 5.
- 8 See 5.
- 9 Heavy smoke / heat alarm. For more information, see EBL512 Operating Instructions.
- 10 See 9.
- 11 See 9.
- 12 See 9.
- 13 One address (in two-address dependence) is in fire alarm state. For more information, see EBL512 Operating Instructions.
- 14 One zone (in two-zone dependence) is in fire alarm state. For more information, see EBL512 Operating Instructions.
- 15 One or more interlocking inputs, in the specified interlocking area, are activated.
- 16 The interlocking input, in the specified interlocking area/point, is activated.
- 17 One or more interlocking inputs are activated.
- 18 One or more interlocking inputs, in the specified range, are activated (from interlocking area no./point to interlocking area no./point).
- 19 Routing equipment output (Fire brigade tx) is activated.<sup>79</sup>
- 20 Routing equipment output (Fault tx) is activated.<sup>80</sup>
- 21 Routing equipment output (Fire brigade tx) is disabled.<sup>81</sup>
- 22 The specified zone is disabled.
- 23 The specified alarm point (zone/address) is disabled.
- 24 One or more alarm points (zone/address) are disabled.<sup>84</sup>
- 25 One or more faults are generated in the system.<sup>82</sup>

---

<sup>79</sup> Indicated by LED "Fire brigade tx". Output can be tested via menu H1.

<sup>80</sup> Indicated by LED "Fault tx activated". Output can be tested via menu H1.

<sup>81</sup> Indicated by LED "**Fault/Disablements** Fire brigade tx".

<sup>82</sup> Indicated by LED "General fault" and/or LED "Fault tx activated".

- 26 Some part(s) of the power supply have generated fault.<sup>82</sup>  
The output(s) will be activated immediately even if the fault respectively is delayed.
- 27 This control expression is true for 5 seconds, whenever a reset pulse is sent to the specified zone/address. The control expression can only be used in the same c.i.e. as the specified zone/address.
- 28 The programmed time channel (1-12) is activated.
- 29 Alert annunciation activated (by any alarm point set to activate this function). For more information, see EBL512 Operating Instructions.
- 30 Alert annunciation activated (by any alarm point set to activate this function) and acknowledged. For more information, see EBL512 Operating Instructions.
- 31 Door open in the specific control unit.<sup>83</sup>
- 32 Door open in any control unit in the system.<sup>83</sup>
- 33 Key cabinet alarm. For more information, see EBL512 Operating Instructions.
- 34 Controls OFF (via menu H2/B8).<sup>84</sup>
- 35 Service signal is activated (by any sensor).<sup>85</sup>
- 36 Alarm devices silenced via any push button "Silence alarm devices" or via menu H2/B9.
- 37 Zone/Detector not reset.<sup>86</sup> (EN54-2 not fulfilled).
- 38 This trigger condition plus the OR operator shall be used for each detector (zone-address) controlling a fire door (normally  $\geq$  two detectors). Type of output has to be "Control, neutral".<sup>87</sup>

### 13.5.2 Logical operators

The logical operators available in Win512 are in priority order:

- ( ) **parentheses**, changes priority order
- NOT** **not**-function (inverts), is written ! in Win512
- AND** **and**-function, is written && in Win512
- OR** **or**-function, is written || in Win512

---

<sup>83</sup> Indicated by LED "Door open".

<sup>84</sup> Indicated by LED "Disablements".

<sup>85</sup> Indicated by LED "Service".

<sup>86</sup> Indicated by LED "Disablements" blinking (0.8 / 0.8 sec.).

<sup>87</sup> In the DBI (Danish) convention, can only the c.i.e. outputs R0-R1 and S0-S3 be used.

### 13.5.3 Control expression examples

In order to understand the possibilities to create control expressions, here follow some AND, OR, NOT and ( ) examples and also some control expression examples.

#### 13.5.3.1 AND

$$a \& \& b \& \& c = y$$

y is true (=1) when all the conditions **a**, **b**, **c** are true, i.e. a=1 and b=1 and c=1 makes y=1. All other combinations makes y=0.

This is also shown in the following table:

a	b	c	y
0	0	0	0
0	0	1	0
0	1	0	0
0	1	1	0
1	0	0	0
1	0	1	0
1	1	0	0
1	1	1	1

#### 13.5.3.2 OR

$$a | b | c = y$$

y is true if at least one of the conditions **a**, **b**, **c** is true, i.e. a=1 or b=1 or c=1 makes y=1.

This is also shown in the following table:

a	b	c	y
0	0	0	0
0	0	1	1
0	1	0	1
0	1	1	1
1	0	0	1
1	0	1	1
1	1	0	1
1	1	1	1

### 13.5.3.3

#### **NOT**

Inverts a condition, e.g.  $!b=!0=1$ .

$a|!b\&\&c=y$

This is shown in the following table:

a	b	c	y
0	0	0	0
0	0	1	1
0	1	0	0
0	1	1	0
1	0	0	1
1	0	1	1
1	1	0	1
1	1	1	1

### 13.5.3.4

#### **Parentheses**

Changes priority order.

$a|!(b\&\&c)=y$  (This is same as the previous but completed with parentheses.)

This is shown in the following table:

a	b	c	y
0	0	0	1
0	0	1	1
0	1	0	1
0	1	1	0
1	0	0	1
1	0	1	1
1	1	0	1
1	1	1	1

### 13.5.3.5

#### **Control expressions**

Here follows some examples (and explanations) to show the principles how to build a control expression with "conditions" and logical operators.):

Example 1

**Output:** Voltage output **S0**  
**Control expression:** Pre Alarm Zone (90)  
**Explanation:** Pre-warning activated in zone no. 90 will activate the output S0.

Example 2

**Output:** Relay output **R1**  
**Control expression:** General Control Off ( ) && !Door Open (01)  
**Explanation:** Controls OFF (via menu H2/B8) will activate the output R1 when the door in control unit 01 is closed (i.e. not open).

Example 3

**Output:** Relay output **R0**  
**Control expression:** Fire Alarm Zone (145) && Fire Alarm Zone (045) && General Fault ( )  
**Explanation:** Fire alarm activated in zone 145 and zone 45 will activate the output R0 when there are one ore more faults in the system at the same time.

Example 4

**Output:** Voltage output **S1**  
**Control expression:** Consecutive Fire Alarm (100,10,100,19,1) || Consecutive Fire Alarm (100,21,100,40,1)  
**Explanation:** Fire alarm activated by one of the alarm points in zone 100 address 10-19 or activated by one of the alarm points in zone 100 address 21-40 will activate the output S1 (i.e. alarm point address 20 in zone 100 will not activate the output S1).

---

## 14 Interlocking function

---

The interlocking function is used to verify that an output really is activated, i.e. by "combining" an output with an input (feed-back from the equipment controlled by the corresponding interlocking output).

### 14.1 Programming of interlocking function

Win512 is used for the programming. Up to 200 Interlocking Combinations per c.i.e. can be used and up to 1000 in a system.

**NOTE!** The Interlocking Combination (the input, the output and the area) have to be in / connected to one c.i.e. The input and the output can only be used in one combination.

#### 14.1.1 Interlocking output

The "Voltage Output" / "Relay Output" dialog boxes are to be used.

**Type:** "Interlocking" is to be selected.<sup>88</sup>

**Activation** ("Time Activation Output"): Type 0 = Steady (continuous) or Type 3 = Steady, delayed activation is to be selected (checked by the "Validate" function in Win512).

**Control Expression** is to be programmed for the output, i.e. for the equipment to be controlled.

Activated output will be indicated in menu H9/C1.

**Logical Name:** It is recommended to add the interlocking combination's presentation number (Area-Point).

#### 14.1.2 Interlocking input

The "Input" dialog box is to be used.

**Triggered by** alternative 14 = Interlocking Input, is to be selected.

Activated input will be indicated in menu H9/C1.

**Logical Name:** It is recommended to add the interlocking combination's presentation number (Area-Point).

#### 14.1.3 Interlocking combination

An interlocking output and an interlocking input are programmed in an interlocking combination to get the interlocking functions.

NOTE!

The interlocking outputs and inputs have to be programmed before the programming of an interlocking combination is possible to do.

(An interlocking combination can have only an output or only an input programmed, e.g. when a user definable text message is wanted to indicate an activated output or input.)

---

<sup>88</sup> Default in Chinese convention.

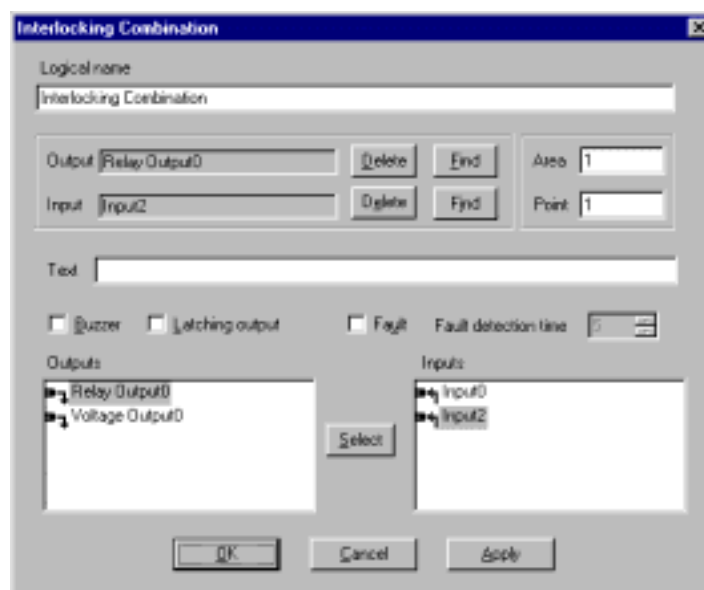

Figure 14. Win512 "Interlocking Combination" dialog box.

**Logical Name:** Displayed in the Win512 Tree and List views. Default is "Interlocking Combination" that can be changed when wanted / required. "Area-Point" will be added in the tree view. "Area-Point" will be shown under "Zone-Address" in the list view.

The **Outputs** list displays all the previous programmed outputs, Type = "Interlocking Output" (contacted to the c.i.e.).

The **Inputs** list displays all the previous programmed inputs with the Triggered by alternative (trigger condition) 14 = "Interlocking Input" (contacted to the c.i.e.). Select one **Output** and one **Input**. Press **Select** and the selected output and input will be shown in the **Output** and **Input** field respectively.

It is possible to **Delete** an output / input (from the field) and to **Find** (go to) the output / input dialog box respectively<sup>89</sup>.

**Area and Point:** Each "Interlocking Combination" is presented as Area-Point (compare with Zone-Address). Area numbers 1-999 are possible and within each Area, Point numbers 1-99 are possible to use. An Area can only be used in one c.i.e.

**Text** = User definable text message to be shown in the menu H9/C1. Can be written in this field or in the "Texts" dialog box, see chapter "Creating the user definable text messages via Win512", page 97.

**Buzzer** checked = activated interlocking input will turn on the c.i.e. buzzer (0.4 / 0.4 sec.)<sup>90</sup>. The buzzer can be silenced. It will be automatically turned on again, if a new interlocking input is activated.

<sup>89</sup> The output / input respectively will also be "selected" (high-lighted) in the tree and list views.

<sup>90</sup> Priority order: Fire alarm – Pre-warning - Telephone (only Chinese convention) - Interlocking - Fault.

**Latching output** checked = Output reset has to be performed via menu H9/C3. (Automatically output reset will not take place when the control expression becomes false.)

**Fault** checked = Fault detection ON.

**Fault Detection Time:** If the input is not activated within 5-255 seconds after the output is activated<sup>91</sup>, a fault will be generated:

```
FAULT: Interlocking input AAA/PP  
Date: MM-DD   Time: HH:MM
```

## 14.2 Interlocking indications

One or more activated Interlocking Combinations (interlocking output and/or input) are indicated in the alphanumeric display in the c.i.e.<sup>92</sup>:

```
Interlocking input/output activated  
See menu H9/C1
```

Disabled interlocking output is indicated by the LED "Disablesments".

### NOTE!

For the **Chinese convention** (+Chinese front) the following is valid:

No indication in the alphanumeric display in the c.i.e. Instead, three LEDs will indicate as follows:

LED "Interlocking input active": One or more interlocking inputs are activated.

LED "Interlocking output active": One or more interlocking outputs are activated.

LED "Interlocking output disabled": One or more interlocking outputs are disabled<sup>93</sup>.

## 14.3 Information of interlocking combinations (H9)

Menu H9 has the following sub menus.

### 14.3.1 Display interlocking information (H9/C1)

See also chapter "Interlocking indications", page 78.

In menu H9/C1 will information be shown as follows:

```
Output AAA/PP activated at HH:MM  
User definable text message.. ..
```

---

<sup>91</sup> After the end of the delay time (if used).

<sup>92</sup> This indication has the lowest priority and will only be shown if the display was empty.

<sup>93</sup> Also indicated by the general LED "Disabled".



OR

Output AAA/PP act HH:MM, input act HH:MM User definable text message.. ..
--

OR

Input AAA/PP activated at HH:MM User definable text message.. ..
---

AAA = Interlocking combination Area

PP = Interlocking combination Point within the Area

HH = Hours

MM = Minutes

Use "↑" "↓" to scroll between several interlocking combinations.

**NOTE!**

For the **Chinese convention** (+Chinese front) the following is valid:

In menu H9/C1 will the following information be shown in **Kanji characters** instead:

- Interlocking output activated.
- Interlocking input activated.
- Total number of activated interlocking inputs.
- Timestamp for activated output and when the input is activated, timestamp for the input instead.
- Interlocking combination, i.e. Area / Point (AAA/PP)
- User definable text message (if programmed)

**14.3.2 Activate interlocking output (H9/C2)**

Even if the control expression for an interlocking output is not fulfilled (true), the output can be manually activated via this menu.

The "Interlocking Combination" (Area / Point) is to be entered to activate the output. The corresponding interlocking input will be "monitored" in the same way as if the output was activated by its control expression.

Reset has to be performed via menu H9/C3.

**14.3.3 Reset interlocking output (H9/C3)**

Activated interlocking outputs are listed here. Use "↑" "↓" to scroll between the "Interlocking Combinations" (Area / Point).

Interlocking output activated via its control expression and latching output selected: The output has to be reset via this menu.

Interlocking output activated via its control expression and latching output not selected: The output can be reset via this menu.

Interlocking output activated via menu H9/C2: The output has to be reset via this menu.

#### **14.3.4 Disable interlocking output (H9/C4)**

Interlocking outputs (i.e. Output Type = Interlocking) can be disabled via menu H9/C4. Note! Not via menu H2/B3. A disabled output will stay in (or return to) the normal condition for the output respectively. The "Interlocking Combination" (i.e. Area / Point) is to be entered to disable the output.

If "000/00" is entered, all interlocking outputs in the system will be disabled.

#### **14.3.5 Re-enable interlocking output (H9/C5)**

Interlocking outputs (i.e. Output Type = Interlocking) can be re-enabled via menu H9/C5. Note! Not via menu H2/B6.

Disabled interlocking outputs are listed in menu H9/C5. Use "↑" "↓" to scroll between the "Interlocking Combinations" (i.e. Area / Point) or type it via the key-pad.

If "000/00" is entered, all interlocking outputs, disabled via menu H9/C4 and "000/00", will be re-enabled.

### **14.4 Interlocking control expressions**

A programmable output control expression can contain "interlocking" trigger conditions ("Functions") numbers 15-18 (see chapter "Control expression", page 69), i.e. one or more outputs can be activated when one or more interlocking inputs are activated.

## 15 Fire Door Closing

---

Programmable outputs <sup>94</sup> can be used for fire door closing. A special trigger condition is available (no. 38 = Fire Door Closing). Type of output is normally "Control, neutral". One or more alarm points can control the output, i.e. the detectors on both sides of the fire door.

In case of one of the following "events", the output will be activated, i.e. the fire door will be closed:

- Fire alarm (any of the programmed detectors)
- Fire alarm in "Test mode" (any of the programmed detectors)
- Fault (i.e. "no answer" from any of the programmed detectors)
- Disablement (any of the programmed detectors, the involved zone(s) or the involved COM loop)
- A definite time every day, if programmed via Win512. The output will be activated for 20 seconds.
- Via a programmable input (trigger condition no. 17 = Door Closing Test Input). The output will be activated for 20 seconds.

### NOTE!

BS4 loops / detectors can not be used for this type of Fire Door Closing.

If a magnet contact is available, is it possible to get a "closed fire door verification" via the Interlocking function. In this case, Type of output has to be "Interlocking output". See also chapter "Interlocking function", page 76.

---

<sup>94</sup> In the DBI (Danish) convention, can only the c.i.e. outputs R0-R1 and S0-S3 be used and Type of output has to be "Control, neutral".

## 16 Functions / Services / Features

---

Some Functions / Services / Features require programming in Win512, see chapter "PC SW", page 17. For more information see also EBL512 Operating Instructions and Win512 help.

How to connect the PC and more information, see EBL512 Operating Instructions chapter "Programming (SSD download)", "New system program (SW) version download" and "EBL512 settings download".

### 16.1 Sensor value

An analog detector is like a "sensor". It detects the environment and the analog values are converted to digital values, "sensor values", which are continuously picked up and evaluated by the control unit (c.i.e.) for each detector individually.

### 16.2 Week average sensor value

A week average sensor value is calculated for each analog smoke detector individually, see chapter "Analog smoke detector", page 95. Regarding the **3304** and **3316** detectors, a **decision value** (see below) is stored each hour instead of a sensor value.

### 16.3 Decision value

The decision value<sup>95</sup> is used to decide if it is normal state, pre-warning, fire alarm or heavy smoke alarm and in the smouldering smoke algorithm (see page 86). The decision value is calculated, see chapter "Filtering algorithm, page 84.

### 16.4 Alarm algorithms for smoke detectors / Detection levels / Offsets

The following is valid for the analog smoke detector types **2200** (ION2200 in Win512), **2202** (OPT2202 in Win512), **2300** (ION2300 in Win512), **2304** (OPT2304 in Win512), **3304 in 2312 mode** (= OPT2304 in Win512) and Autronica analog smoke detectors<sup>96</sup> (AUT SENSOR in Win512).

The following is valid also for the analog smoke detector types **33xx in NORMAL mode** (= OPT3304 / AMD3316 in Win512).

Each detector type has an alarm algorithm and each detector type has three detection levels:

---

<sup>95</sup> Like the sensor value for 22xx and 23xx analog detectors.

<sup>96</sup> Connected to a BS4 loop, i.e. an Autronica interface board 1584 is required in the c.i.e..

1. **fire alarm**<sup>97</sup>
2. **pre-warning** will be activated (if selected in Win512, for each control unit) at a lower level (smaller offset) than for fire alarm, i.e. pre-warning will be activated before fire alarm will be activated.
3. **heavy smoke alarm** will be activated at a higher level (bigger offset) than for fire alarm, i.e. heavy smoke alarm will be activated after fire alarm will be activated.

The pre-warning offset and the heavy smoke alarm level can, for the whole system, be set in Win512, see chapter "Alarm algorithms", page 112. See also Win512 help.

The fire alarm offset can, for the whole system, be set in Win512, see chapter "Alarm algorithms", page 112. See also Win512 help.

**NOTE!** This is not a normal action and a special password is required.

"Pre-warning", "Fire Alarm" and "Heavy Smoke Alarm" can activate programmable outputs respectively, see chapter "Control expression", page 69. See also EBL512 Operating Instructions.

#### 16.4.1

#### Alarm algorithm / Alternative alarm algorithm

The following is valid only for the analog smoke detector types **33xx in NORMAL mode** (=3304 OPT / 3316 AMD in Win512).

In order to reduce nuisance alarms<sup>98</sup>, six different alarm algorithms are available. See Figure 15., page 84. The alarm algorithms are based on:

- Normal, high or low sensitivity
- Normal (15 sec.) or slow (35 sec.) detection time

**Normal sensitivity** Default. Approx. 3.0 % smoke obscuration per meter is required to activate fire alarm.

**High sensitivity** Approx. 2.4 % smoke obscuration per meter is required to activate fire alarm, i.e. less than for normal sensitivity. Can be used when an "early" fire alarm is required.

**Low sensitivity** Approx. 3.6 % smoke obscuration per meter is required to activate fire alarm, i.e. more than for normal sensitivity. Can be used to reduce nuisance alarms<sup>98</sup> but might not fulfil the EN54-7 specifications.

**Normal detection time (15 sec.)** Default. If it was possible to fill a detector with smoke within 1 sec. there is nevertheless a 15 seconds alarm delay. This is a "normal filter" to reduce nuisance alarms.

---

<sup>97</sup> The fire alarm level for each analog detector (sensor) = the current week average sensor value + a fixed fire alarm offset (value), i.e. when the current week average sensor value is re-calculated (and adjusted) the fire alarm level will also be adjusted. The detector's sensitivity is accordingly constant.

<sup>98</sup> So called false / unnecessary alarms.

**Slow detection time (35 sec.).** If it was possible to fill a detector with smoke within 1 sec. there is nevertheless a 35 seconds alarm delay. This is an "extra filter" to reduce nuisance alarms<sup>98</sup> but might not fulfil the EN54-7 specifications.

Each analog smoke detector can have two alarm algorithms programmed (via Win512). One **alarm algorithm** that is normally used (**N-15** is default) and one **alternative alarm algorithm** that is used when a time channel (internal or external) is activated. E.g. normal sensitivity can be used in the night-time and low sensitivity can be used in the daytime (i.e. the alternative alarm algorithm is used to reduce nuisance alarms<sup>98</sup> during working hours).

The actual alarm algorithm can be read in menu H4/U5.

The alarm algorithm parameters can, for the whole system, be set in Win512, see chapter "Alarm algorithms", page 112. See also Win512 help.

### 16.4.2 Filtering algorithm

The filtering algorithm uses the sensor value to calculate the decision value depending on which alarm algorithm that is selected.

The decision value is zero from start. Each time a new sensor value is picked up (sampled) from an analog detector 33xx, this new value is compared with the actual decision value and adjusted as follows:

If the difference, between a new sensor value and the actual decision value is  $\leq$  "X", the decision value is set equal to the new sensor value. If the difference is  $>$  "X", the decision value is increased or reduced by "X".

The decision value will consequently not be increased / decreased with a value exceeding the "X" value even if a sensor value is much higher / lower.

"X" = The Step Value, which is different depending on the sensitivity and detection time, i.e. the alarm algorithm, see Figure 15.

Analog detector	Normal detection time (15sec.)			Slow detection time (35sec.)		
	<b>H-15</b> (High sensitivity)	<b>N-15</b> (Normal sensitivity)	<b>L-15</b> (Low sensitivity)	<b>H-35</b> (High sensitivity)	<b>N-35</b> (Normal sensitivity)	<b>L-35</b> (Low sensitivity)
3304	X=4	X=5	X=6	X=2	X=2	X=2
3316	X=8	X=10	X=12	X=4	X=4	X=4

*Figure 15. The six alarm algorithms. Default is alarm algorithm N-15, i.e. normal detection time (15 sec.) and normal sensitivity. X=The step value. (The L-15, H-35, N-35 and L-35 algorithms might not fulfil the EN54-7 specifications.)*

Sensor/Decision values

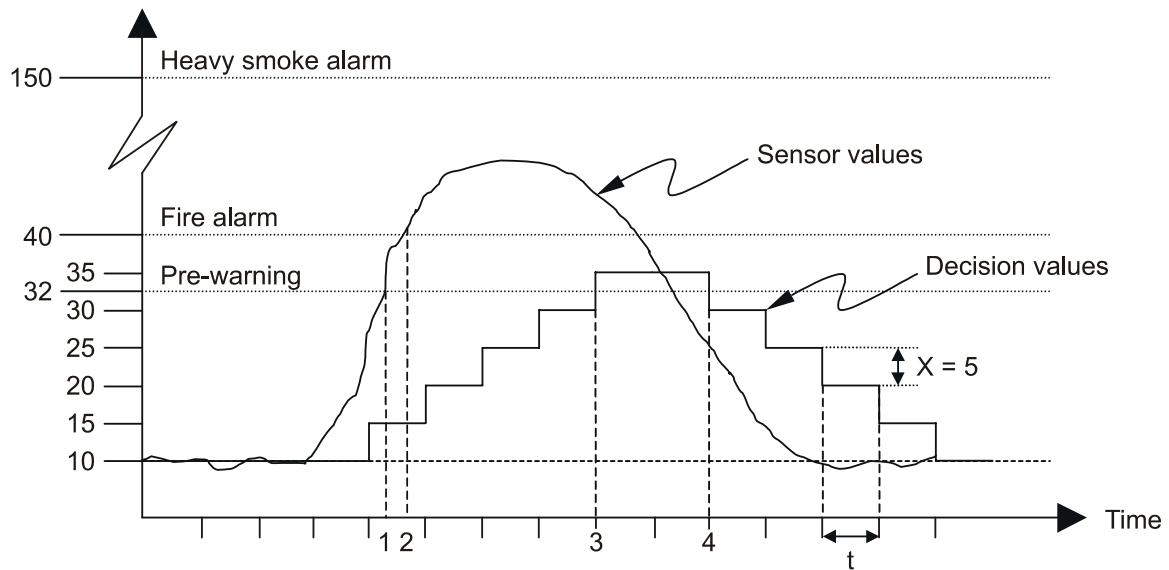

*Figure 16. An example of the filtering algorithm with the alarm algorithm "N-15" selected, i.e. the step value  $X = 5$ .*

Explanations to the figure:

Analog smoke detector 3304. Normal detection time (15sec.) and normal sensitivity (i.e. alarm algorithm "N-15") results in  $X = 5$ . The detector polling time  $t \approx 2.56$  sec. The week average sensor value is "10", i.e. the pre-warning level is adjusted to "32" ( $22+10$ ) and the fire alarm level to "40" ( $10+30$ ).

The sensor values and decision values are approx. equal ("10"), until the polling when the sensor value becomes approx. "27". Since  $27-10 > X=5$ , the decision value ("10") is increased by  $X=5$  to "15". Next polling the sensor value is approx. "45", i.e. the decision value ("15") is increased by  $X=5$  to "20", and so on.

When the sensor value is reduced to approx. "25" the decision value is set to "30", because  $35-25=10 > X=5$ , i.e. the decision value ("35") is reduced by  $X=5$  to "30", and so on.

1. The sensor value has here reached the pre-warning level but nothing will happen since the decision value has not reached the pre-warning level.
2. The sensor value has here reached the fire alarm level but nothing will happen since the decision value has not reached the fire alarm level.
3. The decision value has here reached the pre-warning level and pre-warning is activated.
4. The decision value is here below the pre-warning level and the pre-warning is automatically reset.

### 16.4.3 Smouldering smoke algorithm

The smoke from a smouldering fire brings the sensor value to rise very slowly. The fire can last for hours and sometimes days. To be able to detect such a fire at an "early" stage, a smouldering smoke algorithm is used.

The smouldering smoke algorithm is depending on and works parallel with the selected alarm algorithm, i.e. the smouldering smoke algorithm can affect the pre-warning and fire alarm levels, see below.

If the decision value has been over the smouldering level for **7 minutes**, the pre-warning and fire alarm levels are lowered:

- The pre-warning level is lowered to a level right between the original pre-warning level and the smouldering level.
- The fire alarm level is lowered to a level right between the original fire alarm level and the pre-warning level.

If the decision value has reached the pre-warning level, but not the fire alarm level, after **additional 90 minutes**, the pre-warning and fire alarm levels are lowered again:

- The pre-warning level is lowered to the original smouldering level.
- The fire alarm level is lowered to the original pre-warning level.

The smouldering smoke algorithm is aborted and the pre-warning and fire alarm levels are restored to their original values if:

- The decision value becomes lower than the smouldering level.
- The decision value, after the **90 minutes**, has not reached the pre-warning level.
- The decision value, after the **90 minutes** and **additional 120 minutes**, has not reached the fire alarm level.

The smouldering offset can, for the whole system, be set in Win512, see chapter "Alarm algorithms", page 112.

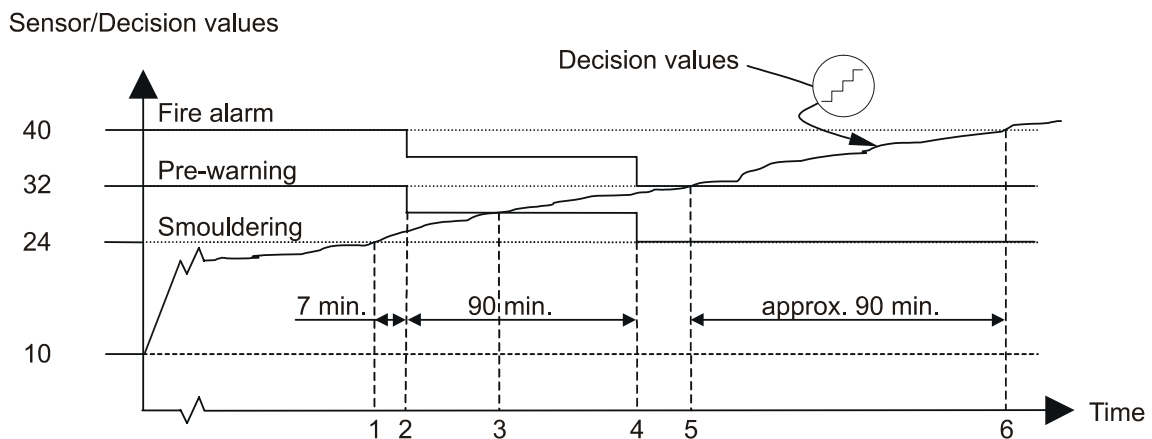

*Figure 17. An example of the smouldering smoke algorithm.*

Explanations to the figure:



Analog smoke detector 3304. The week average sensor value is "10", i.e. the smouldering level is adjusted to "24", the pre-warning level to "32" and the fire alarm level to "40".

When a smouldering fire starts, the sensor values and the decision values will increase slowly upwards from "10".

1. The decision value has here reached the smouldering level. A 7 minutes timer is started.
2. After the 7 minutes the decision value is still over the smouldering level. The pre-warning level and the fire alarm level are lowered. A 90 minutes timer is started.
3. The decision value has here reached the pre-warning level and pre-warning is activated.
4. After the 90 minutes the decision value is still over the pre-warning level but has not reached the fire alarm level. The pre-warning level and the fire alarm level are lowered again.
5. The decision value has here reached the fire alarm level and fire alarm is activated.
6. The decision value has here reached the original fire alarm level. The fire alarm would have been activated approx. 90 minutes later than with the smouldering algorithm!

## 16.5 Performance factor

To find out how the environment is, where an analog smoke detector 3304 or 3316 is mounted, the **performance factor** can be studied.

The performance factor is calculated for each detector individually.

Each sensor value is compared with the week average sensor value. The absolute difference is saved and each twenty-four hour (at midnight) is an "average value" calculated, i.e. the performance factor.

If the detector is mounted in a very "stable" environment, the performance factor will be low (min. 0 %/m).

If the detector is mounted in a very "unstable" environment, the performance factor will be high (max. 2.55 %/m).

An "unstable" environment can cause nuisance alarms (unnecessary alarms). Perhaps should another type of detector be used, another alarm algorithm be used or other actions be taken, e.g. alert annunciation or two-address dependence.

The performance factor is shown in menu H4/U5 together with the min. and max. sensor values. All three values should be studied together. (E.g. one or two high sensor values will not result in a high performance factor.)

## 16.6 Algorithms for analog heat detectors

The following is valid only for the analog heat detector types **33xx in NORMAL mode** (= AHD3308 / AMD3316 in Win512).

The detectors conforms to a class (see EN54-5:2000, clause 4.2) according to the requirements of the tests specified in EN54-5:2000, clause 5.

Each analog heat detector can have two alarm algorithms programmed (via Win512). One **alarm algorithm** that is normally used and one **alternative alarm algorithm** that is used when a time channel (internal or external) is activated. E.g. class A1 can be used in the night-time and class B can be used in the daytime (the alternative alarm algorithm is used to reduce nuisance alarms during working hours). The actual algorithm can be read in menu H4/U5.

When the c.i.e. has picked up a sensor value above the **fire alarm** level for a detector, the next two values from that detector also have to be above the fire alarm level to activate fire alarm in the c.i.e. (This results in an approx. 5 seconds alarm delay).

The same is valid for **pre-warning** only that it is a lower level than for fire alarm. (If pre-warning shall be presented or not, is selected in the "Control Unit" dialog box in Win512).

The same is valid for **heavy heat alarm** only that it is a higher level than for fire alarm. Heavy heat alarm will always be printed out and saved in the event log. (No other heavy heat alarm presentation).

The fire alarm, pre-warning and heavy heat alarm level respectively can, for the whole system, be set in Win512, see chapter "Alarm algorithms", page 112.

See EBL512 Operating instructions for more information.

### 16.6.1 Class A1 algorithm

Conforms to Class **A1**.

Typical / max. application temperature 25 / 50° C.

Max. / min. static response temperature 54 / 65° C.

The algorithm is as follows:

For a rate-of-rise  $\leq 4^\circ$  C per minute:

Fire alarm level is 56° C.

Pre-warning level is 46° C.

Heavy heat alarm level is 90° C.

Rate-of-rise  $> 4^\circ$  C per minute:

Fire alarm level is 46° C.

Pre-warning level is 36° C.

Heavy heat alarm level is 90° C.

The "Class A1 algorithm" will detect a fast temperature rise (rate-of-rise  $> 4^\circ$  C per minute) some minutes earlier than the "Class A2 algorithm".

### 16.6.2 **Class A2 S algorithm**

Conforms to Class **A2 S**.

Typical / max. application temperature 25 / 50° C.

Max. / min. static response temperature 54 / 70° C.

The algorithm is as follows:

Fire alarm level is 60° C).

Pre-warning level is 50° C.

Heavy heat alarm level is 90° C.

### 16.6.3 **Class B S algorithm**

Conforms to Class **B S**.

Typical / max. application temperature 40 / 50° C.

Max. / min. static response temperature 69 / 85° C.

The algorithm is as follows:

Fire alarm level is 74° C.

Pre-warning level is 64° C.

Heavy heat alarm level is 90° C.

The "Class B S algorithm" can be used when the application temperature is "high" (compare with the "Class A1 an A2 S algorithms).

## 16.7 **Algorithm setting via menu H4/U5**

**NOTE! Algorithm setting via menu H4/U5 is only valid for the "British Standard Marine Application" convention.**

The alarm algorithm can be set via menu H4/U5 for the following detectors:

**3304** in NORMAL mode

**3308 / 3309** in NORMAL mode

**3316** in NORMAL mode (the "Decision algorithm" is not possible to use)

No alternative algorithm can be used.

No values (offset, level, etc.) can be set via menu H4/U5 (i.e. these values have to be set via Win512).

The "Short name" (set in Win512) can be  $\leq 5$  characters.

If an algorithm is set via menu H4/U5, the site specific data (SSD) in the c.i.e. is not equal to the SSD file downloaded from Win512, i.e. a back up is required to update the SSD file (xxxxxx.512).

If an algorithm is set via menu H4/U5, the information in menu H5/A4 will be changed from "Downloaded: xxxx" to "Modified by CU: xxxx".

See also the EBL512 Operating Instructions for version 2.1.x.

## 16.8 Self verification

The analog detectors 33xx (in NORMAL mode) have a built-in self verification function. The detector's HW is always supervised by the detector's SW and CPU. Every minute, each detector will receive a question from the c.i.e. If the self verification function has detected any fault it will be reported back to the c.i.e. A fault will be activated in the system and the following fault message will be shown:

FAULT: Sensor techn. no. nnnnnn

## 16.9 Minimum / Maximum sensor values

To find out how the environment is, where an analog detector 33xx (in NORMAL mode) is mounted, the **minimum and maximum sensor values** can be studied. The sensor values are continuously picked up and evaluated by the control unit (c.i.e.) for each detector individually. Every value is checked if it is a new minimum or maximum value for that detector. At midnight every day a memory will be updated and the new minimum and maximum sensor values can be read in menu H4/U5<sup>99</sup>.

For analog smoke detectors the minimum and maximum sensor values are shown as XX.X % (obscuration) per meter. (The values are not shown for analog smoke detectors type 23xx).

For analog heat detectors the values are shown as XX°C.

## 16.10 2-zone / address dependence (co-incident alarm)

In some premises 2-zone / address dependent fire alarm ("Two unit dependent" in Win512) can be used to avoid unwanted false alarms (nuisance alarms).

### 16.10.1 2-zone dependence

Each zone in the system can be programmed to a "Two zone dependent" fire alarm activation. The zone has to belong to one of nine "Two zone dependent groups" (1-9).<sup>100</sup>

Function: Two or more zones in the same group have to be in "fire alarm state" at the same time to activate fire alarm in the control unit. When only one of the zones is in "fire alarm state" it is indicated in the control unit (c.i.e.) as follows:

- LEDs "Fire" (blinking).
- the buzzer sounds like for pre-warning.
- In the alphanumeric display is the following text shown:  
Co-incident alarm zone ZZZ
- The zone no. is also shown in menu H4/U4.

---

<sup>99</sup> I.e. the min. / max. sensor values shown, are from the previous day.

<sup>100</sup> Default for all zones is group no. 0 = **no** Two zone dependence.

Programmable outputs can be activated by trigger condition "Two Zone Dependency Fire Alarm" but no other outputs will be activated.

## 16.10.2 2-address dependence

Each analog or addressable detector, Addressable zone interface (2226 / 2335) input, addressable multi purpose I/O unit (3361) monitored input (Z) and 8 zones expansion board (1580) can be programmed to a 2-address dependent fire alarm activation. (Heat detectors should not and manual call points must not be 2-unit dependent).

Function: Two or more units in the same zone have to be in "fire alarm state" at the same time to activate fire alarm in the control unit. When only one unit is in "fire alarm state" it is indicated in the control unit (c.i.e.) as follows:

- LEDs "Fire" (blinking).
- the buzzer sounds like for pre-warning.
- In the alphanumeric display is the following text shown:  
Co-incident alarm detector ZZZ/AA
- The zone no. and address is also shown in menu H4/U4.

Programmable outputs can be activated by trigger condition "Two Detector Dependency Fire Alarm" but no other outputs will be activated.

## 16.11 Delayed alarm

In some premises delayed fire alarm activation can be used to avoid unwanted false alarms (nuisance alarms). Note, that this function is a violation to the EN54-2 standard.

Each analog or addressable detector, each Addressable zone interface (2226 / 2335) input, each addressable multi purpose I/O unit (3361) monitored input (Z) and 8 zones expansion board (1580) input in the system can be programmed (in Win512) to delayed fire alarm activation. (Heat detectors should not and manual call points must not have delayed fire alarm activation). The delay time can be set to 1-127 seconds.<sup>101</sup>

Function for an analog or addressable smoke detector: An alarm point in "fire alarm state" has to be in this state all the delay time, in order to activate fire alarm in the control unit. If an alarm point goes back to "normal state" during the delay time, the delay time will be reset and start again if/when the alarm point comes in "fire alarm state" again.

Function for an addressable zone interface (2226 / 2335) input, each addressable multi purpose I/O unit (3361) monitored input (Z) and 8 zones expansion board (1580) input: A zone in "fire alarm state" will be recorded in the control unit but fire alarm will not be activated. When the delay time is out the zone will be reset and if it still is in "fire alarm state", fire alarm will be activated in the control unit.

---

<sup>101</sup> Default is 0 seconds and a normal delay time is 30 seconds.

## 16.12 Alert annunciation

In some installations alert annunciation can be used to avoid unwanted false alarms (nuisance alarms) to the fire brigade. Trained personnel, on site, are required to locate the fire (the room) and take the correct measures (depending on if there is a fire or not).

Normally analog or addressable smoke detectors and zones with smoke detectors only, come in question to be programmed (in Win512) for alert annunciation. Heat detectors and manual call points should normally not come in question for alert annunciation. A manual call point can only activate the alert annunciation function if there are no other fire alarms activated (i.e. the second fire alarm will turn the alert annunciation function OFF).

Alert annunciation is normally ON during the daytime working hours only. The time channels 1-4 or the external time channels 5-12 can be used to turn ON and OFF the alert annunciation function.

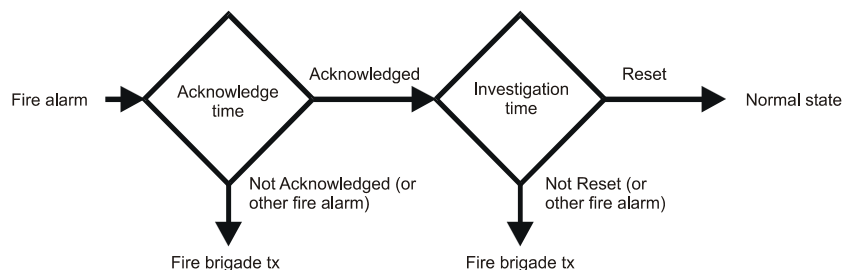

*Figure 18. Alert annunciation principle.*

**Function:** Indications, print-outs, actions, etc. as for a normal fire alarm **except output(s) for routing equipment (fire brigade tx), which will not be activated directly.** Also indicated by the LED "Fire brigade tx delay".

The fire alarm has to be acknowledged within an acknowledge time and the fire alarm has to be reset within an investigation time, else will the output(s) for routing equipment (fire brigade tx) be activated.

During the acknowledge and investigation times:

- If another fire alarm is activated by a detector / zone not programmed for alert annunciation or if fire alarm is activated by a manual call point, the output(s) for routing equipment (fire brigade tx) will be activated.
- If another fire alarm is activated by a detector / zone which is programmed for alert annunciation, it is depending on if "Multiple alarms allowed within same zone" is set<sup>102</sup> in Win512 (for the system). The number of zones<sup>103</sup> allowed activating fire alarm, before the output(s) for routing equipment (fire brigade tx) will be activated, is also set in Win512 (for the system).

<sup>102</sup> Default the Check box is marked = Multiple alarms allowed within same zone.

<sup>103</sup> Default is one zone. Up to four zones can be set.

Acknowledge and Reset is done on the Display unit 2235. Programmable output ("Alert Announcement Activated" for indication and programmable inputs ("Alert Announcement Acknowledge" and "Alert Announcement Reset") can also be used.

The Acknowledge time can be set to 5-495 seconds.<sup>104</sup>

The Investigation time can be set to 1-40 minutes.<sup>105</sup>

NOTE! According to EN54-2, the total delay of fire alarm routing equipment must not exceed 10 minutes (i.e. Acknowledge time + Investigation time  $\leq$  10 min.).

## 16.13 Disable alarm points and outputs

Temporary disablements are made via the menu H2 sub menus. For more information see EBL512 Operating Instructions, chapter "Disable or re-enable (H2)".

Regular disablements are made via time channels, see chapter "Time channels", page 110.

Disabled alarm points and outputs are indicated by LED "Disablements" and listed in menu H4/U1.

**Enhanced Disablement** (Default) = Fire alarm, pre-warning and fault signal can not be activated by the disabled alarm point/zone. If only fire alarm and pre-warning shall be disabled, Enhanced Disablement shall be re-enabled, see chapter "Miscellaneous", page 109.

### 16.13.1 Disable zone

A whole zone (all addresses within a zone) can be disabled via menu H2/B1. Re-enable via menu H2/B4.

### 16.13.2 Disable zone / address

Individual alarm points can be disabled via menu H2/B2. Re-enable via menu H2/B5.

Time channels can be used to disable and re-enable automatically.

### 16.13.3 Disable control output

Individual control outputs can be disabled via menu H2/B3. Re-enable via menu H2/B6. Disabled output will stay in (or return to) the normal condition for the output respectively.

## 16.14 Disable interlocking output

Disable via menu H9/C4. Re-enable via menu H9/C5. For more information see chapter "Disable interlocking output (H9/C4)", page 80.

---

<sup>104</sup> (1-99) x 5 = 5-495 seconds (8 minutes and 15 seconds).

<sup>105</sup> (1-40) x 1 = 1-40 minutes.

## 16.15 Disable outputs for routing equipment

Disable and Re-enable via menu H8/S1. For more information see EBL512 Operating Instructions.

## 16.16 Disconnect / Re-connect loop

Disconnect via menu H8/S2 and Re-connect via menu H8/S3:

0. COM loops
1. BS4 loops
2. 8 zones expansion board 1580 (zone line input)
3. Addressable zone interface 2226 / 2335 / 3361 (zone line input)

For more information see EBL512 Operating Instructions.

## 16.17 External time channels 5-12

External time channels can be used to:

- disable and re-enable alarm points
- set alert annunciation ON / OFF
- activate programmable control outputs
- set alternative alarm algorithm for analog detector types 33xx ON / OFF

External time channels 5-12 are for the whole system. A programmable input ("Time Channel N") is used for each time channel. The input is controlled by some external equipment, e.g. another time system, a key switch, a timer, etc. with a normally open contact (normally low) or a normally closed contact (normally high). When the input is "activated" the time channel is ON.

NOTE! Do not use more than one input per time channel. (This is checked in the "Validity check" in Win512).

## 16.18 Test mode

Up to four zones can be set in Test mode at the same time.<sup>106</sup> Alarm points / zones can be tested during the Monthly test (via menu H1) or separately (via menu H7). For more information see EBL512 Operating Instructions. The LED "Test mode" indicates one or more zones in Test mode. Zones in Test mode are also simultaneously shown in the c.i.e. alphanumeric display. Disablements, faults and fire alarms have higher priority, i.e. the presentation of zones in Test mode will be suppressed during such a condition.

## 16.19 Calibration of supervised outputs

In order to get the best supervision possible, the supervised (monitored) outputs have to be calibrated after the installation. This is done via a menu (H5/A1) in the c.i.e.

---

<sup>106</sup> In DBI (Danish) convention only one zone.



## 16.20 Service signal

All smoke detectors get contaminated no matter what environment it is mounted in. In some environments it goes faster than in others.

Conventional smoke detector:<sup>107</sup> The sensitivity will increase in some environments and decrease in others. This can result in unwanted false alarms (nuisance alarms) or no alarms at all.

Analog smoke detector:<sup>108</sup> The detector is supervised at all times and when required, a service signal will be activated.

Service signal levels for the different types:

3304, 3316:	- / 18	(on a scale 1-151 resp. 1-127)
2300, 2304:	5 / 30	(on a scale 0-63)
2200, 2202:	10 / 60	(on a scale 0-127)
Autronica:	5 / 100	(on a scale 0-240)

For more information, see EBL512 Operating Instructions chapter "Sensors activating Service signal (H4/U6)" and "Acknowledge Service signal (H8/S4)".

## 16.21 Analog smoke detector

An analog smoke detector is like a "sensor". It detects its environment at all times. Detected analog values are converted to digital values, "sensor values", which are continuously picked up and evaluated by the control unit (c.i.e.) for each detector individually. In Figure 19 the (analog) sensor values are represented by the graph "Working level".

Analog smoke detectors 23xx (and 33xx in 2312 mode<sup>109</sup>):

Each hour, one sensor value is stored (in the c.i.e.) and each week a new "week average sensor value" is calculated<sup>110</sup>. In Figure 19 the (digital) week average sensor values are represented by the graph "Week average". NOTE! The graph can be adjusted up or downwards!

Each type of analog smoke detector has a specific default sensor value ("Working level" & "Week average" at "Time 0"). A fire alarm offset (value) is added to get the detector's fire alarm level. The fire alarm level will be adjusted in relation to each new week average sensor

---

<sup>107</sup> A conventional smoke detector has a fixed fire alarm level.

<sup>108</sup> An analog smoke detector adapts its fire alarm level in relation to how contaminated it is, see chapt. "Analog smoke detector", page 95.

<sup>109</sup> Regarding analog smoke detectors 33xx in NORMAL mode, see chapter "Alarm algorithms for smoke detectors / Detection levels / Offsets", page 82.

<sup>110</sup> The values stored during the week are used to calculate a new week average sensor value. The very first week average sensor value will be calculated within 2 minutes after SSD download & restart. (During this "2 min. period" no fire alarm can be activated.)

value, i.e. the detector's fire alarm sensitivity is constant. The fire alarm level is in Figure 19 represented by the graph "Fire alarm level". Service signal will be given for a high and a low level, see "Service level" in Figure 19.

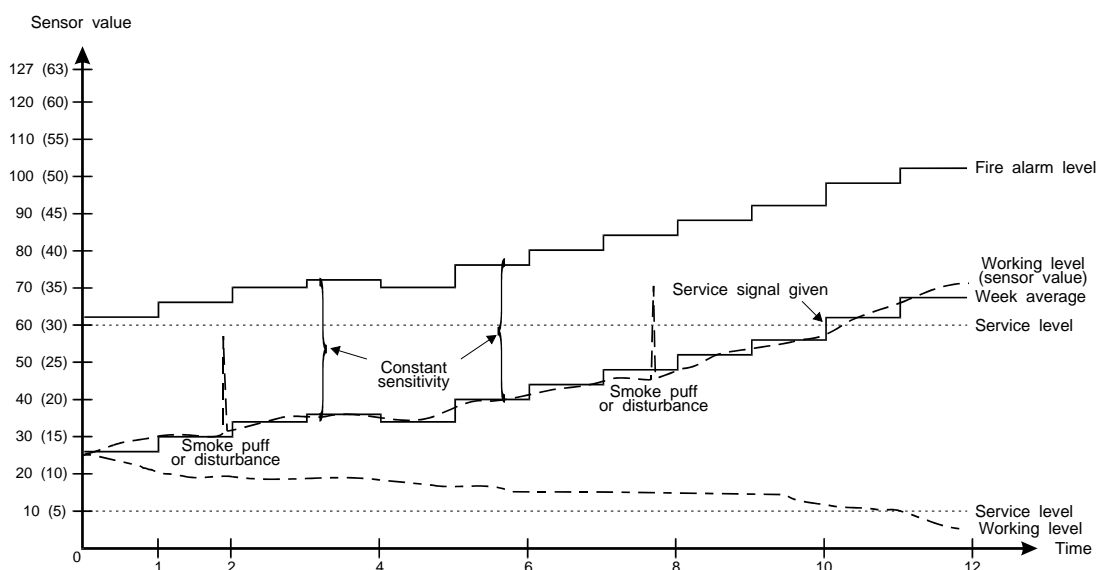

**Figure 19. Working principle for an analog smoke detector (sensor), type 23xx (and 33xx in 2312 mode).**

Via Win512 and a PC connected to a control unit, you can get "Sensor Information", for all analog detectors on a COM loop or an individual detector, as follows:

Technical no. | Zone-Address | Min. | Max. | Momentary | Weekly | Performance factor.

For smoke detectors the obscuration in % per meter and for heat detectors in °C. For some type of detectors, not all information can be shown. For an individual detector you can get the information continuously. See also Win512 help.

## 16.22 Fault signal (fault condition)

Fault signal, fault messages, fault acknowledge, etc. are described in EBL512 Operating Instructions, chapter "Fault".

Programmable inputs can be used to activate fault signal in the EBL512 control unit, see chapter "Programmable inputs", page 57.

## 16.23 User definable text messages

When a fire alarm is activated, the presentation number will be shown on the first row in the control unit's and the ext. FBP's alphanumeric display. On the second row will be shown a user definable text message, if programmed.<sup>111</sup> The user definable text message will also

<sup>111</sup> See also chapter "Limitations", page 131.

be printed out when a printer is available.

When only one fire alarm is activated, both zone number and address will be shown and an individual user definable text message (if programmed) will be shown for that alarm point.

When more fire alarms are activated, only the zone numbers will be shown and an individual user definable text message (if programmed) will be shown for each zone.

See also EBL512 Operating Instructions, chapter "Fire alarm".

User definable text messages can also be shown in Display units connected on the COM loops.

The texts<sup>112</sup>, up to 40 alphanumeric characters, are created and downloaded via Win512. (An "older" DOS based PC program NEWTEXT can also be used, see chapter "Display units (addressable)", page 46.)

Each addressable alarm point can have one user definable text message displayed in the control units and ext. FBPs and one user definable text message displayed in each Display unit on the COM loops. See also Win512 help.

### 16.23.1 Creating the user definable text messages via Win512

For more information, see also Win512 help.

In the "Texts" menu select "Edit" and a "Win512 Texts" window will be displayed. This is a table ("Excel") with three columns, **Tech No**, **Zone-Addr** and **Text**.

Some examples are to be found in the following table. Explanations follows the table.

	<b>Tech No</b>	<b>Zone-Addr</b>	<b>Text</b>
1a		001-01	Fire in Laboratory 2 Floor
1b		002-00	Fire in Entrance
2	003123	001-01	Fire in Laboratory
3	C00	default	FIRE ALARM
4	003123	default	FIRE ALARM Zone: # Addr: #
5	inter	001-01	Interlocking combination Area 001 - Point 01

*Figure 20. Examples of user definable text messages. (NOTE! In the Display units 2235 / 2236, there are two rows à 20 characters).*

<sup>112</sup> Up to 194 texts if the 8K EEPROM is used and up to 816 texts if the 32K EEPROM is used in the display unit.

### **Tech No** column

1. The **Tech No** column shall not be filled in when creating a text for a specific addressable alarm point (1a) or a whole zone (1b), to be shown in the Control unit(s) / ext. FBP(s).
2. The **Tech No** column shall be filled in with the Display unit's technical number (e.g. 003123) when creating a text for a specific addressable alarm point, to be shown in this Display unit.
3. The **Tech No** column shall be filled in with the Control unit's technical number (e.g. C00) when creating a "default" text (see below), to be shown in the Control unit / ext. FBP(s).
4. The **Tech No** column shall be filled in with the Display unit's technical number (e.g. 003123) when creating a "default" text (see below), to be shown in this Display unit.
5. The **Tech No** column shall be filled in with the word "inter" when creating a text for an Interlocking combination.

### **Zone-Addr** column

- 1a. The **Zone-Addr** column shall be filled in with the presentation number (Zone-Addr) when creating a text for a specific addressable alarm point.
- 1b. The **Zone-Addr** column shall be filled in with the presentation number (Zone-Addr) when creating a text for a specific zone, i.e. the address "00" shall be written when only the zone number is to be shown.
2. The **Zone-Addr** column shall be filled in when creating a text for a specific addressable alarm point, to be shown in a Display unit, i.e. the presentation number (Zone-Addr) shall be written here.
3. The **Zone-Addr** column shall be filled in with the word "default" when creating a "default" text (see below), to be shown in the Control unit / ext. FBP(s).
4. The **Zone-Addr** column shall be filled in with the word "default" when creating a "default" text (see below), to be shown in this Display unit.
5. The **Zone-Addr** column shall be filled in with the presentation number (Area-Point) when creating a text for an Interlocking combination.

### **Text** column

When creating a text, remember that the Display unit's alphanumeric display has two rows à 20 characters (see Figure 20.).

**A tip:** Click "Preview" and each text will be shown (in the different types of alphanumeric displays) at the same time as it is typed.

In a "default" text (see below), the first parameter symbol # will be replaced with the zone number (up to three digits) and the second parameter symbol # will be replaced with the address number (up to two digits) when presented in the alphanumeric display.

NOTE! When programming a specific addressable alarm point (e.g. an analog smoke detector), there is a "Text" field in the dialog box. The user definable text message can be written directly in this field. It will automatically be added, together with the presentation number, in the table / list described above.

In a large system, i.e. many texts, a "Filter" can be used to show only desired data. The columns, **Tech No**, **Zone-Addr** and **Text** can be used with "equal to" (==), "less than" (<), "more than" (>), "not equal to" (!=) and "a sub string" (€).

Three rows can be used with an "OR operator" (checkbox "And" not marked) or an "AND operator".

E.g. show only technical numbers less than 000100: **Technical number < 000100**. Mark the checkbox "Filter active" and click "OK".

### Default text

1. Global function (default):

A "default" text can be created for each Control unit and each Display unit respectively. All addressable alarm points that have no individual text, will be presented with the "default" text.

In the Display units, a zone number parameter (#) and an address number parameter (#) can be added. (In the Control units / ext. FBPs, the Zone-Address is automatically presented).

2. Local function (set in the "Downloading Texts To Display Unit" dialog box):

Local function is only valid for a Display unit. All addressable alarm points that have no individual text, will **not** be presented in the Display unit.

## 16.23.2

### Downloading texts to Display Unit

A PC has to be connected to the Display unit.<sup>113</sup> Press the "Display unit reset" button. The following text will be shown in the display:

Programming..... Version: X.x
----------------------------------

The Display unit is now prepared for downloading.

Start up Win512 and select the file to be used. In the tree view, select a Display unit icon<sup>114</sup> and click on the right mouse button. In the "Display unit" (Alphanumeric display) pop-up menu, select "Download Texts" and a "Downloading texts To Display Unit" dialog box will be displayed.

---

<sup>113</sup> A "PC communication interface" 4001 is plugged in the Display unit "K1" connector (6-way MODULAR) and in the PC COM port.

<sup>114</sup> To add a Display unit, select a COM loop icon, click on the right mouse button. In the Loop X pop-up menu, select "Add Loop Unit" and an "AD, Alphanumeric Display" (Display unit) dialog box will be displayed.

In the "Status" field, an information text will be shown if a 32K EEPROM is required in the Display unit.

Select "COM Port" and "Display Type". There is also a check box for Local function (see "Default text" above).

Click "Start". In the "Status" field will now be shown:  
Downloading . . . . . and after a few seconds:  
Download complete.

Click "Cancel" or "☒". The Display unit can now be set in "Test mode" or "Demo mode" to check the downloaded texts.

### Test mode

- Plug the "PC communication interface" 4001 in the Display unit "K1" connector (6-way MODULAR).
- Set (short circuit) jumper BY1.
- Press the "Display unit reset" button. The following text will be shown in the display:

Test mode Version: X.x
---------------------------

- The "fire alarm RESET" button is used to scroll between the texts. (First will the zone/address be shown and then the text.)
- Quit the "Test mode" by removing the jumper BY1 and the plug and press the "Display unit reset" button (if required).

### Demo mode

- Set (short circuit) jumper BY1. (No plug in the "K1" connector.)
- Press the "Display unit reset" button. The following text will be shown in the display:

Demo mode Version: X.x
---------------------------

- The texts will now be automatically shown, one by one (preceded by a beep).
- Quit the "Demo mode" by removing the jumper BY1 and press the "Display unit reset" button (if required).

### Display Unit Properties

In the Win512 "Display unit" (Alphanumeric display) pop-up menu, select "Loop Unit Properties" and an "AD, Alphanumeric Display" (Display unit) dialog box will be displayed.

The Display unit's Logical Name and Technical number is shown. The "Number of texts" created for that Display unit is displayed and an information text regarding the Display unit's EEPROM is shown: "8K (max. 196 texts) or a 32K (max. 810 texts)".<sup>115</sup>

---

<sup>115</sup> The 32K EEPROM (28C256) require the jumper BY2 to be set (short circuit) in the Display unit.

## 16.24 Real time clock (RTC)

Each control unit has an RTC. It is used for (date) and time presentation for fire alarms, faults, event logging and the time channels 1-4.

In a system (two or more control units in a TLON network) all control units are synchronised.

## 16.25 Printer disable function

NOTE! Only valid for Chinese convention.

Press the keys "Paper feed" and "C" at the same time to disable the printer. The printer will now stay disabled until the keys "Paper feed" and "C" are pressed again.

Printer disabled is indicated by LED "Printer disabled".

There is no memory, i.e. the not printed information is lost and can not be printed out "later".

## 16.26 Loss of main power source

Fault signal delay time for "Loss of main power source" can be set (in Win512) to 1 – 300 minutes. Note, that a delay time > 30 minutes is a violation to the EN54-2 standard.

## 16.27 Win512 Tools menu

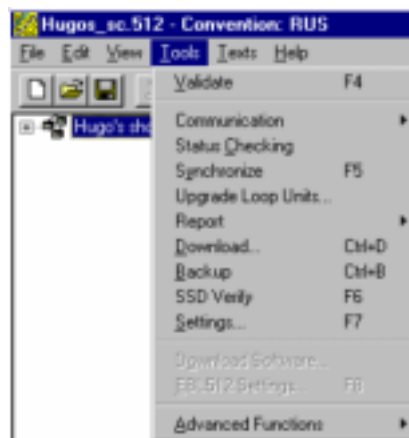

*Figure 21 . Win512 "Tools" menu. Some commands can be disabled, see Win512 help.*

The Win512 "Tools" menu is used, when the PC is to be connected to an EBL512 control unit and for download / backup.

**Validate:** The SSD is validated before downloaded to an EBL512.

**Communication:** Log on / Log off to the EBL512.

**Status Checking:** (When connected and logged on to an EBL512.)  
Fault status indication in Win512.

**Synchronize:** (When connected and logged on to an EBL512.)  
Synchronization of control units (same data in all control units).

**Upgrade Loop Units:** To upgrade 33xx detectors to NORMAL mode (one at a time or all on one COM loop at the same time).

**Report:** Prints out a "Zone-Address → Output" list or a "Time channel → Zone-Address" list.

**Download:** (When connected and logged on to an EBL512.) For downloading of SSD to one or more EBL512 units.

**Backup:** (When connected and logged on to an EBL512.) For backup of SSD from all the EBL512 units.

**SSD verify:** (When connected and logged on to an EBL512.) The Win512 SSD is compared to the EBL512 SSD.

**Settings:** Some settings (e.g. for communication), convention, etc.

**Download software:** (When connected, not logged on to an EBL512.) For download of SW (+ SW text file) to the EBL512 unit.

**EBL512 settings:** (When connected, not logged on to an EBL512.) Read or download EBL512 settings to an EBL512 unit. The existing EBL512 SSD can be cleared (erased).

**Advanced functions:** No "Level" selected = Alarm algorithm parameters can not be changed. "Level 1" selected = Alarm algorithm parameters can be changed, but not for fire alarm. "Level 2" selected (a password is required) = Alarm algorithm parameters can be changed, also for fire alarm. Convention is possible to change (in "Settings").



## 17 Control unit properties (settings)

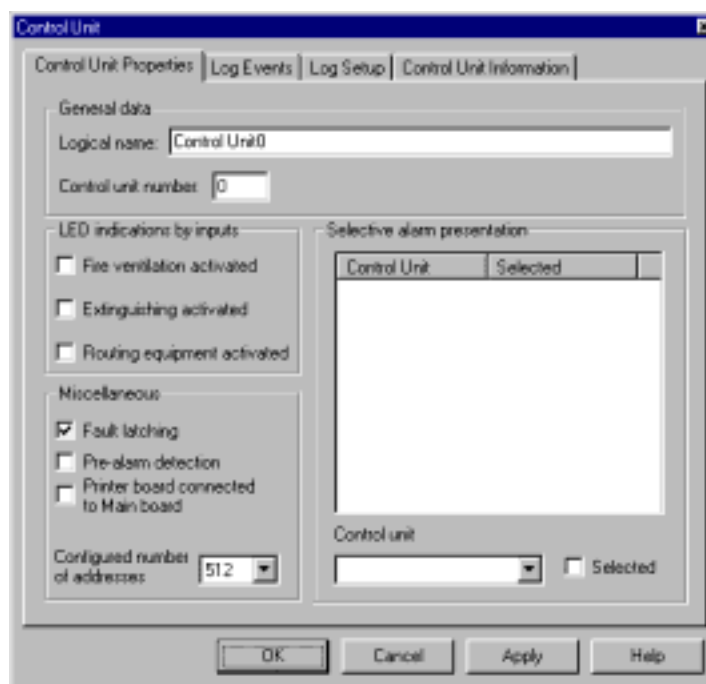

Figure 22. Win512 "Control unit" dialog box.

NOTE! Default settings in Win512 are shown but may vary depending on convention.

### 17.1 Control unit data

#### 17.1.1 General data

**Logical name:** Normally not changed (but can be changed when necessary).

**Control unit number:** A stand-alone control unit has no. 00. In a system the control units are numbered 00 to 29.

#### 17.1.2 LED indications by inputs

Normally the LED indicators listed below will be lit when a corresponding output is activated<sup>116</sup>. When selected, the LED will be turned on when a programmable input is activated instead, e.g. a feedback from a fire brigade tx output can activate a programmable input to turn on the LED "Fire brigade tx".

- Fire ventilation activated:** LED "Ventilation"
- Extinguishing activated:** LED "Extinguishing"
- Routing equipment activated:** LED "Fire brigade tx"

---

<sup>116</sup> Type of output = Extinguishing, Fire ventilation and Routing equipment respectively.

### 17.1.3 Miscellaneous

- Fault latching** (default): all faults, also corrected faults, have to be acknowledged. No fault latching = not corrected faults have to be acknowledged but corrected faults have not to be acknowledged.
- Pre-warning detection**: The pre-warning detection in a control unit is not enabled until the check box is marked **but** pre-warnings activated in other control units in the system will always be presented in all control units and all programmable outputs in the system, with trigger condition pre-warning, will be activated (if not disabled).
- Printer board connected to Main board**: This check box shall be marked when the c.i.e. has a built-in printer (i.e. EBL512 type number 1549).

**Configured number of addresses**: 128, 256 or 512. Shall be set to the same as in EBL512 settings ("Max. loop units"). This setting is used when programming alarm points in Win512. When doing a validation check you will get a message if too many alarm points have been programmed in relation to the settings. (This check is automatically performed when downloading the SSD to the c.i.e.)

### 17.1.4 Selective presentation of alarms

In a system (i.e. two or more control units in a TLON network) it is possible to choose which control units' fire alarms<sup>117</sup> that shall be presented in each control unit.

Default = All fire alarms will be presented in all control units. In each "Control unit" dialog box, the control units that shall not be presented in that control unit have to be **de-selected**.

**Example**: A system with four control units (C.U. 0, 1, 2 and 3). In C.U. 0 shall only fire alarms from C.U. no. 0 to be presented and in C.U. 1, 2 and 3 shall all fire alarms to be presented.

How to de-select a control unit: Select a control unit in the "Control unit" drop down list box (e.g. 1) and empty the "Selected" check box (on the right side). Click the "Apply" button and Selected = 1 changes to Selected = 0.

This has to be done for control units 2 and 3 also.

"Control unit" dialog box for control unit 0. Control units 1,2 and 3 are de-selected:

---

<sup>117</sup> Activated by alarm points, etc. connected to a control unit.

Control unit	Selected
0	1
1	0
2	0
3	0

"Control unit" dialog box for control unit 1, 2 and 3 respectively. No control unit is de-selected:

Control unit	Selected
0	1
1	1
2	1
3	1

## 17.2 Log events

The general event log can be shown / printed out via menu H4/U7 or via Win512. The following events are all selected by default.

- Alarm (All fire alarms)
- Reset alarm (All fire alarm resets)
- Encapsulations (All "Zone/Detector not reset")
- All disconnected (All disablements except those via time channels)
- Re-enablements (All re-enablements except those via time channels)
- Fault (All faults)
- Acknowledge fault (All acknowledged faults)
- Fault serviced (All corrected faults)
- Service signal (All analog smoke detectors having activated service signal)
- Acknowledge service signal (All service signal acknowledges)
- Test mode activation and de-activation (Test mode ON / OFF)
- Programming misc. (Actions done via menu H5)
- Open/Closed door (All opened / closed doors)
- Activated outputs (All activated outputs)
- Downloading SSD (Download of site specific data via Win512)
- Interlocking (Activated interlocking output / input)

## 17.3 Log setup

All event log setups are made in Win512. Default setup is normally used.

NOTE!

A fixed memory area is dedicated for all logs. Depending on type of log(s), how many and which events that are to be logged, etc. you might get a "Limits exceeded" warning in Win512.

Date & Time are stored together with every event.

For more information, see Win512 help. Regarding circular logging:

- Circular logging:** The log re-starts when it is "full". The first events will be overwritten, i.e. a circular log shows the xx latest events.
- Circular logging:** Not circular logging = straight logging = the log stops when it is full and has to be erased before the logging can start again, i.e. a straight log shows the xx earliest events.

### 17.3.1 General event log

What will be logged is selected in the "Event Logs" tab. The log can be shown via EBL512 (menu H4/U7) or via Win512 (the Control unit pop-up menu | Show General Event Log).

**Number of recorded logs:** Default is 150 events. 0-214 is possible.

- Circular logging**

### 17.3.2 Sensor log

Only analog smoke detectors (sensors) having reached the pre-warning level or the sensor value zero will be logged. This information (techn. no. and sensor value) is useful when commissioning an installation or is used by service engineer for troubleshooting.

NOTE! The Sensor log can be shown in a future Win512 version only.

**Number of recorded logs:** Default is 20 events. 0-20 is possible.

**From technical number:** Interval start number. Normally (default) number 000000.

**To technical number:** Interval stop number. Normally (default) number 293127 (i.e. the highest possible technical number for a COM loop unit in a system).

- Circular logging**
- Min/max log:** Each analog detectors' min. and max. sensor value respectively will be logged if the checkbox is marked.

NOTE! The Min/max log can be shown in a future Win512 version only.

### **17.3.3 Communication error log**

Communication error occurring on the COM loops will be logged together with the technical number.

NOTE! The Communication error log can be shown in a future Win512 version only.

**Number of recorded logs:** Default is 15 events. 0-15 is possible.

**Circular logging**

## **17.4 Control unit information**

In this tab you can **read** the following information:

**Logical name**

**Control unit** (number)

**No. of expansion cards**

**No. of addresses**

**No. of alarm points (detectors in conventional zones excluded)**

**No. of alarm points (detectors in conventional zones included)**

**No. of zones**

When a name / number / unit is changed, added or removed, this information will be updated.

## 18 System properties (settings)

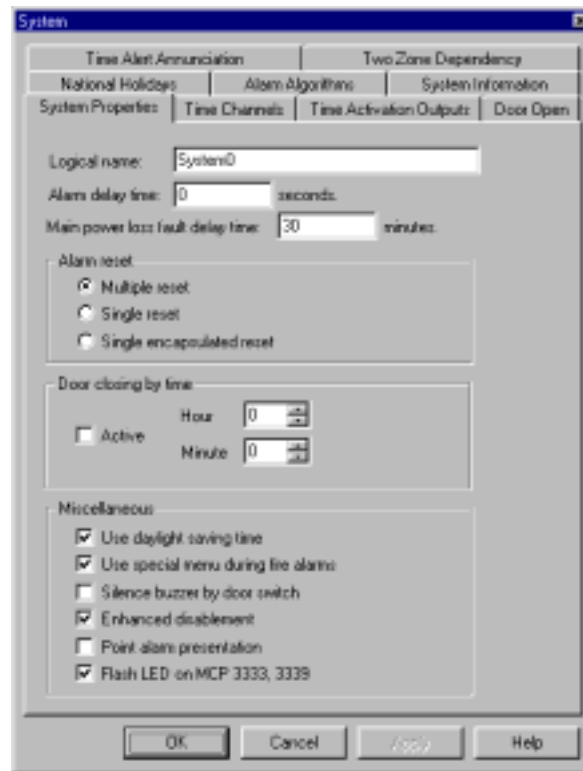

Figure 23. Win512 "System" dialog box.

NOTE! Default settings in Win512 are shown but may vary depending on convention.

### 18.1 System data

#### 18.1.1 Logical name

Normally not changed but each system can have a unique name.

#### 18.1.2 Alarm delay time

The fire alarm delay time is set here for the detectors with this option selected via Win512. Default is "0" and up to 127 seconds can be set. Note! This delay starts when the alarm normally should have been activated, i.e. it will be added to all other delay times (e.g. after an L-/N-/H-35 algorithm).

#### 18.1.3 Main power loss fault delay time

A fault will be activated 30 minutes (default) after loss of mains (230 V AC). 0 – 300 minutes can be set.

#### 18.1.4 Alarm reset

One of the following alternatives can / shall be selected.

- Ⓒ **Multiple reset** (default): All activated fire alarms in the system will be reset simultaneously by pressing the "Reset" button.

- **Single reset:** One activated fire alarm in the system, shown in the control unit's alphanumeric display on the first row to the left, will be reset by pressing the "Reset" button, i.e. all activated fire alarms have to be reset one by one. This function is a violation to the EN54-2 standard.
- **Single encapsulated reset:** Encapsulation function. This function is a violation to the EN54-2 standard.

Encapsulation function: If an alarm point / zone is reset while still in alarm state (e.g. smoke in a smoke detector or an activated manual call point) this unit will be encapsulated until it is re-enabled via menu H2/B7. Before it is re-enabled it can not activate fire alarm again.

LED "Disablements" is blinking to indicate one or more encapsulated zones / detectors.

### 18.1.5 Door closing by time

- **Active:** If all fire doors shall be closed at a definite time every day, this checkbox shall be marked.  
**Hour:** 00 – 23  
**Minute:** 00 - 59

### 18.1.6 Miscellaneous

- ☒ **Use daylight saving time:** According to the current EU regulations, i.e. it starts last Sunday in March 01:00 GMT one hour ahead<sup>118</sup> and stops last Sunday in October 01:00 GMT one hour backwards.<sup>119</sup>
- ☒ **Use special menu during fire alarms:** During the fire alarm presentation, a special fire alarm menu can be used.<sup>120</sup> (If this menu is excluded it is a violation to the EN54-2 standard). See also EBL512 Operating instructions, chapter "Fire alarm menu".
- **Silence buzzer by door switch:** If the buzzer in the c.i.e. shall be silenced when the door is opened, this checkbox shall be marked<sup>121</sup> but this is a violation to the EN54-2 standard.
- ☒ **Enhanced disablements:** Disabled alarm points will not activate pre-warning, fire alarm or fault.  
If this function is re-enabled, fault can be activated from disabled alarm points but not pre-warning or fire alarm. This is a violation to the EN54-2 standard.
- **Point alarm presentation:** If fire alarms shall be presented the same way as in EBL512 SW version  $\leq 1.43.x$  (i.e. Zone – Address for all fire alarms), this checkbox shall be marked but this is a violation to the EN54-2 standard.

---

<sup>118</sup> I.e. in Sweden: 02:00 one hour ahead to 03:00.

<sup>119</sup> I.e. in Sweden: 03:00 one hour backwards to 02:00.

<sup>120</sup> Not valid in Chinese convention.

<sup>121</sup> Required when the "old" front is used.

- ☒ **Flash LED on MCP 3333, 3339:** The manual call point's built-in LED will flash each time the c.i.e. communicates with the call point. If this option is disabled the LED is switched off until the call point is operated.

## 18.2 Time channels

The control unit RTC (real time clock) controls time channels 1-4.

Time channels can be used to:

- disable and re-enable alarm points
- set alert annunciation ON / OFF
- activate programmable control outputs
- set alternative alarm algorithm for analog detector types 33xx ON / OFF

The properties for each **Time channel** (1-4) and each **Day of the week** (1-8) have to be set.

Day of week	Time 1 hh=0-23 mm=0-59	ON OFF √ = ON	Time 2	ON OFF √ = ON	Time 3	ON OFF √ = ON	Time 4	ON OFF √ = ON
1	hh : mm	<input type="checkbox"/>	hh : mm	<input type="checkbox"/>	hh : mm	<input type="checkbox"/>	hh : mm	<input type="checkbox"/>
2	hh : mm	<input type="checkbox"/>	hh : mm	<input type="checkbox"/>	hh : mm	<input type="checkbox"/>	hh : mm	<input type="checkbox"/>
3	hh : mm	<input type="checkbox"/>	hh : mm	<input type="checkbox"/>	hh : mm	<input type="checkbox"/>	hh : mm	<input type="checkbox"/>
4	hh : mm	<input type="checkbox"/>	hh : mm	<input type="checkbox"/>	hh : mm	<input type="checkbox"/>	hh : mm	<input type="checkbox"/>
5	hh : mm	<input type="checkbox"/>	hh : mm	<input type="checkbox"/>	hh : mm	<input type="checkbox"/>	hh : mm	<input type="checkbox"/>
6	hh : mm	<input type="checkbox"/>	hh : mm	<input type="checkbox"/>	hh : mm	<input type="checkbox"/>	hh : mm	<input type="checkbox"/>
7	hh : mm	<input type="checkbox"/>	hh : mm	<input type="checkbox"/>	hh : mm	<input type="checkbox"/>	hh : mm	<input type="checkbox"/>
8	hh : mm	<input type="checkbox"/>	hh : mm	<input type="checkbox"/>	hh : mm	<input type="checkbox"/>	hh : mm	<input type="checkbox"/>

Day of week 1 = Monday

Day of week 8 = National holiday

*Figure 24. Properties for one time channel.*

All (52) weeks of a year have the same settings. When national holidays are in the middle of a week, separate ON/OFF times can be set for these holidays, i.e. day of the week 8 in the table. National holiday's dates are to be set separately in the "National holidays" tab.

## 18.3 Time activation outputs

See also chapter "Time activation", page 67.

"Time Activation Output" 1-10 can be programmed. For each Time Activation Output the properties have to be set:

**No.:** X = The number of the Time Activation Output, 1-10. Information only, can not be changed.



**Logical name:** Normally not changed but each Time Activation Output can have a name indicating what it is meant for, e.g. "Alarm devices".

**Type:** Steady (continuous), Intermittent, One pulse, Steady – delayed activation, Intermittent - delayed activation, One pulse - delayed activation **or** Steady – delayed de-activation.

**Delay time:** Can be set, when required, to 0-255 x **0.8 sec.**

**Pulse length:** Can be set, when required, to 0-255 x **0.8 sec.**

**Pulse off:** Can be set, when required, to 0-255 x **0.8 sec.**

**De-activation:** Can be set, when required, to 0-255 x **0.8 sec.**

Min. = 1 x 0.8 = 0.8 sec. Max. = 255 x 0.8 = 204 sec. = 3 min. 24 sec.

## 18.4

### Door open

#### 18.4.1

#### Indication door open affected by

- ☉ **Door in any control unit or any external FBP (default):** Door open in a C.U. is indicated by LED "Door open" / "Key switch" in all C.U:s and in all ext. FBPs. Door open in an ext. FBP is indicated by LED "Door open" / "Key switch" in all C.U:s and in all ext. FBPs.
- **Door in any control unit:** Door open in a C.U. is indicated by LED "Door open" / "Key switch" in all C.U:s and in all ext. FBPs. Door open in an ext. FBP is indicated by LED "Door open" / "Key switch" in that ext. FBP only.
- **Door in control unit or external FBP connected to own control unit:** Door open in a C.U. is indicated by LED "Door open" / "Key switch" in the C.U. and all ext. FBPs connected to that C.U. Door open in an ext. FBP is indicated by LED "Door open" / "Key switch" in the C.U. and all ext. FBPs connected to that C.U.
- **Door in control unit:** Door open in a C.U. is indicated by LED "Door open" / "Key switch" in the C.U. and in all ext. FBPs connected to that C.U. Door open in an ext. FBP is indicated by LED "Door open" / "Key switch" in that ext. FBP only.

#### 18.4.2

#### Disablement of routing equipment

- ☉ **No disablement (default):** Door open in a C.U. or an ext. FBP will **not** disable the outputs for routing equipment (Fire brigade and fault tx).
- **Disable by door in any control unit:** Door open in any C.U. will disable the outputs for routing equipment (Fire brigade and fault tx) in all C.U:s.
- **Disable by door in any control unit or any external FBP:** Door open in any C.U. or any ext. FBP will disable the outputs for routing equipment (Fire brigade and fault tx) in all C.U:s.

## 18.5 National holidays

Up to twenty national holidays can be set for the whole system.<sup>122</sup> For each national holiday the **Year** (2001-2038), **Month** (01-12) and **Day of the Month** (01-31) have to be set. "Add" to or "Delete" from the **Date** list. "Annual repetition" can be set if a holiday returns the same date every year. (The year will be deleted for these days.)

Function: Normally the Day of week 1-7 ON/OFF times are valid. A national holiday has higher priority, i.e. the Day of week 8 ON/OFF times are valid for this day instead of the normal times.

## 18.6 Alarm algorithms

For each analog detector programmed (via Win512) is an alarm algorithm selected (and when required an alternative alarm algorithm). A number of algorithm "Properties" are displayed under this tab. Detector type, Logical and Short names can be changed. The Short name ( $\leq$  six characters) is shown in menu H4/U5<sup>123</sup>. Level 1 or Level 2 can be selected (see chapter "Win512 Tools menu", page 101):

In **Level 1** it is also possible to change:

The pre-warning and the heavy smoke / heat alarm algorithm parameters for smoke and heat detectors.

In **Level 2** it is also possible to change:

The fire alarm algorithm parameters for smoke and heat detectors.

### 18.6.1 Classic smoke detectors' properties

**Detector:** 2300(ION)  
 2210(ION2) = ION2200  
 2304(OPT)  
 2210(OPT2) = OPT2202  
 AUT

**Logical name:** Classic

**Short name:** Class

**Algorithm parameters:** Default values, see table:

	2300 (ION)	2210 (ION2)	2304 (OPT)	2210 (OPT2)	AUT
Offset, Pre-warning	10	20	10	20	45
Offset, Fire alarm	18	35	13	25	60
Offset, Heavy smoke	22	45	22	45	100
Sampling interval	2	2	3	3	1

<sup>122</sup> Note! ON/OFF times for each time channel (1-4), day of week = 8 are to be set in the "Time channels" tab.

<sup>123</sup> In "British Standard Marine Application" convention  $\leq$  five characters. In this convention, the alarm algorithm can also be changed via menu H4/U5.

**NOTE! If any of these values are changed it might be a violation to the EN54-2 standard.**

Sampling interval:

1 = 3 values over alarm level to activate alarm.

2 = 5 values over alarm level to activate alarm.

3 = 7 values over alarm level to activate alarm.

### 18.6.2 Heat detectors' (3308, 3309 and 3316) properties

**Detector:** 3308(AHD), also valid for 3309  
 3316 HEAT (AMD), i.e. the heat detector part when decision algorithm is not selected.

**Logical name:** Class A1, Class A2 (S) or Class B (S).

**Short name:** A1, A2 or B

**Algorithm parameters:** Default values, see table:

	3308 (3309) (AHD)			3316 HEAT (AMD)			For 3308 (3309)
	A1	A2	B	A1	A2	B	
Level, Pre-warning	92	100	128	46	50	64	x 0.5° C
Level, Fire alarm	112	120	148	56	60	74	x 0.5° C
Level, Heavy alarm	180	180	180	90	90	90	x 0.5° C
Rise time <sup>A</sup>	8			4			x 0.5° C per min.
Step down <sup>A</sup>	20			10			x 0.5° C

**NOTE! If any of these values are changed it might be a violation to the EN54-2 standard.**

<sup>A</sup> Rate-of-rise > 8 x 0.5 = 4° C per minute gives an alarm level temperature step down of 20 x 0.5 = 10° C

### 18.6.3 Smoke detectors' (3304 and 3316) properties

**Detector:** 3304(OPT)  
 3316 SMOKE (AMD), i.e. the smoke detector part when decision algorithm is not selected.

**Logical name:** L-15 Low sens. 15s, L-35 Low sens. 35s, N-15 Normal sens. 15s, N-35 Normal sens. 35s, H-15 High sens. 15s and H-35 High sens. 35s.

**Short name:** L-15- L35, N-15, N-35, H-15 and H-35.

**Algorithm parameters:** Default values, see table:

	3304 (OPT)						3316 SMOKE (AMD)					
	L-15	L-35	N-15	N-35	H-15	H-35	L-15	L-35	N-15	N-35	H-15	H-35
Offset, Smouldering	18	18	15	15	12	12	18	18	15	15	12	12
Offset, Pre-warning	26	26	22	22	18	18	26	26	22	22	18	18
Offset, Fire alarm	36	36	30	30	24	24	36	36	30	30	24	24
Level, Heavy alarm	150	150	150	150	150	150	120	120	120	120	120	120
Step value <sup>A</sup>	6	2	5	2	4	2	12	4	10	4	8	4

**NOTE!** If any of these values are changed or if slow detection time (X-35) and/or low sensitivity (L-xx) is used, it might be a violation to the EN54-2 standard.

<sup>A</sup> The "Step value" is used in the alarm algorithm.

#### 18.6.4 Multi detector's (3316 & decision algorithm) properties

**Detector:** 3316 SMOKE (AMD), i.e. the 3316 detector when decision algorithm is selected.

**Logical name:** Decision algorithm

**Short name:** Dec (Shown in menu H4/U5).

**Algorithm parameters:** Default values, see table:

	3316 SMOKE (AMD)
Offset, Smoke Pre-	50
Offset, Smoke alarm	58
Level, Heat Pre-warning	50
Level, Heat alarm	58

**NOTE!** If any of these values are changed, it may fasten or delay the alarm activation.

### 18.7 System information

In this tab you can **read** the following information:

**Logical name**

**Number of Control units**

**Number of addresses**

**Number of expansion cards**

When some name is changed, added or removed units, this information is updated.

## 18.8 Time alert annunciation

See also chapter "Alert annunciation", page 92.

**Acknowledgement time: 6 x 5 sec.**

6 is default. 1-99 is possible, i.e. 5-495 sec. (= 8 min. 15 sec.)

**Investigation time: 3 min.**

3 is default. 1-40 is possible

**Number of zones: 1**

1 is default. 1-4 is possible

**Multiple alarms allowed within same zone** (default)

If only one alarm point within the zone is allowed to activate alert annunciation, this checkbox shall be unmarked.

NOTE! According to EN54-2, the total delay of fire alarm routing equipment (Acknowledge time + Investigation time) must not exceed 10 minutes.

## 18.9 Two zone dependency

See also chapter "2-zone / address dependence (co-incidence alarm)", page 90.

**Group Zone:** A list box showing all the programmed zones in the system (i.e. the zones have to be programmed as "Two unit dependent" in Win512) before they can be programmed to a two zone dependency group).

Default for all zones is Group 0 (= no two zone dependency).

Click the current group number (0) for the zone to be programmed.

The zone number displays in the **Zone** box (down to the right in the dialog box).

Type the new group number in the **Group** box.

Click "Apply" to accept and update the **Group Zone** list box.

The group number for the zone is now changed which is displayed in the **Group Zone** list box.

When all changes have been done check that two or more zones are programmed to each group.

## 19 **Compatibility**

---

Analog smoke detector (sensor) types 2200 and 2202 plugged in analog base 2210, can be connected to the COM loops.

See also chapter "Analog Detectors" (types 33xx), page 37.

Regarding "older" EBL systems (EBL2000 / 1000), contact MFSTech for advice.

---

## 20 Cable types

---

A fire alarm installation is a safety installation and it is important that the cables used, are correct types and according to national regulations. Fire alarm cables should, when possible, be installed away from other cables, to avoid disturbances from these.

### 20.1 TLON Network cables

See dwg. 512-49 and separate TLON Technical description.

### 20.2 COM loop cables

Loop topology is used for highest safety, i.e. the cable, connected in the control unit, returns back to the control unit. In case of a break on the loop, communication in two directions starts. See dwg. 512-41, -51, -52 -53, -61 and -62.

Cable length is depending on number and type of loop units, etc. See chapter "COM loop cable length", page 119 and dwg. 512-01.

ELKY 2 x 1 mm (0.75 mm<sup>2</sup>) or equivalent (twisted pair).

ELKY 10 x 2 x 1 mm or equivalent, when feeder line is required.

If screened cable is used, the screen shall be connected close to each loop unit and only incoming (or outgoing) screen to the control unit earth.

### 20.3 BS4 loop cables

Loop topology is used, see dwg. 512-48.

Normally, you connect an existing installation to the EBL512 control unit (Autronica interface board 1584). If new cables are to be installed, see Autronica BS 100 documentation.

### 20.4 Ext. FBP / Data converter cables

RS-485. See dwg. 512-47.

Cable length  $\leq$  1200 m to the furthest away situated ext. FBP / Data converter.

LiYCY (TP) 2 x 2 x 0.75 mm<sup>2</sup> or equivalent (twisted pairs).

### 20.5 Conventional zone line cables

See dwg. 512-46, -51, -52, -54, -55, -56 and -57.

Inputs to 8 zones expansion board 1580, Addressable zone interface 2226 / 2335, Addressable IS zone interface 2821, Addressable base 2330 external line and Multipurpose I/O unit 3361.

EKKR 2 x 0.6 mm (0.3 mm<sup>2</sup>) or equivalent. Max. 50 ohm cable resistance.

## **20.6 Alarm device cables**

Alarm devices (sounders, etc.), see dwg. 512-42 and 61.

EKKR 2 x 0.6 mm (0.3 mm<sup>2</sup>) or equivalent.

EKKR 10 x 2 x 1 mm (0.75 mm<sup>2</sup>) or equivalent, when feeder line is required.

## **20.7 Other cables**

External indicator (LED), 2 inputs / 1 output unit 2222, door release magnets, etc. E.g:

EKKR 2 x 0.6 mm (0.3 mm<sup>2</sup>) or equivalent.



## 21 COM loop cable length

---

The cable length and max. COM loop current, are depending on the number and type of loop units and the cable type, see Figure 25 and Figure 26, page 120 and 121 respectively.

**One** of the graphs has to be used depending on which type of units that are connected to the COM loop. Start checking the terms below for Graph 1, then Graph 2 and finally Graph 3.

### 1. Graph with square dots

Has to be used when at least one of the following units are used:

2335 / 3361<sup>124</sup> + (2316, 2317, 2318 or 2321 plugged in a 2324)  
2330 + (2316, 2317, 2318 or 2321 plugged in 2330 or plugged in a 2324 connected on the external line)

### 2. Graph with circular dots

Has to be used when at least one of the following units are used:

2235 / 2236  
2262 / 2263  
2265  
2300 / 2304  
2276  
2226 / 2821  
2330 + (all conventional types **except** 2316, 2317, 2318 or 2321 plugged in 2330 or plugged in a 2324 connected on the external line.)  
2335 / 3361<sup>124</sup> + (all conventional types **except** 2316, 2317, 2318 or 2321 plugged in a 2324)  
2333  
2340 / 2341  
2210 + (2200 or 2202)

### 3. Graph with no dots

Can be used when only the following units are used:

2370  
3312 + (3304, 3308 or 3316)  
3309  
3333 / 3339  
3361 when the monitored input is not used as a zone line input (Z)

Here follow two figures, showing graphs for maximum conductor resistance and maximum cable length respectively.

The graphs are valid for cable type ELKY 2 x 1 mm (0.75mm<sup>2</sup>).

---

<sup>124</sup> The monitored input used as a zone line input (Z).

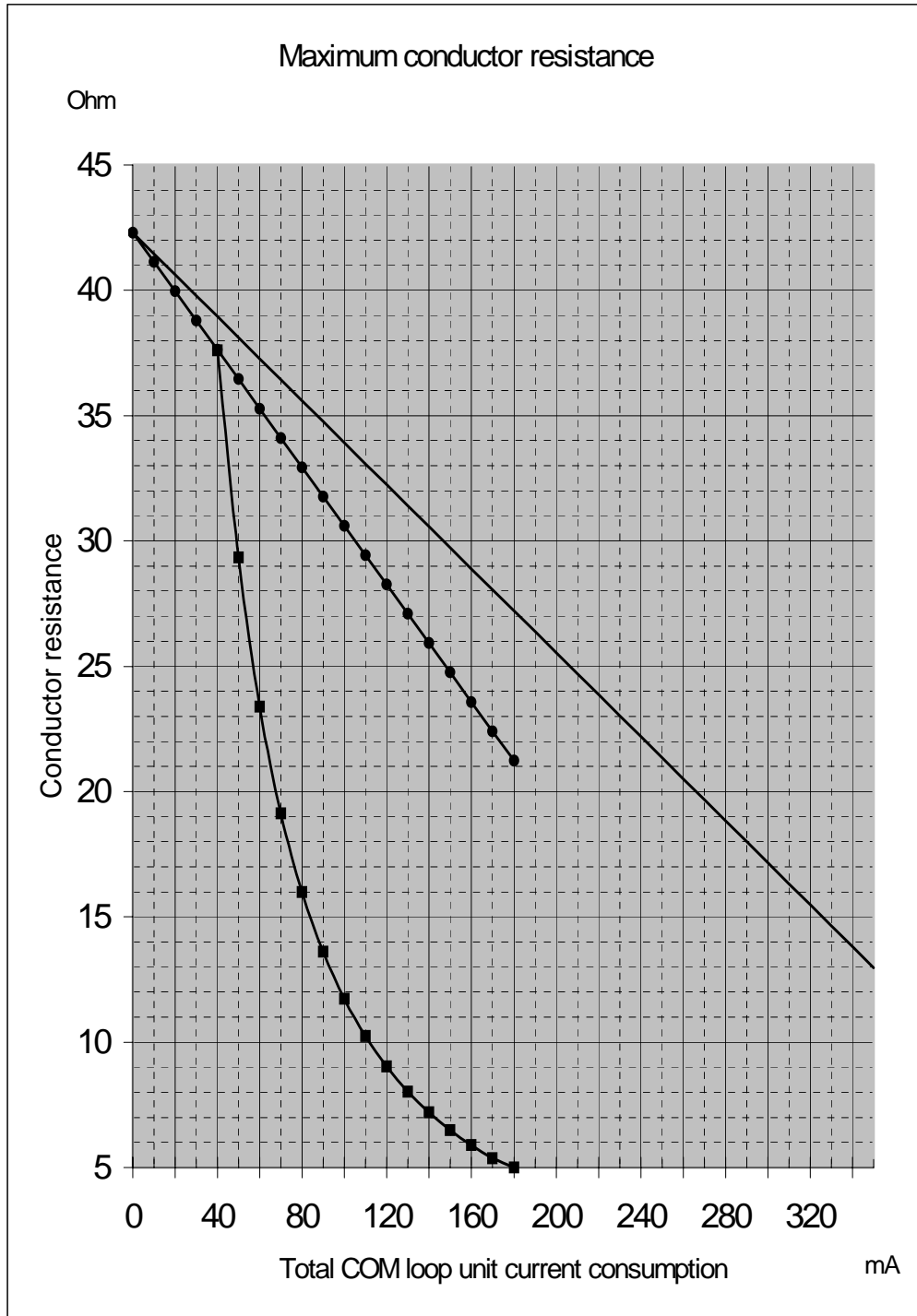

Figure 25. Graphs showing the conductor resistance in relation to the COM loop units' total current consumption. **NOTE!** All graphs start at "0 mA" but graph 1 and 2 ends at "180 mA" and graph 3 ends at "350 mA". End of graph = max. allowed loop current.

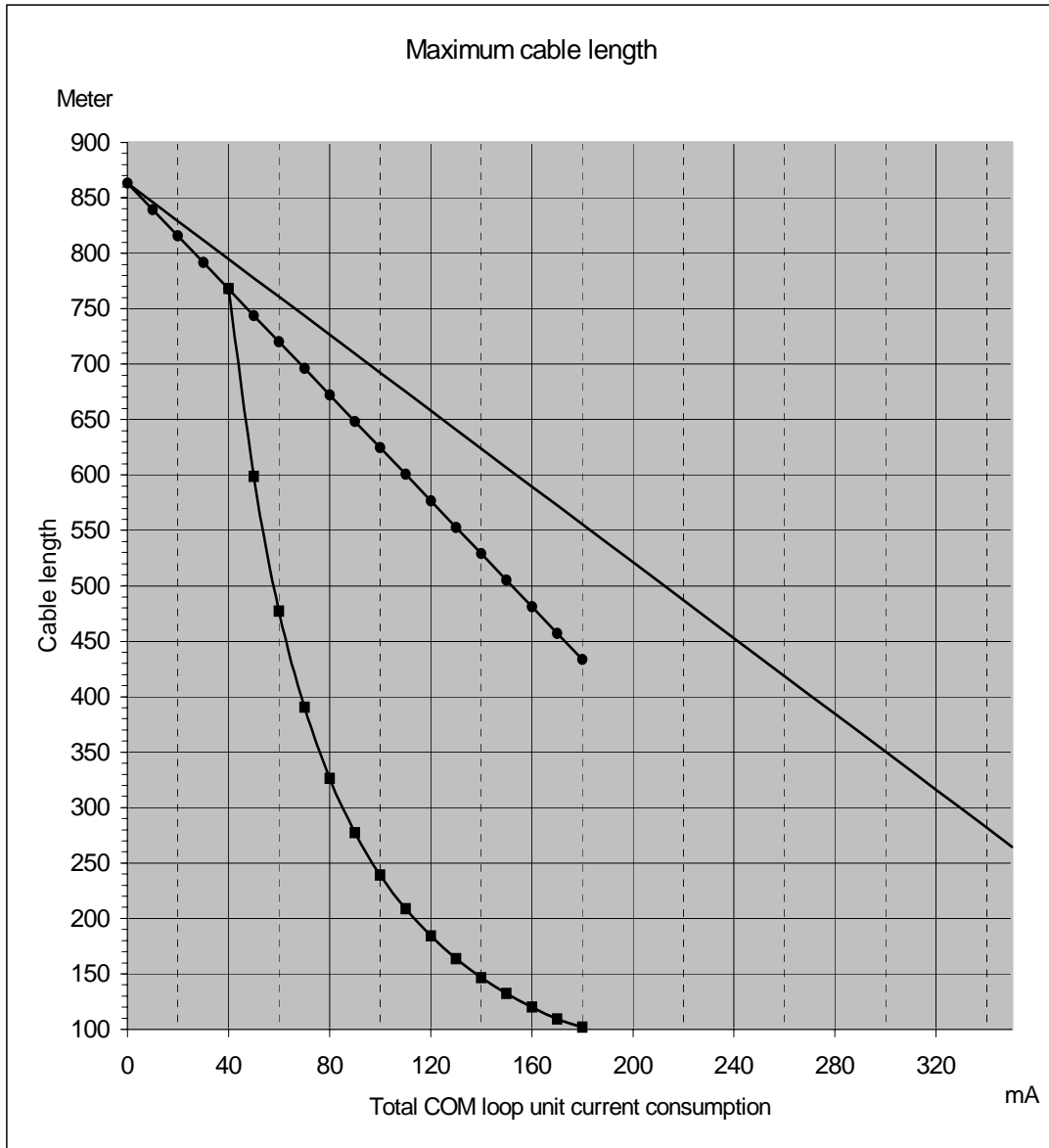

Figure 26. Graphs showing the cable length in relation to the COM loop units' total current consumption. Valid for cable type ELKY 2x1 mm (conductor resistance = 24.5 ohms / km). **NOTE!** All graphs start at "0 mA" but graph 1 and 2 ends at "180 mA" and graph 3 ends at "350 mA". End of graph = max. allowed loop current.

## 22 Current consumption

The different loop units have different current consumption. Note that some units have much higher current consumption in "active state". To check the current consumption on the COM loops, cable lengths, etc., the tables below can be used. See also dwg. 512-01 and chapter "COM loop cable length", page 119.

Also, to get a total current consumption overview and to check if the battery capacity is enough, the tables below can be used.

The current consumption is shown in **Normal state** (quiescent) and in **Alarm state** (active).

See also chapter "Power supply", page 126.

Unit	Normal state (quiescent) (mA)	Alarm state (active) (mA)
Control unit (without printer) 1548	140	310
Control unit (with printer) 1549	160	340
Control unit (without front and without printer) 1550	120	150
Battery charging current	max. 2000 <sup>125</sup>	0 / 2000 <sup>126</sup>
8 zones expansion board 1580	50	50 <sup>127</sup>
8 relays expansion board 1581	15	15
Ext. FBP interface board 1582, no units connected	15	15
German FBP interface board 1583, no units connected	15	15
Autronica interface board 1584 (+ four BS4 loops) <sup>128</sup>	55+(4x30)=175	55+(4x60)=295
TLON connection board 1590	approx. 20	approx. 20

<sup>125</sup> Battery charging current, at approx. 27 V, is max. 1.2 A. This results in a battery charging current, at 24 V, of max. 2 A. (lower voltage results in higher current, i.e. 1.2 A + 70% = 2 A)

<sup>126</sup> In case of a fire alarm the battery charging is turned off.

<sup>127</sup> When conventional detectors (with alarm resistor) are used, add 65 mA per zone activated. When detectors with a closing contact (short circuit results in a fire alarm) are used, add 86 mA per zone activated.

<sup>128</sup> The board has four BS4 loops. Current consumption is depending on the number and types of units connected to each loop. The values in the table shows the **max.** values, i.e. 99 units connected to each loop.

Unit	Normal state (quiescent) (mA)	Alarm state (activated) (mA)
Analog smoke detector 2300 / 2304 + analog base 2312 <sup>129</sup>	1.7 / 1.8	3.7 / 3.8
Analog smoke detector 3304 + analog base 3312 <sup>130</sup>	0.3	2.3
Analog heat detector 3308 + analog base 3312 <sup>130</sup>	0.3	2.3
Analog heat detector, enclosed 3309 <sup>130</sup>	0.2	1.7
Analog multi detector 3316 + analog base 3312 <sup>130</sup>	0.55	2.55
Addressable base 2330 + detector. Incl. external line. <sup>129</sup>	1.7 3.5	3.9 13.2 <sup>131</sup>
Addressable heat detector 2340 / 2341 <sup>129</sup>	2	5
Addressable zone interface, isolated 2226 <sup>132</sup>	3	6
Addressable IS zone interface 2821 <sup>132</sup>	3	6
Addressable zone interface 2335	5	20
Addressable 8 inputs unit 2276	2	6
Addressable manual call point 2333	2	5
Addressable manual call point 3333	2	5
Display unit 2235 <sup>133</sup>	12	20
By ext. power supply of the display unit	3	3
Display unit 2236 <sup>134</sup>	12	12
By ext. power supply of the display unit	3	3

NOTE! On each COM loop, up to 5 sensors / detectors can have their LEDs lit at the same time.

<sup>129</sup> Extern LED current consumption: add 1 mA.

<sup>130</sup> Extern LED current consumption: add 2 mA.

<sup>131</sup> Alarm state on detector and external line: 15.4 mA

<sup>132</sup> 2226 / 2821 also require external power supply, 24V DC, 30 mA.

<sup>133</sup> The values in the table shows current consumption from COM loop. (Active: 12 mA + LED "Acknowledge" lit 8 mA = 20 mA). Display backlight require external 15-28 V, 110 mA (at 15 V). By external power supply (15-28 V) of the display unit: 12 / 120 mA (at 15 V). LED "Acknowledge" lit: add 8 mA.

<sup>134</sup> The values in the table shows current consumption from COM loop. Display backlight require external 15-28 V, 110 mA (at 15 V). By external power supply (15-28 V) of the display unit: 12 / 120 mA (at 15 V).

Unit	Normal state (quiescent) (mA)	Alarm state (activated) (mA)
Addressable short circuit isolator 2370	15	5 <sup>135</sup>
Addressable 4 relay outputs unit 2265	2	2
Addressable 4 outputs unit (with power supply) 2262 <sup>136</sup>	6	6
Addressable 4 outputs unit (without power supply) (2263). <sup>137</sup>	6	6
Addressable multipurpose I/O unit 3361	2.2	max. 12
Addressable siren 3377 <sup>138</sup>		
Addressable sounder base 3378 <sup>138</sup>		

---

<sup>135</sup> By a short circuit approx. 5 mA (that insignificant in this state).

<sup>136</sup> The values in the table shows current consumption from COM loop. Current consumption (q / a) by battery power supply (24 V):  $\leq 350$  ( $\leq 50$  after 10 min.) /  $\leq 3070$  mA (depending on connected equipment, e.g. door release magnets in **quiescent** state and alarm devices in **alarm** state).

<sup>137</sup> The values in the table shows current consumption from COM loop. Current consumption (q / a) by 2262 or external power supply (24 V):  $\leq 330$  ( $\leq 50$  after 10 min.) /  $\leq 3070$  mA (depending on connected equipment, e.g. door release magnets in **quiescent** state and alarm devices in **alarm** state).

<sup>138</sup> This unit might still be under construction.

Unit	Normal state (quiescent) (mA)	Alarm state (activated) (mA)
Routing equipment (Fire brigade tx / Fault tx)	Acc. to the producer	Acc. to the producer
External FBP 2425 (with printer) <sup>139 140 141 142</sup>	85	100
External FBP 2426 (without printer) <sup>139 141 142</sup>	85	100
<del>External FBP 2427 (without printer) <sup>139 141</sup></del>	<del>85</del>	<del>100</del>
External Presentation Display 2428 <sup>141 143</sup>	36	116
Data converter BEST (Nurse call system) 2290 <sup>141</sup>	70	70 <sup>144</sup>
Data converter Tateco (Ascom paging system) 2291 <sup>141</sup>	70	70 <sup>144</sup>
Data converter EBL-talk 2292 <sup>141</sup>	70	70 <sup>144</sup>
<del>Data converter Multicom 2293 <sup>141</sup></del>	<del>70</del>	<del>70<sup>144</sup></del>
<del>Data converter FBP status information 2294 <sup>141</sup></del>	<del>70</del>	<del>70<sup>144</sup></del>
Alarm devices (sounders, etc.)	0	Acc. to the producer
Door release magnets	Acc. to the producer	0
<del>2 inputs / 1 output unit 2222</del>	<del>0</del>	<del>1</del>
<del>Timer 6339)</del>	<del>32</del>	<del>90</del>
<del>GW512<sup>145</sup></del>	<del>100</del>	<del>100</del>
<del>Alert annunciation controller 2232).</del>	<del>6</del>	<del>75<sup>146</sup></del>

<sup>139</sup> FBP display backlight add 100 mA.

<sup>140</sup> Active printer add 200 mA.

<sup>141</sup> Normally power supplied from Ext. FBP interface board 1582. When required ext. power supply can be used.

<sup>142</sup> Regarding External FBP 2425 / 2426: A "new version" (p.c.b. number 2425-3A, CFG: 1) has approx. the same current consumption as External Presentation Display 2428.

<sup>143</sup> The values in the table are valid by 24 V. By 22 V: 37 / 124 mA. By 20 V: 38 / 132 mA. By 18 V: 40 / 145 mA. By 16 V: 42 / 160 mA.

<sup>144</sup> Add max. 50 mA per driver output used.

<sup>145</sup> Should be power supplied from the EBL1000 / 2000 main control unit.

<sup>146</sup> Output for ext. indicator max. 500 mA.

## 23 Power supply

Normally the EBL512 control unit is powered by the built-in rectifier (230 V AC / 24 V DC  $\pm 1\%$ , 4.5 A).

By mains failure (loss of 230 V AC) the control unit is powered by a built-in battery<sup>147</sup> (2 pcs. of Sealed Lead-Acid batteries, 12 V, 24 Ah). The batteries and the rectifier are connected to the Charger board 1557, which also handles the battery charging.

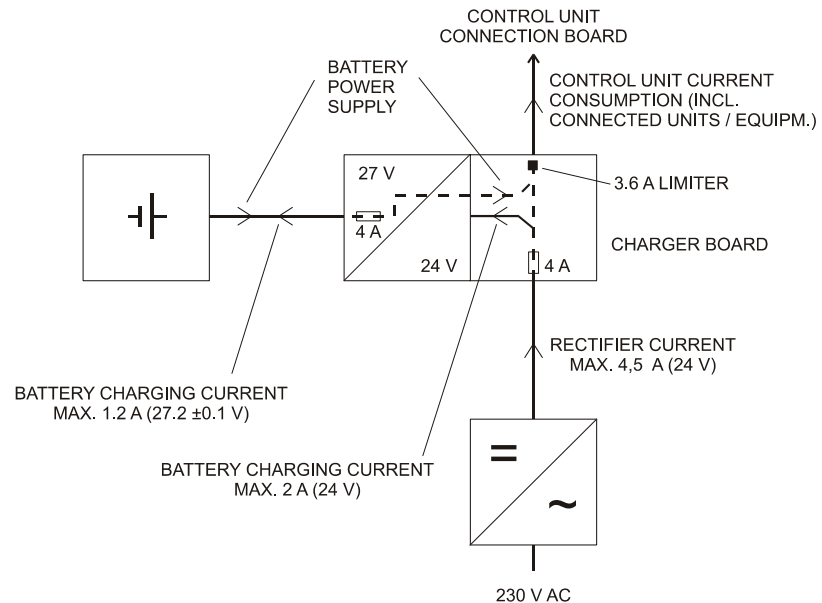

Figure 27. EBL512 power supply block diagram.

EBL512 is a very flexible system, i.e. number of and types of loop units, number of and types of expansion boards, ext. FBPs, ext. equipment, etc. can vary from one control unit to another.

For each control unit, the current consumption in **Normal state** (quiescent) and in **Alarm state** (activated) have to be calculated to get a total current consumption overview and to check that the rectifier will not be overloaded and if the battery capacity is enough.

NOTE! According to EN 54-4, section 5.3.1 b), *The charger shall be designed and rated so that a battery discharged to its final voltage can be recharged to at least 80% of its rated capacity within 24 hours and to its rated capacity within another 48 hours.*

If this section is to be followed, only the 24 Ah battery can be used (because of the max. 1.2 A charging current) and  $I^{TN}$  according to the table in chapter "Battery", page 128.

Use the values in chapter "Current consumption", page 122, to calculate the following current consumptions:

<sup>147</sup> Not incl. in the Control unit type no. 1548, 1549 & 1550.



- $I^{CN}$  = current consumption for the control unit (C) in normal state (N).
- $I^{RN}$  = current consumption for all other equipment<sup>148</sup> (R) in normal state (N).
- $I^{CA}$  = current consumption for the control unit (C) in alarm state (A).
- $I^{RA}$  = current consumption for all other equipment<sup>149</sup> (R) in alarm state (A).

## 23.1 Rectifier

The rectifier technical data are 24 V DC ( $\pm 1\%$ ) and max. 4.5 A but the charger board input has a **4 A** fuse and the output is limited to **3.6 A**. See also Figure 27, page 126.

Calculate and check the total (T) current consumption for the control unit (C) and all other equipment (R) in normal state (N) and in alarm state (A).

- $I^{TN} = I^{CN} + I^{RN}$
- $I^{TA} = I^{CA} + I^{RA}$

Explanations regarding the normal state ( $I^{TN}$ ):

$I^{TN}$  shall normally be  $\leq 2$  A (4 A – 2 A batt. charg. = 2A).

$I^{TN}$  is recommended to be  $\leq 0.8$  A because this results in 30 hours battery backup time (theoretical value) with 24 Ah battery.

If  $I^{TN} > 2.5$  A (even for a short time) fault is activated and the following fault message is shown:

```
FAULT: CU xx too high current consumption
Date: MM-DD   Time: HH:MM
```

The battery charging is turned off until  $I^{TN} \leq 2.5$  A.<sup>150</sup>

Explanations regarding the alarm state ( $I^{TA}$ ):

<sup>148</sup> External equipment connected to the control unit (e.g. ext. FBPs, door release magnets, relays, etc.).

<sup>149</sup> External equipment connected to the control unit (e.g. ext. FBPs, sounders, relays, etc.).

<sup>150</sup> A fault will be activated after 1-300 minutes (programmable in Win512), max 30 min. according to EN54-2 standard. The following fault message will be shown after the time delay:

```
FAULT: Mains, control unit xx
Date: MM-DD   Time: HH:MM
```

$I^{TA}$  shall be  $\leq 3.6$  A. When fire alarm is activated the battery charging is turned off. Fault will not be activated in this case.

## 23.2 Battery

Find out the required battery backup time<sup>151</sup>, both in normal state and in alarm state.

To calculate the battery capacity, the total current consumption in normal state,  $I^{TN}$ , and in alarm state,  $I^{TA}$ , shall be multiplied with the battery backup time.

- $Q^N$  (Ah) =  $I^{TN}$  (A) x battery backup time in normal state (h)
- $Q^A$  (Ah) =  $I^{TA}$  (A) x battery backup time in alarm state (h)

$$Q = \text{Calculated battery capacity (Ah)} = Q^N + Q^A$$

Normally you shall round off the calculated capacity (upwards) and add 10% because the battery voltage at the end of a discharging period is not the same as at the start.

A table showing the relation between the total current consumption in normal state ( $I^{TN}$ ) and the backup time with a 24 Ah battery. Note! The values are calculated and gives only a rough idea of the backup time.

$I^{TN}$ (A)	Backup time (hours)
1.0	24
0.8	30
0.6	40
0.4	60
0.2	120

## 23.3 Form / Table of current consumption

Some national regulations require different forms / tables regarding current consumption, to be filled in. In such cases shall an ampere meter be used, instead of calculating the current consumption.

---

<sup>151</sup> According to national regulations, customer demands, etc.

## 24 SW versions

Due to continual development and improvement, different SW versions are to be found.

Different SW versions can be found on different markets.

The SW versions listed below were the valid ones when this document was written (the date of this document or date of revision).

SW for:	Latest version	Required version
1548 / 1549 / 1550; EBL512	2.1.2 / 2.1.3 <sup>152</sup>	2.1.1
1580; 8 zones expansion board	3.0	2.1
1581; 8 relays expansion board	3.0	1.2
1582; Ext. FBP interface board	3.0	3.0
1583; German FBP interface board	3.0	3.0
1584; Autronica interface board	3.0	3.0
1590; TLON connection board	1.2	1.1
2235 / 2236 (2237 / 2238); Display unit	2.30 (2.30)	2.21 (2.30)
2262 / 2263; Addr. 4 outputs unit	3.22	3.1
2425 / 2426; Ext. FBP	2.03	2.03
<del>2427; Ext. FBP</del>	<del>2.04</del>	<del>2.04</del>
2428; Ext. Presentation Display	2.05	2.05
Win512	2.1.1 / 2.1.2 <sup>152</sup>	2.1.1
TLON Manager	1.11	1.11
TLON DDE	2.0	2.0

<sup>152</sup> **NOTE!** Latest version can vary depending on the market / country.

## 25 Technical data

---

### Voltage

Primary (V AC): 230

System (V DC): 24<sup>153</sup>

### Current consumption

Quiescent / active: Depending on type (1548-1550), etc. See chapter "Current consumption", page 122

### Ambient temperature (°C)

Operating: 0 to +40

Storage: -40 to +70

### Ambient humidity (%RH)

max. 90, non condensing

### Ingress protection rating

IP 22 (estimated)

### Size H x W x D (mm)

610 x 400 x 175. See also drawing 512-11

### Weight (kg)

1548: 17.6

1549: 18

1550: 17.4

### Colour

Metal cabinet: light grey (NCS S 1500-N / PMS Cool Gary 2)

### Approvals

Conforms with EN 54-2 and EN 54-4

---

<sup>153</sup> 24 V is the rated voltage. The operating voltage can be higher / lower.

## 26 Limitations

### 26.1 User definable texts

At least 617<sup>154</sup> "User definable texts" can be programmed per c.i.e.  
 The texts are to be distributed amongst the following:

- Alarm points (Zone / Address)
- Alarm Zones
- Interlocking Combinations
- Ext. faults

### 26.2 C.i.e. / System

Max. number of "items" per c.i.e. and per system respectively (when nothing is specified for the c.i.e. the same is valid as for the system):

Item	C.i.e.	System
General fire alarm inputs	250	
External fault inputs		50
Programmable outputs (=control expressions) <sup>155</sup>	200	
Interlocking Combinations	200	1000 <sup>156</sup>
Fire alarms (presented in the c.i.e. display as ZONE and/or ZONE-ADDRESS)		512
Faults		200
Disabled zones		512
Disabled alarm points (zone/address) + Disabled COM loops		200 <sup>157</sup>
Disabled outputs		200 <sup>158</sup>
Disabled interlocking outputs		200 <sup>159</sup>
Sensors activating SERVICE signal		100

<sup>154</sup> In Chinese convention, 792 texts. Note! The 90 most common words will be stored in a special list, which gives more memory available for the rest of the texts, i.e. the **exact** number of texts is impossible to specify.

<sup>155</sup> Approx. 1000 trigger conditions can be used in these control expressions.

<sup>156</sup> Max 100 user definable texts can be displayed "at the same time".

<sup>157</sup> Zone/address disabled via time channel not included.

<sup>158</sup> Control OFF (menu H2/B8) and Alarm device OFF (menu H2/B9) not included.

<sup>159</sup> Interlocking outputs disabled via "000/00" in menu H9/C4 not included.

## **27 National regulations**

---

When planning a fire alarm installation, national regulations, customer demands, etc. have to be followed.

EBL512 is very flexible. Many functions / facilities are built-in the system, e.g. in the SW and Win512.

When downloading SW and SSD, different settings, conventions, languages, etc. can be set to fulfil national regulations.

## **28 Drawings / connection diagrams**

---

All dimensions quoted are approximate only and subject to change without notice, as are other technical features and data, resulting from continual development and improvement.

## 29 Revision history

---

### Revision 1

Elucidation and small corrections.

Chapter "Fire Door Closing", page 81: "Type of output" and BS4 information. Chapter 16.19 added.

EBL512 software version 2.1.1

- Chapter "DBI (Danish) convention", page 8.

### Revision 2

SW version 2.1.3.

Chapter 1.3

- The chapter is added.

Chapter 5.5

- Added information.

Chapter 13.5.1

- Added information for "19", "20" and "21".

Elucidation and small corrections:

Chapter 3.3.2

- Added information in paragraph 3).

Chapter 8

- Added information under "**NOTE!**"

Chapter 24

- Table updated.

Chapter 26.2

- Added footnote (Table / Programmable outputs)



This page has deliberately been left blank.



**Matsushita Electric Works Fire & Security Technology AB**

Citadellsvägen 23, SE-211 18 Malmö, Sweden

Tel.: +46(0)40 697 70 00 • Fax: +46(0)40 697 70 99

Internet: [www.mfstech.com](http://www.mfstech.com) • E-mail: [info@mfstech.com](mailto:info@mfstech.com)

**NAiS**