

Planning Instructions

MEW01351

Revision 2

Fire Alarm System EBL512 G3 V1.1.x

Author:	Jan Pettersson	Date of issue: 2011-07-01	Date of rev: 2012-05-24
---------	----------------	---------------------------	-------------------------

This page has deliberately been left blank.

Table of contents

1	Introduction	9
2	Definitions / Explanations	11
2.1	PESN AB	11
2.2	Alarm points	11
2.2.1	Smoke detector	11
2.2.2	Sensor	11
2.2.3	Analog detector	11
2.2.4	Analog (Sensor) Base (ASB)	11
2.2.5	Conventional detector	11
2.2.6	(Conventional Detector) Base (CDB)	11
2.2.7	Addressable	11
2.2.8	Conventional zone line input / External line	12
2.3	Output unit	12
2.4	Output / Control output	12
2.5	Short circuit isolator (ISO)	12
2.6	Display unit (D.U.)	12
2.7	COM loop	12
2.8	Control Unit / C.U. / C.I.E.	12
2.9	Fire Brigade Panel (FBP)	12
2.10	Control panel (CP)	12
2.11	System	12
2.12	Network / TLON [®] / LonWorks [®] / Echelon / Node / TLON Conn. board / Channel / Backbone net / Router / Repeater	13
2.13	LED	13
2.14	External Indicator (Ext. LED)	13
2.15	Display / LCD	13
2.16	Door open (Door / Key switch)	13
2.17	Site Specific Data (SSD)	14
2.18	Software (S/W) / Firmware / System program	14
3	Overview	15
3.1	The EBL512 G3 system	15
3.1.1	Printer	15
3.1.2	Expansion boards	15
3.1.3	Power supply	15
3.2	S/W versions	16
3.3	Documents	16
3.4	Applications	16
3.5	PC software (S/W)	16
3.5.1	WinG3	16
3.5.2	TLON Manager	17
3.5.3	WebG3 Config tool	17
4	Control Unit / TLON Network	18

4.1	The TLON network	18
4.2	Single TLON Network / Redundant TLON Network	18
5	Control Units 5000 and 5001	20
5.1	Mounting plates	22
5.1.1	Mounting plate for 19" mounting rack, 5020	22
5.1.2	Mounting plate for inflammable wall, 5021	22
5.2	COM loops	23
5.3	Programmable voltage outputs (S0-S3)	25
5.4	Programmable relay outputs (R0-R1)	25
5.5	Programmable inputs (I0-I3)	25
5.6	Relay outputs for routing equipment (tx)	26
5.6.1	Fire alarm output	26
5.6.2	Fault condition output	26
6	Expansion boards 458x	27
6.1	Expansion board no. (address) setting	28
6.2	8 zones expansion board 4580	28
6.2.1	Type of zone line input	28
6.2.2	Input states	29
6.3	8 relays expansion board 4581	30
6.4	Inputs and outputs expansion board 4583	30
6.5	I/O Matrix board 4582	32
6.5.1	Generic	33
6.5.2	Fan control	34
6.5.3	Zone control	34
7	Printer	35
8	TLON connection board 1590 / 5090	36
8.1	Single TLON Network	36
8.2	Redundant TLON network	36
8.3	Network programming	36
9	Peripheral devices	38
9.1	COM loop units	38
9.1.1	Input units	40
9.1.2	Addressable I/O units	47
9.1.3	Alarm devices (addressable sounders)	49
9.1.4	Short circuit isolators (addressable)	50
9.1.5	Units for Hazardous (Ex) areas	51
9.1.6	Other COM loop units	53
9.1.7	COM loop addresses for Base station and Wireless detectors	55
9.2	Units connected to the RS485 interface	55
9.2.1	External Fire Brigade Panels	56
9.2.2	Alert Annunciation Units	57
9.2.3	External Presentation Units	58
9.2.4	German Fire Brigade Panels	59
9.3	Units connected to the RS232 interface J7	60

9.3.1	Web-servers	60
9.4	Other units	60
9.4.1	Alert Annunciation Controllers	60
9.4.2	External LED	61
9.4.3	Alarm devices (sounders, etc.)	61
9.4.4	Door release magnets	61
9.4.5	Boxes	62
9.4.6	Duct detector chambers	62
10	Programmable inputs	63
10.1	Control unit Inputs I0 - I3 & Inputs 0 -4 on exp. board 4583	63
10.1.1	Not supervised	63
10.1.2	Supervised	63
10.2	The 3361 unit's Inputs In0 / Z & In1	64
10.2.1	Input In0	64
10.2.2	Input In1	64
11	Input programming	65
11.1	Trigger conditions	65
11.2	Logic	68
11.2.1	Supervised	68
12	Programmable outputs	69
12.1	Control unit outputs S0 – S3	70
12.2	Control unit outputs R0 & R1	70
12.3	8 relays expansion board 4581 Output 0 – Output 7	71
12.4	Inputs and Outputs expansion board 4583 Output 0 & Output 17	71
12.5	The 3361 unit's Outputs Re0 & Re1	71
12.6	The 3364 unit's VO0 – VO2	71
12.7	The 3377 unit's Output (siren)	72
12.8	The 3379 unit's Output (sounder)	72
12.9	The 4380 unit's Output (beacon)	72
13	Output programming	73
13.1	Type of output	73
13.2	Logic	74
13.3	Supervised / Not supervised	74
13.4	Output signal period	74
13.5	Control expression	77
13.5.1	Trigger conditions	77
13.5.2	Logical operators	82
13.5.3	Control expression examples	82
14	Interlocking function	86
14.1	Programming of interlocking function	86
14.1.1	Interlocking output	86
14.1.2	Interlocking input	86
14.1.3	Interlocking combination	86
14.2	Interlocking indications	88
14.3	Information of interlocking combinations (H9)	88

14.3.1	Display interlocking information (H9/C1)	88
14.3.2	Activate interlocking output (H9/C2)	89
14.3.3	Reset interlocking output (H9/C3)	89
14.3.4	Disable interlocking output (H9/C4)	89
14.3.5	Re-enable interlocking output (H9/C5)	89
14.4	Interlocking control expressions	89
15	Fire Door Closing	90
16	Functions / Services / Features	91
16.1	Sensor value	91
16.2	Week average sensor value	91
16.3	Decision value	92
16.4	Alarm algorithms for smoke detectors / Detection levels / Offsets	92
16.4.1	Alarm algorithm / Alternative alarm algorithm	93
16.4.2	Filtering algorithm	94
16.4.3	Smouldering smoke algorithm	96
16.5	Performance factor	97
16.6	Algorithms for analog heat detectors	98
16.6.1	Class A1 algorithm	99
16.6.2	Class A2 S algorithm	99
16.6.3	Class B S algorithm	99
16.7	Self verification	99
16.8	Minimum / Maximum sensor values	100
16.9	2-zone / 2-address dependence (Co-incident alarm)	101
16.9.1	2-zone dependence	101
16.9.2	2-address (-unit) dependence	102
16.9.3	Reset of 2-zone / 2-address dependence (co-incident alarm)	102
16.10	Delayed alarm	103
16.11	Selective Alarm Presentation	103
16.12	Alarm Verification Facility	103
16.13	Alert Annunciation	104
16.14	Alarm Acknowledgement Facility (AAF)	106
16.15	Quiet alarm	108
16.16	Fire alarm type A and Fire alarm type B	108
16.16.1	Fire alarm type B	109
16.16.2	Fire alarm type A	109
16.17	Disable alarm points and outputs	109
16.17.1	Disable zone	110
16.17.2	Disable zone / address	110
16.17.3	Disable control output	110
16.17.4	Disable / Re-enable output type	110
16.17.5	Disable / Re-enable alarm devices	110
16.18	Disable interlocking output	110
16.19	Disable outputs for routing equipment	110

16.20	Disconnect & Re-connect loop / zone line input	111
16.21	External time channels	111
16.22	Test mode	111
16.23	Test alarm devices	111
16.24	Test of routing equipment	112
16.25	Calibration of supervised outputs	112
16.26	Service signal	112
16.27	Fault signal (fault condition)	113
16.28	Alarm texts	113
16.28.1	Creating the alarm texts via WinG3	113
16.28.2	Downloading alarm texts to the DU:s 1728 / 1735 / 1736 and ext. FBP:s 1826 / 1828	115
16.29	Real time clock (RTC)	115
16.29.1	Daylight saving time	116
16.30	Loss of main power source	116
16.30.1	Fault: Loss of main power source	116
16.30.2	LCD backlight	116
16.31	Evacuate	116
16.32	WinG3 menu Tools	117
17	Special New Zealand functions	119
17.1	Alarm devices	119
17.1.1	Silence alarm devices (inside switch)	119
17.1.2	New Zealand FB Silence switch (outside switch)	119
17.2	Battery faults	121
17.2.1	FAULT: Battery	121
17.2.2	FAULT: Low battery capacity	121
17.3	Routing equipment isolate (disable)	121
17.4	Acknowledged alarm	121
18	Cyber sensor functions	123
18.1	Pulse up – down counter	124
18.1.1	Pulse up – down counter for smoke	124
18.1.2	Pulse up – down counter for temperature	124
18.1.3	Pulse up – down counter for smoke & temperature	124
18.2	Fire judgement	124
18.3	Alarm threshold levels	125
18.4	Learning function / Learning conditions	125
18.4.1	Learning conditions	125
18.5	Alarm delay time	127
18.6	Analog data output	128
18.7	Sensitivity compensation	128
18.8	Self diagnosis of internal devices	129
18.9	Address setting check	129
19	Control unit properties	130
19.1	Control unit properties dialog box	130
19.1.1	General Information	130

19.1.2	Peripherals	130
19.1.3	Misc.	130
19.2	WinG3 Control unit pop-up menu	131
19.2.1	Reset alarm counter	131
19.2.2	Software version	131
19.2.3	Upgrade number of alarm points	132
19.2.4	Show event log	132
19.2.5	Restart	132
19.2.6	Delete	133
19.2.7	Properties	133
20	System properties (settings)	134
20.1	System properties dialog box	134
20.1.1	Name	134
20.1.2	User definable text	134
20.1.3	System properties, Page 1	134
20.1.4	System properties, Page 2	136
20.2	Menu System	137
20.2.1	Properties	137
20.2.2	Time channels	137
20.2.3	Alarm algorithms	139
20.2.4	Output Signal Periods	141
20.2.5	National holidays	142
20.2.6	Two zone dependence	143
20.2.7	System information	144
20.2.8	Edit Alarm texts	144
20.2.9	Alarm points	144
21	Download SSD	146
21.1	Check Loop	146
21.2	Single Control Unit	146
21.3	Control Units in a TLON network	147
21.4	User definable text messages download	147
22	Download software (S/W)	148
22.1	Single control unit (c.i.e.)	148
22.2	Control Units in a TLON network	150
23	Compatibility	151
24	Cable types	152
24.1	TLON Network cables	152
24.2	COM loop cables	152
24.3	Ext. FBP / Display Units cables	152
24.4	Conventional zone line cables	152
24.5	Alarm device cables	153
24.6	Other cables	153
25	COM loop cable length	154
26	Current consumption	157

27	Power supply	161
27.1	Charger functions	162
27.1.1	Charging	162
27.1.2	Battery charging functions:	162
27.1.3	Security functions	162
27.2	Current consumption calculations	163
27.3	Rectifier (main power source)	164
27.4	Battery (second power source)	164
27.5	Fuses	165
27.6	Form / Table of current consumption	166
28	S/W versions	167
29	Technical data	168
30	Limitations	169
30.1	User definable texts	169
30.2	C.i.e. / System	169
31	National regulations	171
32	Drawings / connection diagrams	172
33	Revision history	173

Drawings according to the valid table of drawings.

1 Introduction

EBL512 G3 Planning Instructions is a document¹ intended to be used by planning engineers as well as service / commissioning engineers.

This document should be read in conjunction with the drawings according to the valid Table of drawings and the EBL512 G3 Operating Instructions MEW01349.

When planning a fire alarm installation the national regulations have to be obeyed. A lot of detector types can be used. Detector coverage area and detector placing in the room / building, etc. are matters for the planning engineers and are not described in this document.

Due to continual development and improvement, different S/W versions might be found. This document is valid for **S/W version 1.1.x**. On the date / revision date of the document **x = 1**.

Since the EBL512 G3 control unit (c.i.e.) is produced for many countries the look, the texts, the functions, etc. might vary.

Products

Consists of one or more parts (HW) according to a **Product Parts List**. A product has:

- a **type number**

5000 EBL512 G3 c.i.e. Configured for 128, 256 or 512 alarm points and with or without printer depending on article number.

5001 EBL512 G3 c.i.e. No front panel and no Plexiglas in the door. Configured for 128, 256 or 512 alarm points depending on the article number.

- an **article number** is often the same as the type no. but a country code can be added (e.g. **SE** for Sweden). If the letters **PRT** also are added in the article number the product comes with a printer. If digits are added to the article number they are showing the number of alarm points configured (e.g. 5000PRTSE-128).

- a **product name** (e.g. **EBL512 G3 CU, 128 alarm points, with printer**)

HW

A HW (e.g. a **printed circuit board**) has:

- a **type number** (e.g. **5010**)

- an **article number**, often the same as the type no. but sometimes a country code is added (e.g. 5010SE)

¹ File name: C:\Temp\Temp nr 2\MEW01351(Rev 2).doc

- a **product name** (e.g. **Main Board 128 alarm points**)
- a **p.c.b. number** (e.g. **9290-2B**) and can also have a configuration (e.g. **CFG: 2**) and a revision (e.g. **REV: 1**)
- sometimes a **S/W**

S/W

A S/W has:

- a **version number** (e.g. **V1.1.x**)
- sometimes additional information, such as **Convention** (different functions / facilities), **Language**, **Number of addresses**, etc.

PC S/W

A PC S/W is a program used for programming, commissioning, etc. (e.g. WinG3). It has a **version number** (e.g. **V1.1.x**).

2 Definitions / Explanations

Definitions / explanations / abbreviations / etc. frequently used or not explained elsewhere in the document.

2.1 PESN AB

Panasonic **Eco Solutions** Nordic AB

2.2 Alarm points

Units, which can generate a fire alarm (in the control unit), i.e. analog detectors (sensors), conventional detectors, manual call points, etc.

2.2.1 Smoke detector

Analog and conventional photoelectric (optical) smoke detectors are available.

2.2.2 Sensor

Sensor = Analog detector

2.2.3 Analog detector

Contains an A/D-converter. The Control Unit pick up the digital values ("sensor values") for each detector individually. All evaluations and "decisions" are then made in the c.i.e. Analog detectors are addressable – an address setting tool is used for detector types 430x.

An analog detector has to be plugged in an analog sensor base (**ASB**).

2.2.4 Analog (Sensor) Base (ASB)

An analog detector is plugged in an ASB, which is connected to a COM loop (see below).

2.2.5 Conventional detector

Detector with only two statuses, i.e. normal and fire alarm. The detector has a closing contact and a series alarm resistor. Normally plugged in a conventional detector base **CDB** (see below) connected to a conventional zone line input, with an end-of-line device. Some types (e.g. water proof types) are connected directly on zone line.

2.2.6 (Conventional Detector) Base (CDB)

A conventional detector is plugged in a CDB, connected to a conventional zone line input.

2.2.7 Addressable

A unit with a built-in address device, i.e. each unit is individually identified, handled and indicated in the c.i.e.

(The unit can be an I/O unit with a zone line input, to which one or more conventional "alarm points" can be connected.)

- 2.2.8 Conventional zone line input / External line**
Input intended for one or more conventional alarm points. End-of-line device in the last alarm point on the line.
- 2.3 Output unit**
Addressable unit with programmable control outputs. Connected to a COM loop (see below).
- 2.4 Output / Control output**
Defined or programmable function. Relay output or voltage output (supervised / monitored or not), in the c.i.e. or an output unit connected on a COM loop.
- 2.5 Short circuit isolator (ISO)**
Addressable unit for automatic disconnection of a part (segment) of a COM loop (see below) in case of short circuit on the loop. (According to EN54-2, one ISO is required per 32 alarm points.)
- 2.6 Display unit (D.U.)**
Addressable unit for fire alarm presentation (incl. user definable alarm text messages, if programmed).
- 2.7 COM loop**
Loop = a cable, with two wires, to which all the addressable units can be connected. Starts in the c.i.e. and it returns back to the c.i.e.
- 2.8 Control Unit / C.U. / C.I.E.**
Control Unit = Control and Indicating Equipment = Unit to which the alarm points are connected (via e.g. a COM loop). Indicates fire alarm, fault condition, etc. Fire Brigade Panel & Control Panel, i.e. the front, included or not included. Printer included or not included.
- 2.9 Fire Brigade Panel (FBP)**
Unit intended for fire alarm presentation, etc. for the fire brigade personnel. Can be a part of the control unit (a part of the front) or a separate unit (external FBP).

In the ext. FBP, a printer can be included or not included.
- 2.10 Control panel (CP)**
A part of the control unit (a part of the front), intended for the building occupier, service personnel, etc., to "communicate" with the control unit / system.
- 2.11 System**
One control unit or several control units connected via a TLON network (co-operating control units).
-

2.12 Network / TLON[®] / LonWorks[®] / Echelon / Node / TLON Conn. board / Channel / Backbone net / Router / Repeater

Brief explanations to the words/expressions to be found in connection with a "network". See also separate TLON Technical description.

TLON[®] = TeleLarm Local Operating Network = a LonWorks[®] - based network² for communication between several units/nodes. The protocol is called LonTalk and the transmission works with doubly-terminated bus topology (Echelon FTT-10). To connect a control unit to the network, a TLON connection board has to be plugged in the control unit. EBL512 G3 also supports redundant TLON system communication. In this case two TLON connection boards have to be plugged in each control unit.

A network can be one channel (FTT-10) or several channels, connected via routers. (In the TLON Network a sub net = a channel.)

Routers are also used to increase the maximum cable length, node to node, in a network.

Router or Repeater is the same type of unit (different configuration). All network programming (configuration) are made with the PC program "TLON Manager".

2.13 LED

LED (Light Emitting Diode) = Yellow, green or red optical indicator ("lamp").

2.14 External Indicator (Ext. LED)

A unit with an LED. Connected to an ASB, CDB or any detector with an output for an ext. LED. (In old installations also an ADB.)

Lit when the built-in LED in the detector / base is lit.

2.15 Display / LCD

LCD (Liquid Crystal Display) = Display (in the c.i.e. or Display unit) for presentation of fire alarms, fault messages, etc. In EBL512 G3 it is a graphical monochrome LCD (320 x 240 dots) with backlight.

2.16 Door open (Door / Key switch)

In EBL512 G3 there is a door switch, which is activated when the control unit's door is open. In the ext. FBP 1828 this door switch is replaced with a key switch.

An open door is indicated in the LCD (i.e. an "open door" icon).

² LonWorks[®] = A "summing-up-name" for the market of Echelon Corporation Inc. technology.

2.17 Site Specific Data (SSD)

The SSD is unique for each installation. All alarm points, presentation numbers, user definable alarm text messages, programmable outputs, etc. are created in the PC program **WinG3** and also downloaded in EBL512 G3 with **WinG3**.

2.18 Software (S/W) / Firmware / System program

The software (S/W) – also called Firmware and System program – makes the control unit (the microprocessor) work. It is factory downloaded but a new version can, via the PC program **WinG3**, be downloaded in EBL512 G3 on site.

3 Overview

3.1 The EBL512 G3 system

EBL512 G3 is a microprocessor controlled intelligent fire alarm system, intended for analog addressable smoke detectors, as well as conventional detectors and manual call points. Programmable control outputs and output units are available. Up to 1020 addresses (of which up to 512 can be alarm points) can be connected to each control unit (c.i.e.) - according to EN54-2.

EBL512 G3 is available in several types, versions and configurations. It can be connected to a TLON network, i.e. in a "system" with up to 30 control units. Each control unit has access to all information.

<i>Product type no.</i>	<i>Product name</i>
5000	EBL512 G3 c.i.e. With or without a printer. <u>With</u> front and display.
5001	EBL512 G3 c.i.e. <u>Without</u> front, display and printer. No door.

EBL512 G3 is designed according to the European standard EN54, part 2 and 4. The Swedish front conforms to SS3654.

3.1.1 Printer

The control unit EBL512 G3 type **5000** can be delivered with a printer ("PRN" included in the article number) or without a printer.³

In Ext. Fire Brigade Panel 1826 it is possible to mount an optional Printer 1835.

3.1.2 Expansion boards

In the control unit (c.i.e.) it is possible to mount up to six expansion boards. The following types are available:

<i>Product type no.</i>	<i>Product name</i>	<i>Note</i>
4580	8 zones expansion board	
4581	8 relay outputs expansion board	
4583	In- and outputs expansion board	

Regarding the expansion boards, see also chapter "Expansion boards 458x, page 27 and EBL512 G3 drawings.

3.1.3 Power supply

The main power source is a built-in switched power supply (rectifier) 5037. 230 V AC, 1.6 A / 24 V DC, 6.5 A.

The second power source is a backup battery (2 x 12 V). In the c.i.e.

³ Printer 5058 is a spare part for the c.i.e. type 5000 with a printer, i.e. it comes without a mounting frame etc.

is space for two 28 Ah batteries. Larger batteries (up to 65 Ah) have to be placed outside the c.i.e.

The batteries and the power supply are connected to the Main board (5010), which handles the charging of the batteries, etc. See chapter "Power supply", page 161 for more information.

3.2 S/W versions

Due to continual development and improvement, different S/W versions can be found. When installing a new control unit in a system with "older" control units, you might have to update the S/W in the old control units (or download an older version in the new control unit). **The same S/W version is required in all control units** in a TLON network.

3.3 Documents

The following documents are available:

- Planning Instructions (this doc.)
- Operating Instructions MEW01349
- Drawings

Normally, information found in one of the documents is not found in another document, i.e. the documents complement each other.

3.4 Applications

The EBL512 G3 system is intended for small, medium and large installations. The intelligent control units offer the system designer and end user a technically sophisticated range of facilities and functions. Programming (PC software WinG3 and TLON Manager) and commissioning of the control units / system is very easy.

Start with one control unit and then later when it is required, add more units. The TLON network makes it possible to install the control units in one building or in many buildings.

3.5 PC software (S/W)

The following PC software is used together with the EBL512 G3 system.

3.5.1 WinG3

WinG3 is used for programming and commissioning of one or more control units, i.e. to:

- create and download / make a backup of site specific data (SSD)
- download new software / settings / conventions / configurations / control unit & system properties / etc.
- create and download the user definable alarm text messages shown in the display in the control units / ext. FBPs and other Display Units.

WinG3 shall have the same version number as the EBL512 G3 software version number, e.g. **1.1.x** and **1.1.x** respectively. (x indicates only a small correction and is not required to be the same.) Old SSD files can be opened in a newer (higher) version of WinG3, saved, edited and thereafter downloaded to an EBL512 G3 with the corresponding version.

3.5.2 TLON Manager

TLON Manager is used for the TLON Network programming, i.e data / addresses / etc.

3.5.3 WebG3 Config tool

A PC tool, **WebG3 Config tool** is used for configuration of the Web-server II (1598).

4 Control Unit / TLON Network

See also chapter "TLON connection board 1590 / 5090", page 36.

4.1 The TLON network

An installation (a system) can be **one control unit (c.i.e.)** or up to **30 control units** connected in a **TLON Network**.

In a TLON Network each control unit works independent but has nevertheless total access to all information in the system.

NOTE!

In a system with two or more control units in a TLON Network, pay attention to the following:

- A zone **must not be distributed over the system**, i.e. all alarm points in a zone have to be connected to one c.i.e.
- When the "Fire door closing" function is used, the alarm points and their "belonging" output must be connected to the same c.i.e.
- When the interlocking function is used, the input, the output and the Interlocking Combination (area-point) must be in / connected to one c.i.e. An input and an output can only be used in one Interlocking combination.
- When the AAF function is used, all devices within the same AAF zone must be connected to the same c.i.e.

4.2 Single TLON Network / Redundant TLON Network

The EBL512 G3 system can be build up as a single TLON Network or a redundant TLON Network.

In the single TLON Network, one TLON connection board (1590 / 5090) has to be plugged in each control unit whereas in the redundant TLON Network, two TLON connection boards have to be plugged in each control unit.

In the single TLON Network, only one network is available (Network no. 0) but in the redundant TLON Network, two networks are available (Network no. 0 and Network no. 1).

The redundant TLON Network supports full functionality also in case of a network fault (i.e. open circuit or short circuit) in one of the TLON networks. A fault in one of the TLON Networks generates the following fault:

FAULT: Control unit xx has no contact with control unit xx, network x

Where network x = Network no. 0 or Network no. 1.

NOTE!

In a system where each control unit is independent of the other (i.e. each control unit works like a "standalone" control unit) a single TLON Network may be sufficient. To maintain security, in this case:

- All control units shall be of type 5000, i.e. including front panel.
- The alarm points and their "belonging" outputs shall be connected to the same control unit.
- If fire alarm routing equipment (Fire brigade tx) shall be used, each control unit in the system shall be able to activate a fire alarm routing equipment independent of the other control units.

In all other cases and for highest security, a redundant TLON Network shall be used.

(According to EN54-13, 4.3.1.2: *A single fault on a transmission path connecting one CIE to another CIE, shall not adversely affect the correct functioning of any part of the networked system.*)

5 Control Units 5000 and 5001

Two types of control units are available:

Type no.	Product	Front (FBP with display & CP)
5000	EBL512 G3 c.i.e. Expansion boards can be mounted (option). Configured for 128, 256 or 512 alarm points and with or without printer is depending on the article number.	Yes
5001	EBL512 G3 c.i.e. Expansion boards can be mounted (option). Configured for 128, 256 or 512 alarm points depending on the article number. Printer cannot be mounted.	No



Figure 1. Left: The EBL512 G3 Control Unit 5000, with printer. The look might vary according to configuration, etc. **Right:** The EBL512 G3 Control Unit 5001.

The control unit is housed in a grey metal cabinet. Depending on country, convention, configuration, etc. the look, language and functions might vary, as well as the max. number of alarm points (128, 256 or 512). In total, 1020 COM loop units (addresses) can always be used.

The door in type 5000 has a Plexiglas ahead of the front, see Figure 1 and Figure 2 respectively.

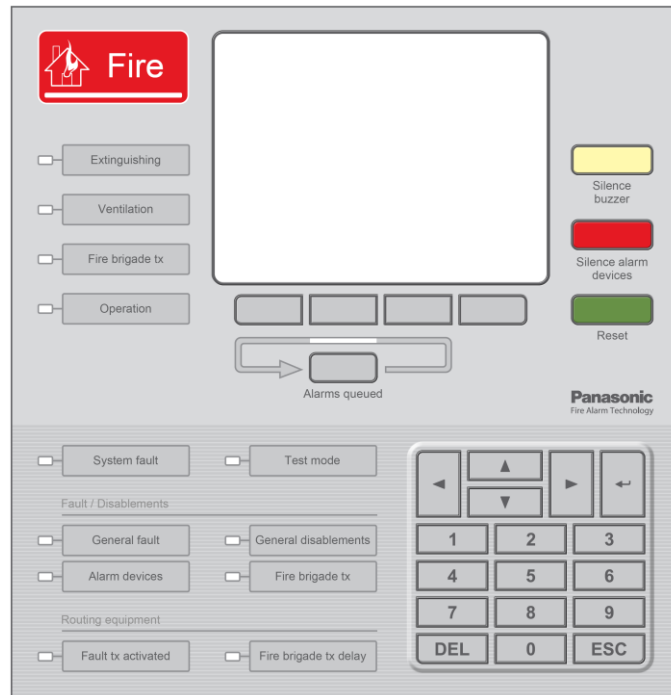

Figure 2. The EBL512 G3 front with display ("Man-Machine-Interface"); The Fire Brigade Panel (FBP) is the upper part and the Control Panel (CP) is the lower part. The look might vary depending on the language, country, etc. (A front with texts in English is shown in the figure).

The **FBP** is used by the fire brigade personnel to see which alarm point(s) / zone(s) having activated fire alarm and to take required operational control of the system. In the graphical display, the information displayed in the upper part is depending on how many alarm points / zones having activated fire alarm. In the middle part will the fire alarms be shown, i.e. one alarm point or one zone together with a user definable alarm text (if programmed) plus some other information.

External FBPs are also available.

The **CP** is to "communicate" with the system, i.e. for commissioning, monthly tests, maintenance, etc. Access codes for different access levels are required. A keypad is used to get access to the system (a menu tree with main and sub menus) and for operational control of the system. The CP has several system status LEDs.

NOTE! Regarding LED indicators, keypad / push buttons / soft keys, access levels and for more information, see EBL512 G3 Operating Instructions MEW01349.

Each control unit 5000-5001 has the following basic configuration:

- Grey metal cabinet
- MMI board (5011) (not in 5001)
 - EBL512 G3 front with display (not in 5001)
- Main board (5010)
 - Space & connectors for two TLON connection boards (1590 / 5090).
 - Four COM loops (0-3) to which the loop units are connected.
 - Four programmable supervised voltage outputs (S0-S3).
 - Two programmable relay outputs (R0-R1).
 - Four programmable inputs (I0-I3).
 - Six 24 V DC outputs (power supply outputs for Web-server II (1598), routing equipment and external equipment). Connections and more information, see dwg. 512 G3 - 22.
 - Two not programmable relay outputs for routing equipment (**Fire alarm** output for Fire brigade tx and **Fault condition** output for Fault tx). Connections and more information, see dwg. 512 G3 - 24.
 - Battery charger.
- Built-in power supply. See chapter "Power supply", page 161. Connections and more information, see dwg. 512 G3 - 21.
 - Switched power supply (rectifier), 230 V AC / 24 V DC (5037).
 - Space and connection cables for two Sealed Lead-Acid backup batteries (12 V, 28 Ah).
- Space for up to six expansion boards (458x).

See following chapters for more and detailed information.

5.1 Mounting plates

The 5000 and 5001 units are delivered with a mounting plate approved for mounting on an incombustible wall (e.g. concrete).

5.1.1 Mounting plate for 19" mounting rack, 5020

When the 5000 and 5001 units shall be mounted in a 19" mounting rack, the standard mounting plate can be replaced with a Mounting plate for 19" mounting rack 5020.

5.1.2 Mounting plate for inflammable wall, 5021

When the 5000 and 5001 units shall be mounted on an inflammable wall (e.g. wood), the standard mounting plate should be replaced with

a Mounting plate for inflammable wall 5021, which can be provided with cable glands.

5.2 COM loops

Each control unit has four COM loops (0-3) to which the loop units are connected. Connections according to dwg 512 G3 – 25, - 31, - 36, - 37 & - 38.

On each COM loop can up to 255 COM loop units be connected (COM loop address 001 – 255). Regarding type and number of COM loop units in relation to the cable length / type, see dwg 512 G3 – 41 and chapters "COM loop cable length", page 154 and "Current consumption", page 157.

NOTE! In total, up to 1020 (4 x 255) COM loop units can be used but only 512 can be alarm points, according to EN54-2.

Each COM loop unit has a COM loop address (e.g. 123) and depending on the loop number (e.g. 0) and the control unit number (e.g. 04) each COM loop unit gets a technical number (040123). Each alarm point and zone line input has a fire alarm presentation number (Zone-Address), e.g. 001-01. See EBL512 G3 Operating Instructions MEW01349 for more information.

Normally the control unit communicates with the COM loop units in the COM loop A-direction only. In the B-direction is only the COM loop voltage checked, which has to be ≥ 12 V DC.

A break or short circuit on a COM loop has to generate a fault in the control unit within 60-100 seconds (EN54-2 requirement).

If one or more Addressable short circuit isolators (4313) are used⁴, the loop will be divided into "segments" (i.e. the part between two short circuit isolators or between the control unit and one short circuit isolator). Only the affected segment will be isolated, which will minimise the number of units disabled by a short circuit.

The fault messages will also show between which isolators the short circuit or the break is situated.

If no addressable short circuit isolator (4313) are used, the whole COM loop will be disabled in case of short circuit on the loop.

COM loop return voltage <12 V DC or COM loop break(s) or COM loop short circuit:

This will start a "cycle" as follows.

⁴ One short circuit isolator per 32 alarm points is required according to EN54-2.

- The whole loop will be disabled, i.e. no voltage on the loop which means that the relay in all isolators will be powerless, i.e. there will be a “break” on the L (SA) wire in each isolator.

- The control unit (an algorithm) will now try to re-enable the first isolator (sequence no. 0) in the A-direction. If this is possible the next isolator (sequence no. 1 in the A-direction) will be re-enabled, if this is possible. And so on. The isolator just before a short circuit cannot be re-enabled.

- The control unit will now try to re-enable the first isolator (sequence no. ?) in the B-direction. If this is possible, the next isolator, and so on.

- Finally all isolators will be re-enabled except the isolator on each side of a short circuit and any isolator(s) between two or more breaks on the loop.

- Communication will be in both directions for 10 minutes. Then a new “cycle” starts.

- If the “fault(s)” are corrected, the communication will return to be in the A-direction only, else the communication will be in both directions for another 10 minutes when a new “cycle” starts, and so on.

Depending on if it is too low voltage on the loop, short circuit, one break or two or more breaks, the fault messages will be different.

- **FAULT: Cut-off loop x, control unit xx SCI nn <-> SCI nn**

NOTE! nn = A, 00, 01, 02, 03, 04, 05, 06, 07, 08, 09, 10, 11, 12, 13, 14, 15 or B.

- **FAULT: Short circuit loop x, control unit xxSCI nn <-> SC**

NOTE! nn = A, 00, 01, 02, 03, 04, 05, 06, 07, 08, 09, 10, 11, 12, 13, 14, 15 or B.

If there are multiple loop faults, i.e. one or more short circuits and/or one or more Cut-offs, there will be a “multiple COM loop fault” message.

- **FAULT: Multiple faults, COM loop x, control unit xx**

The first fault message will show the first fault in the A-direction.

There will always be a “no reply” message for all units not found in spite of communication in both directions.

- **FAULT: No reply zone: xxx address xx technical number xxxxxx**

Regarding Fault acknowledge, see the EBL512 G3 Operating Instructions MEW01349.

5.3 Programmable voltage outputs (S0-S3)

The 24 V DC outputs S0-S3 are supervised (monitored)⁵. Connections according to dwg 512 G3 – 23. When all connections are done a calibration has to be performed, see chapter "Calibration of supervised outputs", page 112 and the EBL512 G3 Operating Instructions MEW01349, chapter "Calibration of supervised outputs (menu H5/A1)".

Each output has to be programmed (via WinG3) regarding:

- Type of output, i.e. output for Control, Alarm devices, etc.
- Logic, i.e. normally low (default) **or** normally high (24 V DC)⁶.
- Activation time and type (steady, pulse, delay, etc.).
- Control expression (one or more trigger conditions).

See also the WinG3 help and chapter "Programmable outputs", page 69.

5.4 Programmable relay outputs (R0-R1)

Connections according to dwg 512 G3 – 23.

Each output has to be programmed (via WinG3) regarding:

- Type of output, i.e. output for Control, Alarm devices, etc.
- Logic, i.e. normally open (NO) **or** normally closed (NC) contacts.
- Activation time and type (steady, pulse, delay, etc.).
- Control expression (one or more trigger conditions).

See also the WinG3 help and chapter "Programmable outputs", page 69.

5.5 Programmable inputs (I0-I3)

Connections according to dwg 512 G3 – 23.

Each input has to be programmed (via WinG3) regarding:

- Trigger condition (Triggered by).
- Logic, i.e. normally open (NO) **or** normally closed (NC) contacts.
- Additional information, depending on the selected trigger condition (Fault no., Zone, Address, Fault message (Error text), etc.).

Open = $R > 20K$. Closed = $R < 500 \Omega$.

An input has to be activated ≥ 0.5 sec.

See also the WinG3 help and chapter "Programmable inputs", page 63.

⁵ The outputs are in WinG3 default set as supervised but via WinG3 it is possible to set each output (S0-S3) individually to be not supervised.

⁶ A normally high output is not supervised.

5.6 Relay outputs for routing equipment (tx)

Not programmable outputs. The outputs can be tested via menu H1, see the EBL512 G3 Operating Instructions MEW01349. Connections according to dwg 512 G3 – 24.

5.6.1 Fire alarm output

This output is normally used for fire alarm routing equipment (Fire brigade tx). It is a change-over relay contact that will be activated when a fire alarm is generated in the system⁷. Activated output is (normally) indicated by the LED "Fire brigade tx".⁸

5.6.2 Fault condition output

This output is normally used for fault warning routing equipment (Fault tx). It is a change-over relay contact that is normally activated and will be de-activated in case of a fault⁹ in the control unit (c.i.e.)¹⁰. De-activated output (i.e. fault condition) is indicated by the LED **Routing equipment** "Fault tx activated".

⁷ The output can be disabled via "door open" or via menu H2/B9. See also chapter "Alert Annunciation", page 104.

⁸ This output and programmable outputs with type of output = Fire brigade tx, will normally turn on the LED but a programmable input with trigger condition = Activated routing equipment, can turn on the LED instead.

⁹ Also when the control unit is out of power (i.e. power supply and battery out of work) or Watch-dog fault.

¹⁰ The output can be disabled via "door open" or via menu H2/B9.

6 Expansion boards 458x

Inside EBL512 G3 (5000 and 5001) there are space and holders for up to six optional expansion boards of the types **4580, 4581 and 4583** to be mounted, see drawing 512 G3 - 01. A ribbon cable **5089** shall be used for connection of up to six expansion board(s) to the main board. (Connector "J2" on the expansion board respectively and "J9" on the main board 5010.) See drawing 512 G3 - 26.

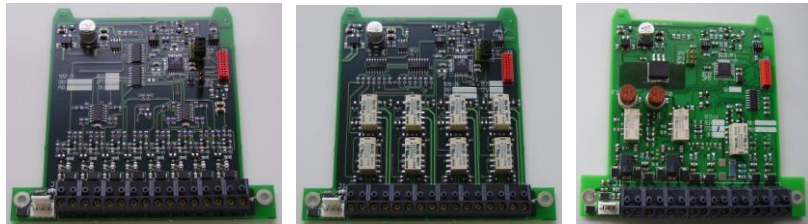

Figure 3. 8 zones expansion board 4580, 8 relays expansion board 4581 and In- and outputs expansion board 4583.

I/O Matrix board 4582¹¹ is a special type of "expansion board", plugged as a "piggy back" to an **Application board¹¹**, which is connected to a COM loop and to 24 V DC. On each COM loop 0-3 can up to six 4582 boards be used (i.e. up to 24 boards in total).

NOTE! COM loop 0 is however a special loop, since the exp. boards 4580, 4581 and 4583 actually are internally connected on this loop, i.e. on COM loop 0 can in total up to six 4580, 4581, 4583 and 4582 boards be used. This means that for each exp. board 4580, 4581 and 4583 used, the number of 4582 boards is reduced with one.



Figure 4. I/O Matrix board 4582.

Max. six of the I/O Matrix boards 4582 can be programmed as type Generic and/or Zone control.

NOTE! ≤ 512 programmable outputs per c.i.e. can be used.

Each expansion board 4580, 4581 & 4583 and the I/O Matrix board 4582 have to have a board address (board no. 0-5) set via jumpers on the board respectively. On boards of type 4580, 4581 and 4583 jumpers "JP2-JP4" and on board type 4582 jumpers "JP1-JP3", see Figure 5, page 28. All the board programming is done via WinG3.

¹¹ The 4582 board can be programmed as type Fan, Generic or Zone control. It is mostly used with Australian Application boards but the General I/O application board 4596 and Fan control application board 4594 (used with the Fan control panel 4593) are available on all markets, see page 54.

6.1 Expansion board no. (address) setting

The expansion board no. (address) is set via jumpers on the expansion board respectively.

Board no. (address)	4580, 4581 and 4583			4582		
	JP2	JP3	JP4	JP1	JP2	JP3
0	Open	Open	Open	Open	Open	Open
1	Shunted	Open	Open	Shunted	Open	Open
2	Open	Shunted	Open	Open	Shunted	Open
3	Shunted	Shunted	Open	Shunted	Shunted	Open
4	Open	Open	Shunted	Open	Open	Shunted
5	Shunted	Open	Shunted	Shunted	Open	Shunted

Figure 5. Expansion boards 4580 - 4583. Jumpers for expansion board no. (address) setting.

6.2 8 zones expansion board 4580

Each board has to be programmed via WinG3 regarding:

- Address / Board no. (set via the jumpers "JP2-JP4", see Figure 5 above.)

The 4580 board has eight conventional zone line inputs (0-7) intended for conventional detectors. In the last alarm point on each zone line, has to be connected an end-of-line device, depending on the selected "Type of zone line input", see below.

Connections to "J1:1-16" and "J2" according to drawing 512 G3 - 33.

Each zone line input has to be programmed via WinG3 regarding:

- Type of zone line input (see below), depending on detectors / end-of-line device (capacitor or resistor), i.e. different threshold levels etc.
- Alarm at short circuit / No alarm at short circuit (i.e. if short-circuit on the zone line shall generate a fire alarm or a fault)
- Zone number (address optional)
- Fire alarm delay / No fire alarm delay
- Text (Alarm text – if you wish)
- Alert annunciation & time channel
- Disablement & time channel

The terminals support a wire size up to 1.13 mm² (1.2 mm).

6.2.1 Type of zone line input

Each input shall be selected as **Not used** or one of the following types / modes.

6.2.1.1 Zone line input (EOL capacitor)

This type is normally used. It has the lowest zone line current consumption since the end-of-line device is a capacitor, 470 nF ($\pm 10\%$). Max. allowed cable resistance is 50 ohm. Max. allowed cable capacitance is 50 nF. Total detector current consumption ≤ 1.5 mA.

6.2.1.2 EX zone line input (EOL resistor)

This type shall be used **only** when units for Hazardous (Ex) areas shall be connected, i.e. via the Galvanic isolator MTL5061 (2820). The end-of-line device has to be a resistor, 10K ($\pm 5\%$) with a body surface area > 230 mm² (supplied with the Galvanic isolator). Max. allowed cable resistance is 40 ohm. Max. allowed cable capacitance is 70 nF. Total detector current consumption ≤ 1.0 mA.

6.2.1.3 Zone line input (EOL resistor)

NOTE! Valid for the Australian and New Zealand conventions only.

This type shall be used **only** when any of the other types cannot be used (e.g. for some older type of detectors and not Panasonic detectors). It has the highest zone line current consumption since the end-of-line device is a resistor, 4K7 ($\pm 5\%$). Max. allowed cable resistance is 50 ohm. Total detector current consumption ≤ 2.0 mA.

6.2.2 Input states

Each input will be in one of six different states.

6.2.2.1 Normal state

The normal zone line input state, i.e. no alarm, no fault, etc. and the nominal voltage is 24 V DC¹². From this state any other state can be reached / activated.

6.2.2.2 High current state

The max. current consumption limit¹³ for the zone line input is exceeded, which is indicating that e.g. too many detectors are connected. This generates a fault condition in EBL512 G3. From this state any other state can be reached / activated except the open circuit state.

6.2.2.3 Alarm state

One alarm point (or more) on the zone line is in alarm state and the alarm limit¹³ for the zone line is exceeded. This activates a fire alarm in EBL512 G3. In this state short-circuit, open circuit, high current and low voltage states cannot be reached / activated. After alarm reset (in EBL512 G3) the zone line input will return to the normal state.

¹² Allowed voltage 15-28 V DC.

¹³ This limit is depending on the selected input mode.

6.2.2.4 **Short-circuit state**

The short-circuit current limit¹³ is exceeded, indicating short-circuit on the zone line. This normally generates a fault condition in EBL512 G3 **but** instead a fire alarm can be activated, if this option is selected via WinG3.

6.2.2.5 **Open circuit state**

The open circuit current limit¹³ is passed, indicating no or too low zone line current consumption, i.e. the end-of-line device is not detected. This generates a fault condition in EBL512 G3. From this state any other state can be reached / activated.

6.2.2.6 **Disconnected state**

Via menu H8/S1 (Disconnect loop / zone line input) the zone line input can be disconnected¹⁴, i.e. there is no voltage on the zone line. From this state no other state can be reached / activated.

6.3 **8 relays expansion board 4581**

Each board has to be programmed via WinG3 regarding:

- Address / Board no. (set via the jumpers "JP2-JP4", see Figure 5, page 28.

The 4581 board has eight programmable relay outputs (Output 0-7). Connections to "J1:1-16" and "J2" according to drawing 512 G3 - 34.

Each output has to be programmed via WinG3 regarding:

- Type of output, i.e. output for Control, Alarm devices, etc.
- Output signal period (steady, pulse, delay, etc.)
- Logic, i.e. normally open (NO) **or** normally closed (NC) contacts¹⁵
- Control expression (one or more trigger conditions)

For more information, see the WinG3 help and chapter "Programmable outputs", page 69.

The terminals support a wire size up to 1.13 mm² (1.2 mm).

6.4 **Inputs and outputs expansion board 4583**

Each board has to be programmed via WinG3 regarding:

- Address / Board no. (set via the jumpers "JP2-JP4", see Figure 5, page 28.

The I/O expansion board 4583 has two programmable supervised / not supervised voltage outputs (Output 0-1), one special / programmable

¹⁴ This is indicated in EBL512 G3 by the LED **Fault / Disablements** "General disablements".

¹⁵ Relay contact ratings: Max. 2A @ 30 V DC.

output (Output 2) intended for German extinguishing system and five programmable supervised / not supervised inputs (Input 0-4). Connections to "J1:1-16" and "J2" according to drawing 512 G3 – 35, sheet 1/2 and sheet 2/2.

Output 0-1 has to be programmed via WinG3 regarding:

- Type of output, i.e. output for Control, Alarm devices, etc.
- Output signal period (steady, pulse, delay, etc.)
- Supervised / Not supervised¹⁶
- Logic, i.e. normally low (default) **or** normally high (24 V DC)¹⁷.
- Control expression (one or more trigger conditions)

One to five 33K resistors can be connected. When the connections are finished, a calibration has to be done. Calibration value has to be in the range 4K7-50K. See also the EBL512 G3 Operating Instructions MEW01349 chapter "Calibration of supervised outputs (menu H5/A1)".

Voltage **Output 0** (J1:1-2): Max. 200 mA (Fuse F1). Can be used for German fire alarm routing equipment, fire alarm. ("*E*" *Brandmeldung*)

Voltage **Output 1** (J1:5-6): Max. 200 mA (Fuse F2). Can be used for German fire protection equipment / key cabinet. ("*G*" *FSK öffnen*)

See also the WinG3 help or chapter "Programmable outputs", page 69.

Output 2 has to be programmed via WinG3 regarding:

- Type of output, i.e. output for Control, Alarm devices, etc.
- Output signal period (steady, pulse, delay, etc.)
- Logic, i.e. normally open (default) **or** normally closed.
- Control expression (one or more trigger conditions)

Output 2 (J1:11-12): Normally open (high resistance, 3K3, when supervised) or Normally closed (low resistance, 680R, when supervised). Used for German extinguishing system (*Löschanlage*).

See also the WinG3 help or chapter "Programmable outputs", page 69.

Input 0-4 have to be programmed via WinG3 regarding:

- Trigger condition (Triggered by)
- Supervised / Not supervised
- Logic, i.e. Normally open (high resistance, 3K3, when supervised) **or** Normally closed (low resistance, 680R, when supervised)
- Additional information depending on the selected type

Input 0 (J1:3-4): Can be used for German Fire alarm routing equipment fault (*Melder quittung*)

Input 1 (J1:7-8): Can be used for German key cabinet (*FSK*)

¹⁶ A normally high output can not be supervised. The supervision voltage is 1.5 – 3.6 V DC (depending on the number of supervision resistors) and the polarity is reversed compared to an activated output.

¹⁷ Regarding the **system voltage**, see chapter "Power supply", page 161.

rückmeldung)

Input 2 (J1:9-10): Can be used for German key cabinet (*FSK überwachung*)

Input 3 (J1:13-14): Can be used for German extinguishing system (*Löschanlage ausgelöst*)

Input 4 (J1:15-16): Can be used for German extinguishing system (*Löschanlage quittung*)

See also the WinG3 help or chapter "Programmable inputs", page 63.

6.5 I/O Matrix board 4582

A special type of expansion board that only can be used together with an **Application board** (e.g. Fan, Generic or Zone), see pages 27 and 54. The I/O Matrix board makes it possible for any retailer to manufacture and connect three different types of "Application boards" to EBL512 G3 via the COM loop.

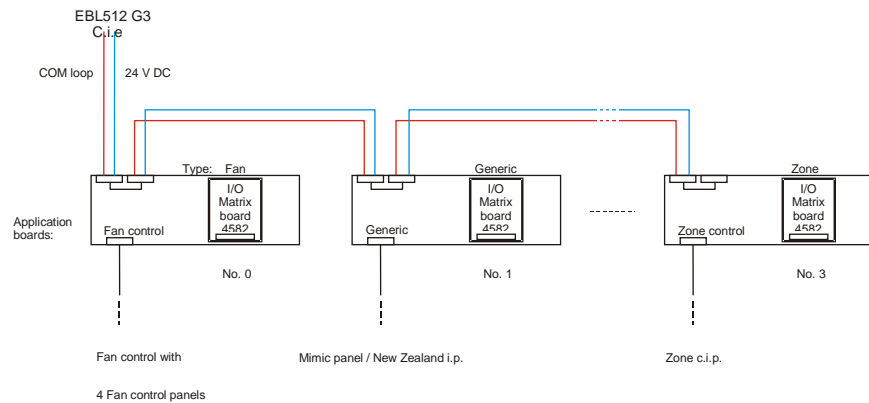

Figure 6. I/O Matrix board application overview. The COM loop and 24 V DC are internally connected to the I/O Matrix board.

The I/O Matrix board (80 x 63 mm) is plugged to the Application board respectively ("piggy back" connection) and has 16 switch inputs and 48 LED outputs. The COM loop and 24 V DC is connected to the Application board.

Three different **application board types** can be selected via jumpers (**JP4-JP5**) on the I/O Matrix board:

Generic control and indicating panel (Mimic panel alt. New Zealand indication panel), with 16 inputs (any input trigger condition can be used) and 48 outputs (any output trigger condition can be used).

This type is used with the "General I/O application board" 4596.

Fan control and indicating panel, for four Fan control panels, each with six LEDs (On / Auto / Off / Running / Stopped / Fault) and three push buttons (On / Auto / Off). One "Reset" switch.

Simple or Advanced function for a "Supply air fan" or a "Standard

fan". Enhanced function for a "Smoke exhaust", "Smoke spill", "Stair pressurisation" or a "Supply air" fan.

This type is used with the "Fan control application board" 4594.

Zone control and indicating panel, with outputs and inputs for 16 zone LEDs (Alarm / Fault / Disabled) and 16 push buttons (Disable).

For the number and type of boards that can be used, see page 27.

There is no COM loop address to be set. Instead, the **expansion board no. / address** (0-7) is set with jumpers (**JP1-JP3**) on the I/O Matrix board respectively. See Figure 5, page 28.

In EBL512 G3 can totally up to 512 outputs be used, including all kinds of outputs.

For more information (e.g. application board type selected via jumpers JP4-JP5), see the I/O Matrix board 4582, Technical description MEW00914.

Each I/O Matrix board has to be added via WinG3

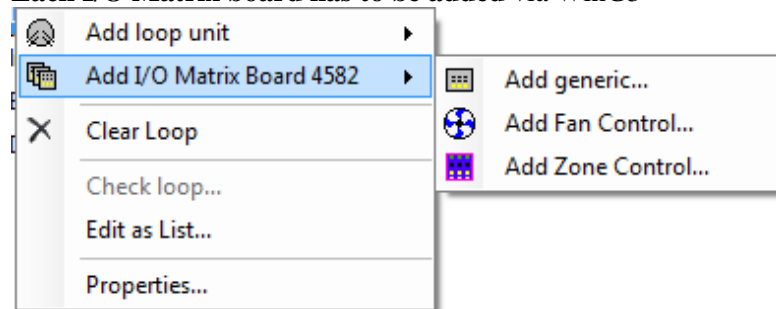

....and **programmed** regarding:

- **Address** (shall be the same board no. as set via jumpers "JP1-JP3"), see Figure 5, page 28.
- **Name** (I/O Matrix Board # - normally not changed)
- **LED test on Input 15** (selected or not selected)

The 4582 board has 48 LED outputs and 16 switch inputs (0-15). Depending on the type (Generic, Fan or Zone), the outputs and inputs are programmed differently.

Available application boards (fan control and general I/O boards), see page 54.

6.5.1

Generic

Used for Application board type **Generic**, e.g. "General I/O application board" 4596 (see page 54).

Each output (0-47) has to be added and programmed via WinG3 regarding:

- Output no. (0-47)
- Properties, like any programmable relay output.

Each input (0-15) has to be added and programmed via WinG3 regarding:

- Input no. (0-15)
- Type (of input)
- Properties, like any programmable input.

6.5.2

Fan control

Used for Application board type **Fan control**, e.g. "Fan control application board" 4594, which has a front for Fan control of up to four fans.



Fan control panel 4593 has two Fan control application boards 4594 and two Fan control fronts (see page 54).

Each Fan (0-3) (i.e. each Fan control) **has to be added and programmed** via WinG3.

For each fan (Fan control), also one **I/O unit for fan control 3361** (COM loop unit) has to be added and programmed via WinG3 regarding e.g:

- Technical address (COM loop address 1-255)
- Name (Fan control I/O unit - normally not changed)
- Fan control information
 - I/O Matrix fan control (Fan control / fan 0-3)
 - Supervised **or** not supervised (Input In0)
 - Output latched **or** not latched
 - Enhanced fan control function **or** not.
 - Fault detection time (Input In0; 30-255 seconds)
- Properties, like any programmable output.
- Normally stopped **or** Normally running

6.5.3

Zone control

Used for Application board type **Zone control**.¹⁸

Each input (0-15) has to be programmed via WinG3 regarding:

- Zone (control) no. (0-15)

¹⁸ Zone control is normally used on the Australian market only.

7 Printer

The control unit type **5000** can be with or without a printer depending on if "PRN" is added in the article number or not. It is mounted on the front panel door and is connected to the MMI board 5011. See drawing 512 G3 – 01, sheet 2/2.

When the printer is mounted, the checkbox "Printer" has to be marked in the WinG3 "Control unit properties" dialog box.

The following will / can be printed:

- Alarms (Fire alarms – incl. test mode alarms & Heavy smoke / heat alarms, etc.)
- Disablements, etc. via menus H4/U1 – U2
- Detectors activating service signal via menu H4/U5
- The event log via menu H4/U6
- The control unit configuration via menu H4/U7
- Activated Interlocking inputs via menu H9/C1

The printer only – not the mounting frame - is available as a spare part, type number 5058.

8 TLON connection board 1590 / 5090

On the EBL512 G3 control unit (5000 / 5001) main board (5010), there are spaces and connectors for two TLON connection boards type 1590 / 5090¹⁹. In a single (standalone) control unit there shall be **no** TLON connection board mounted.

A system, with two or more control units, uses a **single TLON Network** or a **redundant TLON Network**, see below.

The TLON connection boards are mounted on the main board (5010) according to dwg. 512 G3 – 11 and the networks are connected to the terminal block "J4" on main board according to dwg 512 G3 - 24.

8.1 Single TLON Network

In a single TLON Network (Network no. 0), the TLON connection board (1590 / 5090) shall be mounted in position no. 0 on the main board. A single TLON Network is a violation to the EN54-13 standard.

8.2 Redundant TLON network

In a redundant TLON Network (Network no. 0 and no. 1), the TLON connection boards (1590 / 5090) shall be mounted in position no. 0 and position no. 1 on the main board.

Normally only Network no. 0 will be in use and in case of a network fault (i.e. open circuit or short circuit), Network no. 1 will be automatically used until there is no fault on Network no. 0.

See also chapter "Control Unit / TLON Network", page 18.

8.3 Network programming

The PC program **TLON Manager** is used for the TLON Network programming. **TLON Manager V1.X** will be replaced by **TLON Manager V2.0**.

In a redundant network two Projects have to be created and installed. The Projects have to be identical but with different Project names. One has to be installed for Network no. 0 and one installed for Network no. 1.

NOTE! By the TLON Network programming (installation), some unique data will be stored in a TLON connection board (1590 / 5090) memory and some unique data will be stored in a main board (5010) memory.

¹⁹ TLON connection board type 1590 will be replaced with the next generation TLON connection board 5090.

After replacing a TLON connection board to another (or replacing both a TLON connection board and a main board), do "Replace" and "Update" in TLON Manager.

After replacing a main board to another (i.e. not the TLON connection board), do "Update" in TLON Manager.

9 Peripheral devices

Alarm points. **Analog** alarm points (detectors, etc.) are connected directly to a COM loop. **Conventional** alarm points (detectors, etc.) are connected to an 8 zones expansion board (4580) zone line input or a COM loop unit (e.g. 3361) zone line input. Programmable inputs can also be used for flow switches etc.

Short circuit isolators can be used on the COM loops.

Sounders, door release magnets, etc. are connected to COM loop unit (e.g. 3361 / 3364) outputs and/or control unit outputs (S0-S3, R0-R1) and/or 8 relays expansion board (4581) outputs. Addressable sounders (3377 / 3379) are connected directly to a COM loop.

Input devices as key cabinet, timers, external faults, etc. are connected to a programmable input, i.e. to COM loop unit (e.g. 3361) inputs and/or to the control unit inputs (I0-I3).

Routing equipment is normally connected to the control unit outputs "Fire alarm" (for Fire brigade tx) and "Fault condition" (for Fault tx). (Also, any programmable output can be used).

External Fire Brigade Panels and External Displays Units are connected directly to the RS485 channel.

As an **alternative** the RS485 channel can be used for:

German Fire Brigade Control Panel (FBF) and German Fire Brigade Indicator Panel (FAT).²⁰

More information, see the Product Leaflet for the device respectively.

9.1 COM loop units

















Each COM loop (0-3) can handle up to 255 addressable COM loop units, i.e. in total up to 1020 COM loop units, of which max. 512 can be alarm points. Depending on the type of units and the number of units the total current consumption will vary and this will affect the cable length. See chapters "COM loop cable length", page 154, "Current consumption", page 157 and dwg 512 G3 - 41.

NOTE! The control unit can be configured for up to 128, 256 or 512 alarm points. Normally this is factory set but can be changed on site (via WinG3)²¹. In menu H4/U7 is the current configuration shown. The units should be distributed as even as possible on each COM loop and between the COM loops (0, 1, 2 & 3). **Up to 1020 units can be used but max. 512 of these can be alarm points, according to EN54-2.**

²⁰ If **German panels** are connected to the RS485 channel, **no other units** can be connected to the RS485 channel.

²¹ This action require a special download password.

The following units can be connected to the COM loops (in **NORMAL** mode):

	OPT Analog Photoelectric Smoke Detector (4301)...	Ctrl+1
	AHD Analog Heat Detector (3308, 3309)...	Ctrl+2
	AMD Analog Multi Detector (4300)...	Ctrl+3
	MCP Addressable Manual Call Point (3333)...	Ctrl+4
	I/O Unit (3361)...	Ctrl+5
	I/O Unit for Fan control 3361...	Ctrl+6
	ASI Addressable Siren (3377)...	Ctrl+7
	ASB Addressable Sounder Base (3379)...	Ctrl+8
	AOU Addressable two voltage output unit (3364)...	Ctrl+9
	EPS Addressable External Powersupply (3366)...	Ctrl+0
	SCI Short Circuit Isolator (4313)	Ctrl+E
	Alarm Acknowledge Facility Control (AAFC)...	Ctrl+G
	Addressable beacon 4380...	Ctrl+H
	MCP Addressable Manual Call Point with Isolator 4333...	Ctrl+I
	Addressable base station for wireless units 4610...	Ctrl+J
	Wireless photoelectric smoke detector 4601...	Ctrl+K
	Obsolete loop units	





NOTE!

The **Alarm Acknowledge Facility Control (AAFC)** is used on the Australian market only.

The **I/O Unit for Fan control (3361)** is normally used with the Fan control panel 4593 only.

The **MCP Addressable Manual Call Point with Isolator 4333** is a future product under construction, i.e. cannot be used today.

Obsolete units (listed below) can be found in old installations and can be used in EBL512 G3 installations as well.

	ZI1 Addressable Zone Interface (2226/2335/2821)...
	MCP Addressable Manual Call Point (2333)...
	AHD Addressable Heat Detector (2340, 2341)...
	Analog ionization smoke detector 2300...
	Analog photo electric smoke detector 2304...

NOTE!

When one or more of the **Obsolete units** listed above are used on a COM loop, the maximum number of loop units is 127, i.e. only technical address **1-127** can be used.

Address setting

Each COM loop unit has to have a unique COM loop address (001-255). This address and the mode are set with an Address Setting Tool (3314). For **EBL512 G3** is always the **NORMAL** mode used (default).

NOTE! The COM loop address for the Addressable Base station for wireless units (4610) is set on a DIL-switch in the unit respectively. The COM loop address for a wireless detector (4601) is depending on which Base station it is "connected" to, see chapter "Other COM loop units", page 53.

9.1.1 Input units

Each COM loop input unit is added and programmed via WinG3. Depending on type of unit, regarding:

- Technical address (COM loop address) 001-255
- Name (normally not changed)
- Zone number and Address within the zone
- Alarm text (user definable)
- Regular Alarm algorithm (some units only)
- Options:
 - Alternative Alarm algorithm & Time Channel (some units only)
 - Alert annunciation & Time Channel (some units only)
 - Disablement & Time Channel (some units only)
 - Two-units-dependent fire alarm, i.e. co-incidence alarm & Time Channel (some units only)
 - Delayed (fire alarm)
 - Quiet alarm (Australian function)

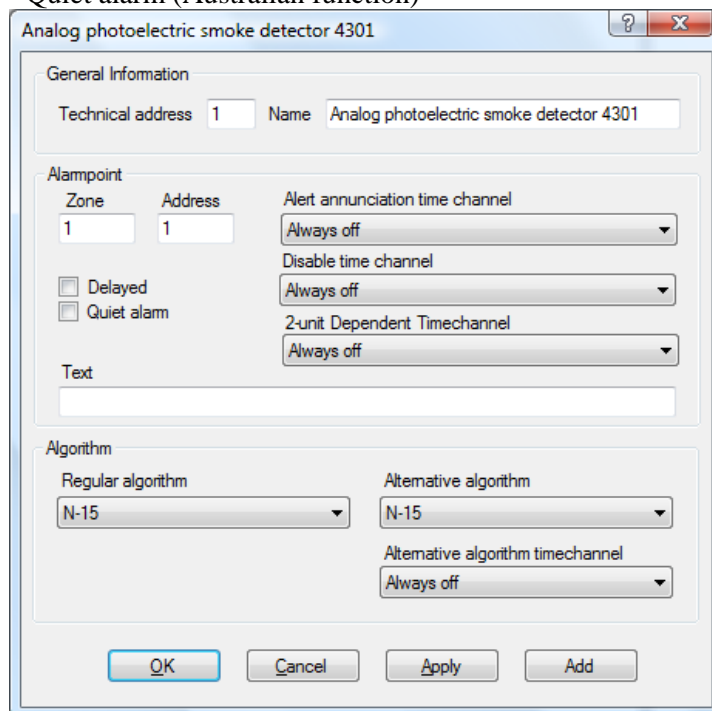

Figure 7. An **example** of a WinG3 dialog box is the "Analog photo electric smoke detector 4301" dialog box.

Connections, if nothing else is specified, see drawing 512 G3 - 31.

9.1.1.1

Analog Sensor Bases (ASB)

An analog detector (Sensor) shall be plugged in an analog base. The COM loop address is set in the detector, see below.



3312 Analog Base.²² 3312 has screw terminals for the COM loop and an ext. LED (2218). Prepared for mechanical lock of the detector - if required. Recess for label holder (3391). The base has an address label on which the plugged-in detector's COM loop address can be written.



3312FL Analog Base. Like 3312 but instead of screw terminals for the COM loop and an ext. LED this base has fast connectors (blue and grey respectively).

3312F Analog Base. Like 3312FL but no connector (grey) for an ext. LED.



4313 Analog Base with isolator. An analog detector (Sensor) is to be plugged in 4313. Terminals for an ext. LED (2218). Prepared for mechanical lock of the detector - if required. Recess for label holder (3391). It has also a built-in short circuit isolator (see page 50). The isolator's COM loop address is set with the Address setting tool (3314). The base has an address label on which both the plugged-in detector's COM loop address and the isolator's COM loop address can be written.

The Address setting tool (3314) is also used for mode setting:

NORMAL mode: Used for 4313 in system EBL512 G3.

2330 mode: Not used in system EBL512 G3.

2312 mode: Not used in system EBL512 G3.

9.1.1.2

Addressable Manual Call Points



3333 Addressable Manual Call Point.²³ 3333 conforms to EN54-11. A built-in LED will indicate that fire alarm is generated, i.e. the glass is broken. Routine testing can be performed with a supplied test key, without breaking the glass. A hinged polycarbonate flap is protecting the glass. The COM loop address is set with the Address setting tool (3314).

3333 is to be surface mounted in the supplied red back box or flush mounted on a Swedish 65mm circular mounting box.

For indoor use and in dry premises.

The Address setting tool (3314) is also used for mode setting.

NORMAL mode: Flashing or not flashing LED (see Product leaflet MEW00097) is set via WinG3.

2330 mode: Not used in system EBL512 G3.

2312 mode: Not used in system EBL512 G3.

²² This base will be replaced by 3312FL and 3312F.

²³ The manual call points have a response time ≤ 5 s.



3339 Enclosed Addressable Manual Call Point.²³ 3339 is like the 3333 unit but with another type of back-box (incl. a tightening gasket). For surface mounting. For indoor use in premises where IP56 rating is required. Operating temp. -10 to +55°C.

9.1.1.3

Analog Detectors



3308 Analog heat detector. 3308 shall be plugged in an analog base (3312 / 3312F / 3312FL / 4313). Built-in LED that is lit to indicate that the detector has activated a fire alarm. Prepared for mechanical lock (screw attached) – if required. The COM loop address is set with the Address setting tool (3314). The detector has an address label on which the programmed COM loop address can be written.

The Address setting tool (3314) is also used for mode setting:
NORMAL mode: 3308 is in this mode via WinG3 set to one of three algorithms (static response temp. range) for class:

A1 (54-65°C), min./**typical**/max. ambient temp. -20/+25/+50°C

A2 S (54-70°C), min./**typical**/max. ambient temp. -20/+25/+50°C

B S (69-85°C), min./**typical**/max. ambient temp. -20/+40/+65°C

2330 mode: Not used in system EBL512 G3.

2312 mode: Not used in system EBL512 G3.



3309 Analog heat detector. Enclosed (IP67)²⁴. Built-in LED that is lit to indicate that the detector has generated fire alarm. Terminals for an ext. LED (2218). Recess for label holder (3391). The COM loop address is set with the Address setting tool (3314). The Address setting tool 3314 is also used for mode setting:

NORMAL mode: 3309 is in this mode via WinG3 set to one of three algorithms (static response temp. range) for class:

A1 (54-65°C), min./**typical**/max. ambient temp. -20/+25/+50°C

A2 S (54-70°C), min./**typical**/max. ambient temp. -20/+25/+50°C

B S (69-85°C), min./**typical**/max. ambient temp. -20/+40/+65°C

2330 mode: Not used in system EBL512 G3.

2312 mode: Not used in system EBL512 G3.



4300 Analog multi detector. 4300 is a smoke detector and a heat detector within one housing. Scattered light (i.e. reflection of infrared light) is used to detect **smoke** and the **heat** sensing element is a thermistor. The detector unit (actually the heat detector) can detect a methylated spirits (alcohol) fire (EN54-9, test fire TF6; liquid fire), which normally is impossible for a photo electric smoke detector to detect.

The detector has unleaded soldering.

Shall be plugged in an analog base (3312 / 3312F / 3312FL /

²⁴ This detector holds the ATEX classification:

Ex II 3GD EEx nA II T5 (T 70°C), -20°C ≤ T_a ≤ 65°C.

4313). Built-in LEDs are lit to indicate that the detector²⁵ has activated a fire alarm. Prepared for mechanical lock (screw attached) – if required.

Via WinG3, it is set how the detector shall operate:

Zone-Addr. 001-01 (smoke) 001-02 (heat) COM loop address e.g. 123

a) Two presentation numbers (addresses): The detector unit works as two separate detectors. The smoke detector is programmed for one zone-address and the heat detector for another zone-address²⁶. (Can be used to disable e.g. the smoke detector during working hours and/or in control expressions for programmable outputs).

Zone-Addr. 001-01 (smoke or heat) COM loop address e.g. 123

b) One presentation number (address): The detector unit works as one detector and is programmed for one zone-address.

Via WinG3 is set if the detectors in alt. **b)** shall work with "OR-functionality" or with a "Decision algorithm":

b1) OR-functionality: Either the heat detector **or** the smoke detector will activate fire alarm. This alternative is recommended in most cases.

b2) Decision algorithm:

Fire alarm will be activated if:

temperature (°C) + adjusted smoke value²⁷ ≥ 58.

Pre-warning will be activated if:

58 > temperature (°C) + adjusted smoke value²⁷ ≥ 50.

The "Decision algorithm"²⁸, see figure can be used to reduce so called false alarms (nuisance alarms), because at a normal room temperature, more smoke is required to activate fire alarm than when the room temperature is high (or is rising). By a real fire, the room temperature will rise rather fast and less and less smoke is required to activate fire alarm. Very little smoke require a "high" temperature to activate fire alarm and very much smoke will activate fire alarm also at a "low" temperature.

20°C => 3.8 %/m ↓ 40°C => 1.8 %/m

²⁵ I.e. the heat detector and/or the smoke detector.

²⁶ The zone number has to be the same for both detectors. **NOTE!** When counting alarm points these "two detectors" are regarded as two alarm points.

²⁷ Adjusted smoke value = obscuration (%/m) x 10. Default heat alarm levels (50°C / 58°C) and smoke alarm offsets (50 / 58) can be changed via WinG3. The temp. can not be lower than 0°C in the algorithm / graph.

²⁸ The decision algorithm is a violation to the EN54-7 standard.

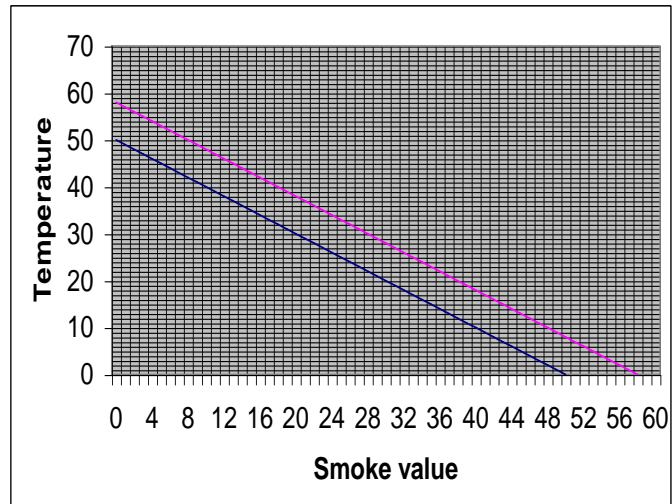

Figure 8. When the calculated value in the decision algorithm exceeds the lower graph, pre-warning will be activated. When it exceeds the upper graph, fire alarm will be activated.
Temperature = °C. Smoke value = obscuration (%/m) x 10.

The Analog multi detector's COM loop address (Technical address) is set with the Address setting tool (3314). The detector has an address label on which the programmed technical address can be written.

NOTE!

*The multi detector in system EBL512 G3 takes **two** COM loop (technical) addresses, one address that is set with the 3314 tool but also the following address that will be "occupied" for the heat part of the detector and cannot be used by any other unit on the COM loop.*

The Address setting tool 3314 is also used for mode setting:

NORMAL mode: 4300 in this mode is in WinG3, for the smoke detector, set to one of six algorithms H-15, H-35, L-15, L-35, **N-15** or N-35 and for the heat detector set to one of three algorithms for class **A1** (static response temp. 54-65°C), A2 S (54-70°C) or B S (69-85°C).

2330 mode: Not used in system EBL512 G3.

2312 mode: Not used in system EBL512 G3.



4301 Analog photo electric smoke detector. Scattered light (i.e. reflection of infrared light) is used to detect smoke.

The detector has unleaded soldering.

Shall be plugged in an analog base (3312 / 3312F / 3312FL / 4313). Built-in LEDs are lit to indicate that the detector has activated fire alarm. Prepared for mechanical lock (screw attached) – if required.

The COM loop address is set with the Address setting tool (3314). The detector has an address label on which the programmed COM loop address can be written.

The Address setting tool (3314) is also used for mode setting:
NORMAL mode: 4301 in this mode is in WinG3 set to one of the six algorithms H-15, H-35, L-15, L-35, N-15 or N-35.

2330 mode: Not used in system EBL512 G3.

2312 mode: Not used in system EBL512 G3.

9.1.1.4

Conventional Detector Bases (CDB)



2324 Base. A conventional detector shall be plugged in 2324. Built-in LED is lit to indicate that the detector plugged in the base has activated fire alarm. Terminals for an ext. LED (2218).

9.1.1.5

Conventional Detectors



4318 Combination heat detector. Rate-of-rise **and** fixed temperature, 59°C, heat detector class **A1 R**. Static response temp. range 54-65°C, ambient temp. min./**typical**/max. -10/+**25**/+50°C. Shall be plugged in a conventional detector base (2324).



4350 Multi detector. 4350 is a smoke detector and a heat detector within one housing. Scattered light (i.e. reflection of infrared light) is used to detect **smoke** and the **heat** sensing element is a thermistor. In order to secure the fire detection and to prevent false (nuisance) alarms, an AI function is used, i.e.

a: combined heat and smoke sensing

b: variable delay function

c: adaptive learning function

See also chapter "Cyber sensor functions, page 123.

The detector has unleaded soldering.

Shall be plugged in a conventional detector base (2324).



4352 Photoelectric smoke detector. Scattered light (i.e. reflection of infrared light) is used to detect smoke. An advanced alarm algorithm is used to secure the smoke detection and to prevent false (nuisance) alarms, e.g. a minimum of nine consecutive readings over the fire alarm level are required before the detector goes into alarm. (One reading per sec.)

The detector has unleaded soldering.

Shall be plugged in a conventional detector base (2324).



4375 Heat detector. Fixed temperature heat detector, 60°C, class **A2S** (static response temp. range 54-70°C), latching.

Min./**typical**/max. ambient temp. -10/+**25**/+40°C.

The detector has unleaded soldering. Shall be plugged in a conventional detector base (2324).

4376 Heat detector. Like 4375 but 80°C, class **BS** (static response temp. range 69-85°C), latching.

Min./**typical**/max. ambient temp. -10/+**40**/+60°C.

The detector has unleaded soldering. Shall be plugged in a conventional detector base (2324).



6295 Heat detector: Enclosed (IP67)²⁹. Fixed temperature heat detector, 57°C, class **A2 S** (static response temp. range 54-70°C), latching.

Min./**typical**/max. ambient temp. -40/+25/+50°C. Built-in LED is lit to indicate that the detector has activated a fire alarm. Terminals for an ext. LED (2218).

6296 Heat detector: Enclosed (IP67)³⁰. Like 6295 but 72°C, class **B S** (static response temp. range 69-85°C), latching.

Min./**typical**/max. ambient temp. -40/+40/+65°C. Built-in LED is lit to indicate that the detector has activated a fire alarm. Terminals for an ext. LED (2218).

6297 Heat detector: Enclosed (IP67). Like 6295 but 87°C, class **C S** (static response temp. range 84-100°C), latching.

Min./**typical**/max. ambient temp. -40/+55/+80°C. Built-in LED is lit to indicate that the detector has activated a fire alarm. Terminals for an ext. LED (2218).

6298 Heat detector: Enclosed (IP67). Like 6295 but 117°C, class **E S** (static response temp. range 114-130°C), latching.

Min./**typical**/max. ambient temp. -40/+85/+110°C. **No** built-in LED but terminals for an ext. LED (2218) - to indicate that the detector has activated a fire alarm.

9.1.1.6

Accessories



3314 Address setting tool. Is used to write or read the units' **COM loop address** (Technical address 001-255). It is also used to write or read the mode, see the unit respectively. In system EBL512 G3 shall **NORMAL** mode always be used. A connection cable with crocodile clips and tab terminals is supplied with the tool and can be used when required.

Put the ON/OFF switch in position ON and wait for a beep. Plug the detector's SA & SB terminals onto the tool's SA & SB terminals or, when required, use the connection cable.³¹

How to read: Press "READ", wait for a beep and read the address and mode.

How to write: To select the mode, press "WRITE" and "READ" at the same time **and/or** write the address. Press "WRITE" and wait for a beep. ("READ" again as a check.)

²⁹ This detector holds the ATEX classification:

Ex II 3GD EEx nA II T5 (T 100°C), -40°C ≤ T_a ≤ 50°C.

³⁰ This detector holds the ATEX classification:

Ex II 3GD EEx nA II T5 (T 100°C), -40°C ≤ T_a ≤ 65°C.

³¹ Some units have flying leads for easier connection. After use they should be disconnected and thrown away.



3390 Label holder. To be mounted in an analog base (3312 / 3312F / 3312FL / 4313)³². Intended for a label with "zone-address", "technical address", etc. to be read also when the detector is plugged in its base. 100 label holders per packet. Excl. labels.

3391 Labels for 3390. A packet with self-adhesive white labels for label holder 3390. 10 A4-sheets à 132 labels for laser printer usage. The print-out is done via WinG3.

9.1.2

Addressable I/O units



3361 Addressable multipurpose I/O unit.³³ Power supplied via the COM loop. The unit has two programmable inputs:

Monitored input

...used as **zone line input (Z)** (terminals 6 & 7): End-of-line capacitor 470 nF mounted in the last unit on the zone line. Short circuit on the line can generate a fault or a fire alarm (set via WinG3). This input is intended for conventional detectors.³⁴ Max. 1.5 mA. Cable: Max. 50 ohms and max. 50 nF.

...used as **general input (In0)** (terminals 5 & 7): An input for NC or NO contacts (set via WinG3).

Isolated input (In1) (terminals 8 & 9): An optocoupler input (external 24 V DC / 8 mA is required). Normally low or high (set via WinG3).

The unit has two **programmable** relay³⁵ outputs:

Relay output (Re0): NC or NO contacts (set via WinG3).

Relay output (Re1): Like Re0.

Connections and examples, see drawings 512G3 - 31 & - 36. Unit dimensions: (L x W x H) 90 x 70 x 32 mm.

A plastic protection cover is attached. The cover dimensions: (L x W x H) 129 x 73 x 45 mm.

3361 is intended to be surface mounted and for indoor use in dry premises. When required, the unit can be mounted in a Waterproof (IP66 / 67) box (3362). 3361 has an LED to indicate communication "OK" or alarm condition. For more information, see the Product Leaflet. The COM loop address is set with the Address setting tool (3314). The unit has an

³² Also in an enclosed analog heat detector (3309).

³³ The same physical unit (3361) is also used for Fan control together with the Fan control panel 4593. Then it has a separate dialog box in WinG3.

³⁴ It is via WinG3 possible to define this input to function like a manual call point ("Used as MCP"), i.e. it will **not** be collectively disabled via menu "Disable zone, H2/B1", can **not** be included in two-unit dependence, it can **not** use the "alarm delay" function and it can **not** be disabled via a time channel.

³⁵ Relay contacts: max. 2 A @ 30 V DC / 125 V AC.

address label on which the unit's COM loop address can be written.

The Address setting tool (3314) is also used for the mode setting:

NORMAL mode: Used for 3361 in system EBL512 G3.

2330 mode: Not used in system EBL512 G3.

2312 mode: Not used in system EBL512 G3.



3364 Addressable 2 voltage outputs unit. The unit is connected to a COM loop. External 24 V DC power supply is required (via a 3366 unit or EBL512 G3).

The unit has two programmable and supervised voltage outputs (VO0-VO1), intended for alarm devices (e.g. sirens). An end-of-line capacitor (470nF) is to be mounted in the last device alt. a capacitor (470nF) in up to five alarm devices:

The unit also has a special voltage output (VO2) intended for fire door closing only. The trigger condition "Fire door closing" and the controlling detectors have to be programmed. The "fire door closing function" is described on page 90 and besides that function the output VO2 will also be powerless approx. 30 sec. after:

- the "/Mains OK input" (terminal 8.) goes high, see below.
- the COM loop communication is interrupted = 3364 has no connection / communication with the c.i.e.

The unit also has two inputs, i.e. one for power supply (24 V DC) and one for "/Mains OK".

VO0: Normally low or high (set via WinG3), 24 V DC, 1 A.³⁶

VO1: Like VO0.

VO2: Normally high, 24 V DC, 1 A.³⁶ (Fire door closing function.)

24 V DC: From an external power supply (unit 3366 or EBL512 G3)

/Mains OK: From an external power supply unit (3366) when the fire door closing function (ABDL) is to be used. Normally low = The main power source (230 V AC) in the External power supply unit is okay.

Connections and examples, see drawings 512 G3 - 31 & - 38. Unit dimensions: (L x W x H) 90 x 70 x 32 mm. A plastic protection cover is attached. The cover dimensions: (L x W x H) 129 x 73 x 45 mm. The unit is intended to be surface mounted and for indoor use in dry premises. When required, the unit can be mounted in a Waterproof box (IP66 / 67) 3362.

For more information, see the Technical Description and the Product Leaflet.

The COM loop address is set with the Address setting tool (3314). The unit has an address label on which the programmed

³⁶ Cont. 1 A, during 10 ms 1.4 A.

technical address can be written.

The Address setting tool (3314) is also used for mode setting:

NORMAL mode: Used for 3364 in system EBL512 G3.

2330 mode: Not used in system EBL512 G3.

2312 mode: Not used in system EBL512 G3.

NOTE! See also chapter "Limitations", page 169.

9.1.3

Alarm devices (addressable sounders)



3377 Addressable siren. The siren is connected to a COM loop. It is power supplied via the COM loop, i.e. the number of sirens is depending on the type and number of other units connected to the COM loop.³⁷ Red ABS plastic housing. Three sound types (tones) and three priority levels are available.

Steady (cont.) 990 Hz

Intermittent (pulsed) 990 Hz, 0.5s / 0.5s (1 Hz)

Alternating (two-tone) 990 / 650 Hz, 0.25s / 0.25s (2 Hz)

For each level an output control expression and a sound type is programmed (via WinG3). For more technical data, see the Product Leaflet.

The COM loop address is set with the Address setting tool (3314).

The Address setting tool (3314) is also used for mode setting:

NORMAL mode: Used for 3377 in system EBL512 G3.

2330 mode: Not used in system EBL512 G3.

2312 mode: Not used in system EBL512 G3.

NOTE! See also chapter "Limitations", page 169.



3379 Addressable sounder base.³⁸ 3379 consists of an analog base (3312) mounted together with a sounder. 3379 is mounted in the ceiling. An analog detector can be plugged in the base, which has screw terminals for the COM loop and an ext. LED (2218). Prepared for mechanical lock of the detector - if required. Recess for label holder (3391). 3379 is power supplied via the COM loop, i.e. the number of sounder bases is depending on the type and number of other units connected to the COM loop³⁷. Three sound types (tones) and three priority levels are available.

Steady (cont.) 3650 Hz

Intermittent (pulsed) 3650 Hz, 0.5s / 0.5s (1 Hz)

Intermittent (pulsed) 3650 Hz, 0.167s / 0.167s (3 Hz)

For each level an output control expression and a sound type is programmed (via WinG3). For more technical data, see the Product Leaflet.

The COM loop address is set with the Address setting tool (3314). The unit has an address label on which the programmed COM loop address can be written. (The detector has its own COM loop address set via the Address setting tool 3314.)

³⁷ The number of 3377 + 3379 units must be ≤ 50 .

³⁸ This unit has replaced the Sounder base 3378.

The Address setting tool 3314 is also used for mode setting:

NORMAL mode: Used for 3379 in system EBL512 G3.

2330 mode: Not used in system EBL512 G3.

2312 mode: Not used in system EBL512 G3.

NOTE! See also chapter "Limitations", page 169.



4380 Addressable beacon. The LED beacon is connected to a COM loop. It is power supplied via the COM loop, i.e. the number of beacons is depending on the type and number of other units connected to the COM loop but max. 10 per COM loop. Red ABS plastic housing and PC lens. 1 Cd light output. The flash rate is 1 Hz. An output control expression is programmed (via WinG3). For more technical data, see the Product Leaflet.

The COM loop address is set with the Address setting tool (3314). The beacon has an address label on which the programmed address can be written.

The Address setting tool (3314) is also used for mode setting:

NORMAL mode: Used for 4380 in system EBL512 G3.

2330 mode: Not used in system EBL512 G3.

2312 mode: Not used in system EBL512 G3.

9.1.4

Short circuit isolators (addressable)

Each COM loop short circuit isolator is to be programmed (via WinG3) regarding:

- COM loop address
- Name (Normally not changed)
- Sequence Number (Serial Number in the COM loop's A-direction.)

Connections, see dwg 512 G3 - 31. (See especially the L / SA wire!)



4313 Analog base with isolator.³⁹ 4313 is an analog base with a built-in short circuit isolator. In case of short circuit on the COM loop, the number of disabled units will be minimised. 4313 is power supplied via the COM loop. For more information, see the Product Leaflet. The COM loop address is set with the Address setting tool (3314). The unit has an address label on which the programmed COM loop address is to be written.

The Address setting tool (3314) is also used for mode setting:

NORMAL mode: Used for 4313 in system EBL512 G3.

2330 mode: Not used in system EBL512 G3.

2312 mode: Not used in system EBL512 G3.

According to the EN54 standard, at least one short circuit isolator is required per 32 alarm points on the COM loop. In the Australian and New Zealand conventions at least one isolator per 40 alarm points.

Up to sixteen 4313 can be used, which gives seventeen loop segments. Each isolator has to be given a Sequence Number, 00-15. The isolators have to be connected consecutively (Sequence Number 00-

³⁹ This unit has replaced the Addr. isolator 4370.

01-02-03-04-05-06-07-08-09-10-11-12-13-14-15) in the COM loop's A-direction. **NOTE!** EBL512 G3 has one built-in isolator in the-A direction (no. "A") and one in the B-direction (no. "B").

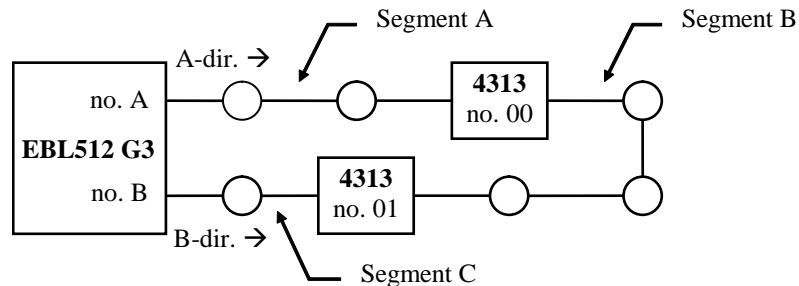

Figure 9. Two 4313 isolators connected to a COM loop gives three loop segments, i.e. Segment A (A-00), B (00-01) and C (01-B). If more isolators have to be added, the sequence numbers have to be updated (via WinG3), e.g. if one isolator is put in between isolator no. 00 and no. 01 in the figure, the new isolator has to be no. 01 and the old no. 01 has to be no. 02.

Short circuit / cut-off (break) on the COM loop

See chapter "COM loop units", page 38. See also EBL512 G3 Operating Instructions, chapter "Fault messages".

9.1.5

Units for Hazardous (Ex) areas

In hazardous (Ex) areas, Intrinsically Safe (IS) and approved products are required. The IS alarm points are connected to an interface outside the Ex area.

Normally the analog addressable units (IS smoke and heat detectors) shall be used, else conventional units (e.g. IS manual call point).

Conventional units are connected via a Galvanic isolator MTL 5061 (2820) to an expansion board 4580 Ex zone line input. See also drawings 512 G3 – 33 and – 37.

Analog / addressable units are connected to a COM loop via an IS barrier unit 2842. See also drawing 512 G3 – 31.

9.1.5.1

Galvanic isolators / IS barrier units



MTL5061 Galvanic isolator (2820). The isolator is used to connect conventional IS detectors and manual call points to an expansion board 4580 zone line input (programmed in "Resistor-Ex" mode). The isolator has two zone line inputs and two outputs (Channel 1 & 2) and it is mounted in a Waterproof box (IP66/67). Four compression glands for the cable entries and an end-of-line resistor (10K) with an area >230 mm² are supplied. Box dimensions (L x W x H): 175 x 125 x 150 mm. BASEEFA classification: EEx ia IIC T_{amb}=60°C.



2842 Intrinsically safe (IS) barrier unit.⁴⁰ The barrier unit is used to connect analog addressable IS detectors to a COM loop. The unit has connectors for COM loop in / out, external power supply (24 V DC, 60 mA) and one IS COM line for connection of up to 20 IS detectors 2840 and 2841. It is mounted in a Waterproof box (IP66/67). Five compression glands for the cable entries are supplied. Box dimensions (L x W x H): 280 x 280 x 133 mm. ATEX class: Ex ia IIC.

9.1.5.2

Intrinsically Safe mounting bases



YBN-R / 4 IS Intrinsically Safe mounting base (2812). In the base can be plugged an intrinsically safe conventional smoke (2810) or heat (2811) detector. The base has terminals for the zone line (in/out) and for an ext. LED.

9.1.5.3

Intrinsically Safe photoelectric smoke detectors



SLR-E-IS Intrinsically Safe photoelectric smoke detector (2810).

A conventional photoelectric (optical) smoke detector, shall be plugged in the intrinsically safe mounting base. The detector has two built-in LEDs that are lit to indicate that the detector has generated fire alarm. Zone classification: Cat. 1, 2 or 3. BASEEFA classification: II 1G EEx ia IIC T5 (-20°C < 55°C). Max 20 per zone.



2840 Analog IS smoke detector.⁴⁰ An analog / addressable photoelectric smoke detector. The detector is supplied with a back-box and three cable glands. The detector has one built-in LED to indicate that the detector has generated fire alarm. The function is similar to the analog photoelectric smoke detector 4301, see page 44. It has to be connected to a COM loop via an IS barrier unit 2842. ATEX class: Ex ia IIC T5.

9.1.5.4

Intrinsically Safe heat detectors



DCD-1E-IS Intrinsically Safe heat detector. A conventional Rate of Rise heat detector, fixed temperature 60°C (class A1), shall be plugged in the intrinsically safe mounting base. Two built-in LEDs that are lit to indicate that the detector has generated fire alarm. Zone classification: Cat. 1, 2 or 3. BASEEFA classification: II 1 G EEx ia IIC T5, T_{amb}=55°C. Max 20 per zone.



2841 Analog IS heat detector.⁴⁰ An analog / addressable heat detector. The detector is supplied with a back-box and three cable glands. The detector has one built-in LED to indicate that the detector has generated fire alarm. The function is similar to the analog heat detector 3308, see page 42. It has to be

⁴⁰ This unit might still be under construction.

connected to a COM loop via an IS barrier unit 2842. ATEX class: Ex ia IIC T5

9.1.6



Other COM loop units

3366 External power supply. Conforms to EN54-4. 3366 is connected to a COM loop, i.e. it is monitored from EBL512 G3 and e.g. loss of the main power source will generate a fault in EBL512 G3. It can be used as power supply for external equipment requiring 24 V DC with battery backup, e.g. the 3364 unit (see page 48). It also has a "/Mains OK" output (normally low), intended to be connected to the corresponding input on the 3364 unit.

A light grey metal housing (HxWxD, 288 x 400 x 95 mm). There is **space** for two maintenance-free sealed Lead-Acid backup batteries, 2 x 12 V, 7.5 Ah as the second power source. Batteries with higher capacity (up to 65 Ah) have to be placed outside the housing. There are cable inlets on the top, bottom and back sides of the housing. Two cable glands are supplied. The unit has one **24 V DC⁴¹ power supply output** for external equipment with up to **2.1 A** or **0.85 A** continuous current consumption, at the same time as battery charging is active.⁴² In case of an activated fire alarm in the system, the continuous current consumption can be up to **4 A**.

It has a number of security functions, e.g. against to high current output and to low battery voltage etc. For more information, see the Technical Description and the Product Leaflet. See also drawings 512 G3 – 31 and – 38.

The COM loop address is set with the Address setting tool (3314). The unit has an address label on which the programmed technical address can be written.

The Address setting tool (3314) is also used for the mode setting:

NORMAL mode: Used for 3366 in system EBL512 G3.

2330 mode: Not used in system EBL512 G3.

2312 mode: Not used in system EBL512 G3.

⁴¹ The rated output voltage for the main power source (rectifier) is 24 V ± 1%. Max. ripple 500 mVp-p. The rated output voltage for the second power source (the backup battery) is 18 – 28 V DC. **NOTE!** The voltage will, however, decrease to approx. 15 V when the output will be switched off in order not to damage the battery.

⁴² A current consumption of **0.85-2.1 A** allows only the "**low current charging mode**", i.e. the battery capacity can be **up to 27 Ah**.

A current consumption ≤ **0.85 A** allows the "**high current charging mode**", i.e. the battery capacity can be **up to 65 Ah**.

AAFC Alarm Acknowledgement Facility Control.⁴³ The **AAFC** is a box with an alarm indication LED and a non-latching switch "Press to acknowledge false alarm". One **AAFC** per **AAFC** zone and up to 100 **AAFC**:s zones can be used. The COM loop address is set with the Address setting tool (3314). See also chapter "**Alarm Acknowledgement Facility (AAF)**", page 106.



4593 Fan control panel. A panel for control of eight fans. It contains of a light grey mounting plate, two **Fan control application boards 4594** and two fronts with LEDs and push buttons for the Fan control functions. The panel is intended to be mounted in the General control cabinet **4590**, in which three Fan control panels **4593** can be mounted. For connection to the c.i.e. is one I/O Matrix board **4582** required for each 4594 board. Each 4594 board is connected to a COM loop and 24 V DC. Up to eight **4593** panels can be used (i.e. sixteen 4594 with 4582). One I/O unit **3361** is also required for each fan. For more information, see Technical Description MEW01245.



4601 Wireless photoelectric smoke detector.⁴⁰ The detector is plugged in an attached base and the colour is white. Latest IC technology will secure the highest reliability possible. The smoke detection chamber contains an IR LED and a photodiode. Scattered light (i.e. reflection of infrared light) is used to detect smoke. The smoke enters the detection chamber through an insect filter and an optical labyrinth. Fire alarm will be activated after three values over the fire alarm threshold level. The detector has sensitivity compensation for contamination. Transmission distance between Detector and Base station is min. 40 m in open air. The Wireless smoke detector is power supplied by three pieces of a 3 V Lithium 2400 mAh battery, type 4602. The battery life time is more than three years.

Up to 16 Wireless photoelectric smoke detectors (4601) can be "connected" to an **Addressable Base station for wireless units (4610)**. Each wireless detector shall be programmed like the Analog photoelectric smoke detector (4301) regarding presentation number (Zone-Address), alarm text, etc. For more information, see the Technical Description and the Product Leaflet.



4610 Addressable Base station for wireless units.⁴⁰ The Base station consists of a p.c.b. mounted in a white plastic housing, which has a great number of cable inlets and mounting holes. It has fast connectors for the COM loop (in / out) and 24 V DC power supply respectively. Up to four Base stations can be connected to a COM loop in the EBL system and up to 16 (detector address 0-15) Wireless photoelectric smoke detectors (4601)

⁴³ This unit is available on the Australian market only.

can be "connected" to each Addressable Base station for wireless units (4610). Each Base station shall have a transmission channel (0-3) selected. The Base station's COM loop address is set on a DIL-switch. The COM loop address for the wireless detector respectively is depending on the Base station's COM loop address, see below. Ext. 24 V DC power supply is required. For more information, see the Technical Description and the Product Leaflet. See also drawing 512 G3 – 31.

9.1.7 COM loop addresses for Base station and Wireless detectors

Each Base station takes one COM loop address (012 in the example below).

Each wireless detector's COM loop address will be as follows:

Detector address	COM loop address
0	Base station's COM loop address +1 (e.g. 012+1=013)
1	Base station's COM loop address +2 (e.g. 012+2=014)
..and so on..	
15	Base station's COM loop address +16 (e.g. 012+16=028)

NOTE! Since the highest possible COM loop address is 255 the highest possible COM loop address for a Base station is 239 if 16 Wireless smoke detectors shall be supported (239+16=255).

9.2 Units connected to the RS485 interface

Up to sixteen Display Units type Ext. FBPs (1826 / 1828) and/or Alert Annunciation Units (1735 / 1736) and/or Ext. Presentation Units (1728) can be connected to the built-in RS485 interface (J4:37-38) in EBL512 G3. Note that the current consumption for 1826 with printer can be up to 200 mA when printing. (Power supply at J4:35-36.) Connections, see drawing 512 G3 – 24.

NOTE! Display Unit software version $\geq 1.4.1$ is required.

Address and S/W mode settings

The display and the push buttons (in the unit respectively) are used to set the address, which also can be changed via EBL512 G3. The S/W mode shall be set to **xxxx – 1587** (xxxx = type number). See the Technical Description for the unit respectively.

The first unit shall have the address 00, the second unit address 01 and so on⁴⁴. Follow the Address setting instructions in the Technical Description for the unit respectively.

⁴⁴ The connection order on the line is not dependent of the address.

Via WinG3 can "Selective alarm presentation" be programmed, i.e. you can select which alarms that shall be presented in each unit, see the Technical Description for the unit respectively.

NOTE! As an **alternative**, German Fire Brigade Panels (see page 59) can be connected to the RS485 interface.

9.2.1



External Fire Brigade Panels

1826 External Fire Brigade Panel (ext. FBP). A light grey metal housing (HxWxD, 290x 415 x 128 mm) with a door. A key is required to open the door, which has a Plexiglas ahead of the FBP front. It has cable inlets on the top, bottom and back sides and is intended to be wall mounted. Two compression glands are attached.

LED indicators and push buttons on the front are like the upper black part of the EBL128 / 512 front. **The front's designation texts are in Swedish.** A neutral front is available, where the **designation texts, in any language**, are made separately and by production put into a transparent "text slot" for the LED and push button respectively.

All or selected alarms will be presented in a display (alphanumeric LCD, 2x40 characters), with back-light. An alarm text will also be presented together with each alarm, if programmed in EBL512 G3. Furthermore, at least 617 texts for selected fire alarms can be stored in the unit and will in such a case be shown, instead of the texts sent from EBL512 G3 for these alarms. These text messages will be downloaded to the unit via EBL512 G3. A built-in buzzer will sound like in EBL512 G3. The buzzer can be silenced and the alarm devices in the installation can be silenced. They will re-sound for a new alarm.⁴⁵ When there are queued alarms in the system, you can scroll amongst them and they can be reset. Any fault in the system will be presented as "General fault in system" and the buzzer will sound.⁴⁶ A **Printer 1835** can be mounted in ext. FBP 1826. It will print all the alarms, including the alarm texts. New S/W versions can be downloaded directly in the unit. The unit is power supplied from EBL512 G3 or an ext. power supply.

The unit shall run in **S/W mode 1826/28 – 1587**. Up to 1200 m cable can be used. For more information, see Technical description MEW00249.



1828 External Fire Brigade Panel (ext. FBP). "Like" 1826 but with a compact size enclosure (HxWxD, 145 x 220 x 50 mm) made of grey high impact ABS. Fitted with a supplementary "O" ring gasket, it will comply with IP61, in respect of dust and

⁴⁵ Silenced or disabled can be set via WinG3 (System properties).

⁴⁶ Not valid for the Swedish convention (SBF).

moisture. The unit has no door, i.e. the front is accessed directly but a key is required to get access to the push buttons. They are disabled until they are supposed to be used. The unit shall be wall mounted. Two compression glands are attached. In all other respects it is like 1826, except that a printer cannot be mounted in 1828.

The unit shall run in **S/W mode 1826/28 – 1587**. Up to 1200 m cable can be used. For more information, see Technical description MEW00249.

1835 Printer. Can be mounted in the External Fire Brigade Panel **1826**. It will print all the alarms, including the alarm texts. Note that the printer current consumption is up to 200 mA when printing.

9.2.2

Alert Annunciation Units

When the Alert Annunciation (**AA**) function shall be used in system EBL512 G3, a unit is required for the related manoeuvres, i.e. to acknowledge / reset the **AA** alarms. For a detailed description of the Alert Annunciation function, see chapter "Alert Annunciation", page 104.



1735 Alert Annunciation Unit (AAU). A compact size enclosure (HxWxD, 145 x 220 x 50 mm) made of grey high impact ABS. Fitted with a supplementary "O" ring gasket, it will comply with IP61, in respect of dust and moisture. The unit has no door, i.e. the front is accessed directly but the push buttons are disabled until they are supposed to be used. The unit shall be wall mounted. Two compression glands are attached. **The front's designation texts are in Swedish.**

All or selected fire alarms will be presented in a display (alphanumeric LCD, 2x40 characters), with back-light. An alarm text will also be presented together with each alarm, if programmed in EBL512 G3. Furthermore, at least 617 texts can for selected fire alarms be stored in the unit and will in such a case be shown, instead of the texts sent out from EBL512 G3 for these alarms. These text messages will be downloaded to the unit via EBL512 G3. A built-in buzzer will sound to indicate a not acknowledged **AA** alarm.

New software versions can be downloaded directly in the unit. The unit is power supplied from EBL512 G3 or an external power supply.

The unit has the following LEDs:

Fire and Alarms queued, indicating fire / **AA** alarm.

Operation, indicating that the unit is in operation, i.e. the **AA** function is enabled in the system. A time channel can be used to enable the **AA** function.

Fire brigade alerted, indicating that the "Fire brigade tx" output is activated in EBL512 G3 because:

- the activated fire alarm is not an **AA** alarm
- the **AA** function has been ended, e.g. the acknowledge or investigation time respectively has run out, etc.

Acknowledge, indicating that the **AA** alarm has been acknowledged.

The unit has the following push buttons:

Alarms queued, used to scroll amongst the alarms.

Acknowledge, used to acknowledge an **AA** alarm and hereby also silence the buzzer.

Reset, used to reset an **AA** alarm.

The unit shall run in **S/W mode 1735 – 1587**. Up to 1200 m cable can be used. For more information, see Technical description MEW00224.

1736 Alert Annunciation Unit (AAU). This unit is like 1735, except it has a neutral front, where the **designation texts, in any language**, are made separately and by production put into a transparent "text slot" for the LED and push button respectively. (This front also holds one extra LED & two extra push buttons.).

The unit shall run in **S/W mode 1736 – 1587**. Up to 1200 m cable can be used. For more information, see Technical description MEW00224.

9.2.3



External Presentation Units

1728 External Presentation unit (EPU). A compact size enclosure (HxWxD, 145 x 220 x 50 mm) made of grey high impact ABS. Fitted with a supplementary "O" ring gasket, it will comply with IP61, in respect of dust and moisture. The unit has no door, i.e. the front is accessed directly, when required. The push buttons are disabled until they are supposed to be used. The unit shall be wall mounted. Two compression glands are attached. **The front's designation texts are in Swedish.** This unit is intended for pre-warning, co-incident⁴⁷, fire (and heavy smoke / heat) alarm presentation. If there are two or more alarms in the system, you can scroll amongst them but the fire alarms cannot be reset via this unit.

All or selected alarms will be presented in a display (alpha-numeric LCD, 2x40 characters), with back-light. An alarm text will also be presented together with each alarm, if programmed in EBL512 G3. Furthermore, at least 617 texts can for selected fire alarms be stored in the unit and will in such a case be shown, instead of the texts sent out from EBL512 G3 for these alarms. These text messages will be downloaded to the unit via

⁴⁷ Two zone / address dependence.

EBL512 G3.

Any fault in the system will be presented as "General fault in system". The buzzer will sound.⁴⁶ It can be silenced. Any disablement in the system will be presented as "General disablement in system".⁴⁶

A built-in buzzer will sound like in EBL512 G3. The buzzer can be silenced but the alarm devices in the installation cannot be silenced via this unit. New software versions can be downloaded directly in the unit. The unit is power supplied from EBL512 G3 or an external power supply. The unit shall run in **S/W mode 1728 – 1587**.

The number of units that can be power supplied via EBL512 G3 (or an external power supply) is depending on all other units connected to the same c.i.e. / external power supply. Up to 1200 m cable can be used. For more information, see Technical description MEW00290.

9.2.4

German Fire Brigade Panels



FBP 2003⁴⁸ German Fire Brigade Control Panel (Feuerwehr-Bedienfeld). A grey metal housing (HxWxD, 185 x 255 x 58 mm) with a door. A key is required to open the door, which has a Plexiglas ahead of the front. It has cable inlets on the top, bottom and back sides and is intended to be wall mounted.

The function, LED indicators and push buttons on the front are in accordance with DIN 14661. **The front's designation texts are in German.** Serial RS485 interface for IHD protocol.

The unit is power supplied from EBL512 G3 (or an ext. power supply). Up to 1200 m cable can be used.



FAT 2002⁴⁹ German Fire Brigade Indicator Panel (Feuerwehr-Anzeigetableau). A grey metal housing (HxWxD, 185 x 255 x 58 mm) with a door. A key is required to open the door, which has a Plexiglas ahead of the front. It has cable inlets on the top, bottom and back sides and is intended to be wall mounted.

The function, Display information, LED indicators and push buttons on the front are in accordance with DIN 14662. **The front's designation texts are in German.** Serial RS485 interface for IHD protocol.

The unit is power supplied from EBL512 G3 (or an ext. power supply). Up to 1200 m cable can be used.

⁴⁸ IFAM GmbH Erfurth, type FBF 2003.

⁴⁹ IFAM GmbH Erfurth, type FAT 2002.

9.3 Units connected to the RS232 interface J7

9.3.1 Web-servers

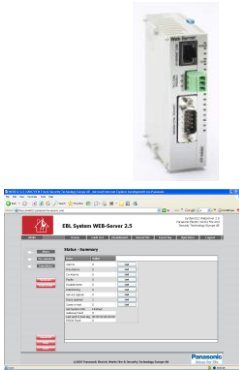

1598 Web-server II. This unit can be used:

a) for presentation of the actual c.i.e. status in a PC using the web browser Microsoft Internet Explorer. It can also send e-mails in case of pre-warning, fire alarm, fault, disablement, test mode alarm and/or service signal.

b) for remote control with encrypted and safe two-way communication and five different user (access) levels.

c) as a gateway to other PC systems etc. Three alternatives are available today:

c1) EBL Talk is an open protocol, used to transmit and present fire alarm information in a separate PC / system.

c2) Tateco, used to transmit and present fire alarm information in an Ascom Tateco paging system.

c3) SIA, used to transmit and present fire alarm information in a separate PC application.

A PC tool, **WebG3 II Config tool** is used for the configuration, which is downloaded to the web-server via TCP/IP.

The Web-server II consists of a light grey plastic cabinet (90x25x69.5 mm), which shall be vertically mounted on the symmetric 35 mm DIN rail in the EBL512 G3 c.i.e.

Web-server II has the following interfaces:

RS232 (PLC COM) to connect the web-server to J7 in the EBL512 G3 c.i.e.

RS232 (MODEM COM) to connect the web-server to other PC / system

RJ45 (10 BASE-T) to connect the web-server to Internet / an intranet (LAN)

Molex 3.5 to connect the web-server to J3 (24 V DC) in the EBL512 G3 c.i.e.

9.4 Other units

9.4.1 Alert Annunciation Controllers



1740 Alert Annunciation Controller (AAC). This unit has no display, i.e. it has to be mounted close to EBL512 G3 (or an ext. FBP) where the fire alarms will be presented.

The compact size enclosure (HxWxD, 145 x 220 x 50 mm) is made of grey high impact ABS. Fitted with a supplementary "O" ring gasket, it will comply with IP61, in respect of dust and moisture. The unit has no door, i.e. the front is accessed directly but the push buttons are disabled until they are supposed to be used. **The front's designation texts are in Swedish.**

The unit shall be wall mounted. The LED "Acknowledge" can be turned on by the push button "Acknowledge" or by an input, i.e. a programmable output. This is set via a jumper "JP1" in the unit. The unit is power supplied from EBL512 G3 or an external power supply. One supplementary compression gland can be used for cable entry.

The unit has the following LEDs:

Fire, indicating fire / **AA** alarm.

Operation, indicating that the unit is in operation, i.e. the **AA** function is enabled in the system. A time channel can be used to enable this function.

Fire brigade alerted, indicating that the "Fire brigade tx" output is activated in EBL512 G3 because:

- the activated fire alarm is not an **AA** alarm
- the **AA** function has been ended, e.g. the acknowledge or investigation time has run out, etc.

Acknowledge, indicating that the **AA** alarm has been acknowledged.

The unit has the following push buttons:

Acknowledge, used to acknowledge an **AA** alarm.

Reset, used to reset an **AA** alarm.

Connections and more details are to be found in the Technical Description MEW00283.

9.4.2

External LED

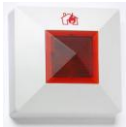

2218 Ext. LED (ext. indicator). Used when a detector is placed out of view or hidden. The LED is lit at the same time as the LED in the detector / base it is connected to. It has a "Burning house" symbol instead of any text. 2218 can be connected to all types of Panasonic detectors / bases. The input is polarised.
J2:1 (+5 to +35 V DC) for **conventional** detectors / bases
J2:2 (+; ≤ 25 mA) for **analog** detectors / bases
J2:3 (0 V)

To be wall mounted (87 x 87 x 30 mm).

9.4.3

Alarm devices (sounders, etc.)

Regarding addressable alarm devices, see page 49.

In the Panasonic product range are no alarm devices intended for a supervised (monitored) voltage output (e.g. S0 – S3 in EBL512 G3). Connections of alarm devices according to drawings 512 G3 – 23 and -38.

9.4.4

Door release magnets

In the Panasonic product range are no Door release magnets. Door release magnets shall always be provided with a "suppression diode"

(e.g. 1N4004) in parallel with the coil, like in the alarm devices, see drawing 512 G3 - 23.

9.4.5

Boxes

3362 Waterproof box (IP66 / 67). A grey polycarbonate box with ingress protection rating IP66 / 67. Four compression glands are included for the cable entries. Dimensions (L x W x H): 175 x 125 x 75 mm. 3362 can be used for e.g.:

Addressable multipurpose I/O unit 3361

Addressable 2 voltage outputs unit 3364

9.4.6

Duct detector chambers



6377 Duct detector chamber UG-4. The housing is made of grey ABS and the venturi pipe is made of aluminium. It is supplied with four IP65 glands for cable entry. 6377 can be used in conventional as well as analog fire alarm systems, depending on the base and detector mounted inside the housing (base 2324 + 4352 or base 3312 F/FL + 4301). The venturi pipe is available with or without a built-in fan and in three lengths (0.6, 1.5 & 2.8 m). The pipe can easily be shortened to suit the ventilation duct. Mounting bracket and filters are also available. For more information see Data sheet MEW01280.

10 Programmable inputs

In each control unit are four programmable, not supervised inputs (I0-I3) available.

In EBL512 G3 can also be mounted the Inputs and Outputs expansion board 4583, with five programmable inputs (Input 0-4). See chapter "Expansion boards 458x", page 27. These inputs can be supervised or not supervised.

On the COM loops can be connected the addressable multipurpose I/O unit 3361 with two programmable inputs.

Each input is programmed (via WinG3), see dialog boxes below.

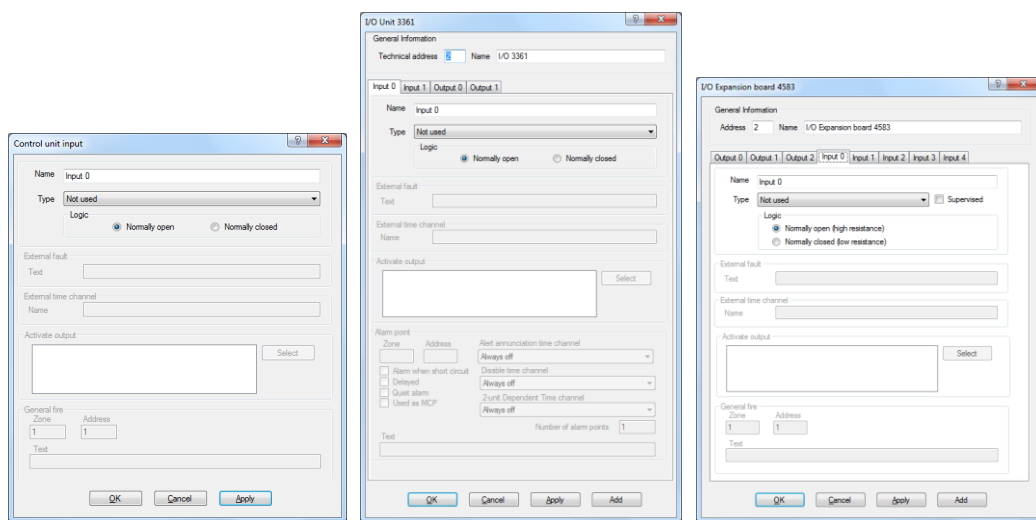

Figure 10. WinG3 "Input" dialog boxes. Different trigger conditions require different additional information, i.e. only the enabled fields can/shall be filled in. **NOTE!** The 3361 unit, Input 0, has a special input dialog box.

10.1 Control unit Inputs I0 - I3 & Inputs 0 -4 on exp. board 4583

10.1.1 Not supervised

NOTE! Only valid for the Control unit Inputs I0 – I3.

Normally open ($R > 20K$) or Normally closed ($R < 500\Omega$)

Activation time: >0.5 sec.

Connections, see drawings 512 G3 – 23 and – 35, sheet 1.

10.1.2 Supervised

NOTE! Only valid for the exp. board 4583 Inputs 0 - 4.

Each supervised input can be in four different states:

- Open circuit (cut-off)
- Not activated (quiescent)

- Activated
- Short-circuit

Depending on the selected logic, Normally open (high resistance) **or** Normally closed (low resistance), the following table is valid.

Line resistance R	Normally open (high resistance)	Normally closed (low resistance)
$R > 6K8$	Open circuit (cut-off)	Open circuit (cut-off)
$6K8 \geq R > 2K$ (nom. 3K3)	Not activated	Activated
$2K \geq R > 70$ (nom. 680)	Activated	Not activated
$R \leq 70$	Short-circuit	Short-circuit

Connections, see drawings 512 G3 – 35, sheets 1 & 2.

10.1.2.1 **Input line fault**

If open circuit (cut-off) or short-circuit is detected on a supervised input, a fault will be generated in EBL512 G3 and the following fault message will be displayed:

**FAULT: Input x expansion board x,
control unit xx**

10.2 **The 3361 unit's Inputs In0 / Z & In1**

Connections, see drawings 512 G3 – 31 and – 36.

10.2.1 **Input In0**

Input 0 can be used as a general input (In0) – like the c.i.e. inputs I0-I3 **or** used as a zone line input (Z) requiring an end-of-line capacitor (470 nF).

10.2.2 **Input In1**

Input 1 is an isolated optocoupler input requiring a NO / NC contact and external 24 V DC (8 mA).

11 Input programming

Input programming is done in WinG3. For more information see WinG3 help. Each input has to have an individual Trigger condition ("Triggered by") and Logic. It is not allowed to let two or more inputs have the same trigger condition.

11.1 Trigger conditions

The following trigger conditions are available (numbering only for the comments below):

0. **Activate output** (specified COM loop unit output)
1. **Activated fault routing equipment** (one input per C.U.)
2. **Activated Fire Ventilation** (one input per C.U.)
3. **Activated key cabinet**
4. **Activated Routing Equipment** (one input per C.U.)
5. **Alarm Key Cabinet** (one input per control unit)
6. **Alert Annunciation Acknowledge**
7. **Alert Annunciation Reset**
8. **Door Closing Test Input**
9. **Evacuate** (one input per C.U.)
10. **External Fault** (50 inputs per system)
11. **External Time Channel** (one input per time channel. 39 ext. time channels are available per system)
12. **Extinguishing alarm**
13. **Extinguishing start**⁵⁰
14. **Extinguishing stop**⁵⁰
15. **Extinguishing system fault** (one input per C.U.)
16. **Extinguishing system released** (one input per C.U.)
17. **Fault Signal External Fuses** (one input per control unit)
18. **Fault Signal External Power Supply** (one input per control unit)
19. **Fault warning routing equipment fault** (one input per C.U.)
20. **General Fire** (max. 127 per C.U.)
21. **Interlocking** (200 inputs per C.U. / 1000 per system)
22. **Loss of battery charger to external power supply** (one input per C.U.)
23. **Loss of main power source to external power supply** (one input per C.U.)
24. **Not used**
25. **NZ Silence switch**⁵¹ (one input per system)

⁵⁰ All inputs and outputs involved have to be connected to the same c.i.e.

⁵¹ Only valid for the New Zealand convention.

26. **Pre-warning** (input and corresponding fire alarm input have to be "connected" to the same C.U.)
27. **Zone Line Input**⁵²

Comments to the trigger conditions (above):

0. Activates any COM loop unit output as long as the input is active. This is valid even if the output is disabled.
1. "Activated Fault routing equipment" signal (feed-back) to EBL512 G3 will light up the LED "Fault tx activated" on the front. Output with trigger condition "Indication Fault tx Activated" will be activated.⁵³
2. Activated Ventilation equipment feedback to the EBL512 control unit to light up the LED "Ventilation".⁵⁴
3. Output with trigger condition "Activated Key cabinet" will be activated.
4. Activated Fire brigade tx feedback to the EBL512 G3 control unit to light up the LED "Fire brigade tx".⁵⁴
5. Key cabinet, where the fire brigade store there key to the building. Will activate a Key cabinet alarm. See EBL512 G3 Operating Instructions for more information.
6. Alert annunciation, see chapter "Alert Annunciation", page 104 and EBL512 G3 Operating Instructions for more information.
7. Like 6.
8. When one or more "Fire door closing" outputs are used, these outputs will be activated for 20 seconds by this trigger condition. **NOTE!** Only valid for inputs and outputs connected to the same c.i.e.
9. Normally used for the New Zealand key switch "Evacuation". The function is like the soft key "Evacuate" (P7)⁵⁵ on the c.i.e. front. The input has to be activated as long as the Evacuate function shall be on.
10. Ext. fault will activate a fault in EBL512 G3. A user definable fault message ("Error text") up to 40 characters will be shown.
11. External clock, timer, key switch, etc. can disable / re-enable alarm points. The function Alert Annunciation, etc. can be turned

⁵² Only valid for the Addressable multipurpose I/O unit 3361 input "In0", used as zone line input (Z).

⁵³ One input activated in any control unit, will light up the LED respectively in all control units.

⁵⁴ One input activated in any control unit, will light up the LED respectively in all control units.

⁵⁵ Available in some conventions only.

on / off by a time channel. Control outputs can be turned on / off by a time channel.

12. Activated input will activate a fire alarm (Zone), e.g. a sprinkler zone alarm. This trigger condition is normally used for the "New Zealand indicating panel" in order to control the function of the key switch "Silence alarms". (In case of a sprinkler alarm, the alarm devices will not be turned off by the key switch "Silence alarms".)
13. Used to start a new "countdown", see 14 below.
Push button: NO, momentary action. One or more push buttons can be used.
14. Output for Extinguishing equipment (type of output = 2) has **to have** a delayed activation **programmed** (a "countdown"). This "countdown" will be stopped when an input with trigger condition 13 is activated. To start a new "countdown", see 13 above.
Push button info: NO, latching action. One or more push buttons can be used. Manual reset of push button(s).
15. Activated input will generate a fault in EBL512 G3. Output with trigger condition "Extinguishing system fault" will be activated. The following fault message will be shown:
**FAULT: Extinguishing system,
control unit xx**
16. Activated Extinguishing equipment feedback to the EBL512 G3 control unit to light up the LED "Extinguishing".⁵⁴
17. Ext. fuses (for ext. power supply equipment) fault output will activate a fault in the EBL512 G3 system. The following fault message will be shown:
FAULT: External fuses, control unit xx
18. Ext. power supply equipment fault output will activate a fault in the EBL512 G3 system. The following fault message will be shown:
**FAULT: External power supply,
control unit xx**
19. Activated input (i.e. fault on the fault routing equipment) will generate a fault in EBL512 G3:
**FAULT: Fault warning routing equipment,
control unit xx**
20. A special detector, push button, etc. can activate a fire alarm in EBL512 G3. Zone no. and Address (+ user definable alarm text).
21. A feed-back from the equipment activated by the corresponding interlocking output. Activated input is shown in menu H9/C1. See also chapter "Interlocking function", page 86.
22. "Loss of the battery charger to external power supply equipment" fault output will activate a fault in the EBL512 G3 system. It will have the same time delay, as set for the Loss of main power

source fault for the c.i.e. The following fault message will be shown:

**FAULT: Charging external power supply,
control unit xx**

23. "Loss of main power source to external power supply equipment" fault output will activate a fault in the EBL512 G3 system. It will have the same time delay, as set for the Loss of main power source fault for the c.i.e. The following fault message will be shown:

**FAULT: Mains, external power supply,
control unit xx**

24. Default. Indicating that an input trigger condition is not selected, i.e. the input will not "activate" anything.
25. Used for the "outside switch" (i.e. the New Zealand FB silence switch). Turned on: Alarm devices and the c.i.e. buzzer will be disabled. The following fault message will be shown:

**FAULT: FB Silence switch,
control unit xx**

From Turned on to Turned off: All fire alarms will be isolated, all zones in alarm will be disabled, alarm devices and the c.i.e. buzzer will be re-enabled and the fault will be serviced.

26. Pre-warning, e.g. from a High Sensitive Smoke Detector's pre-warning output. Zone no. and Address have to be set to the same as the corresponding fire alarm (from the same detector).
27. The Addressable multipurpose I/O unit 3361 monitored Input 0 used as zone line input (Z), i.e. with end-of-line capacitor.

11.2 Logic

The logic has to be set.⁵⁶

(•) **Normally open / normally low** Normally open contact or normally low optocoupler input.

() **Normally closed / normally high** Normally closed contact or normally high optocoupler input.

11.2.1 Supervised

Valid for the Inputs and Outputs expansion board (4583) programmable inputs (Input 0-4) only.

(•) **Normally open (high resistance)**

() **Normally closed (low resistance)**

Depending on the selected logic, Normally open (high resistance, 3K3) **or** Normally closed (low resistance, 680R), the function will be according to the table on page 64.

⁵⁶ In the WinG3 dialog box "Input".

12 Programmable outputs

In each control unit are four programmable voltage outputs (S0-S3) and two programmable relay outputs (R0-R1) available. 8 relays expansion boards (4581) and Input and Output expansion board (4583) with three programmable outputs (Output 0-2) can be mounted in each EBL512 G3. See chapter "Expansion boards 458x", page 27. On the COM loops can be connected Addressable Multipurpose I/O units (3361) with two programmable relay outputs (Re0-Re1) per unit and Addressable 2 voltage outputs units (3364). Addressable siren (3377) and Addressable sounder base (3379) can also be connected on the COM loops, i.e. the units have no physical outputs, only the siren and sounder respectively.

Each output is programmed via WinG3, see dialog boxes below.

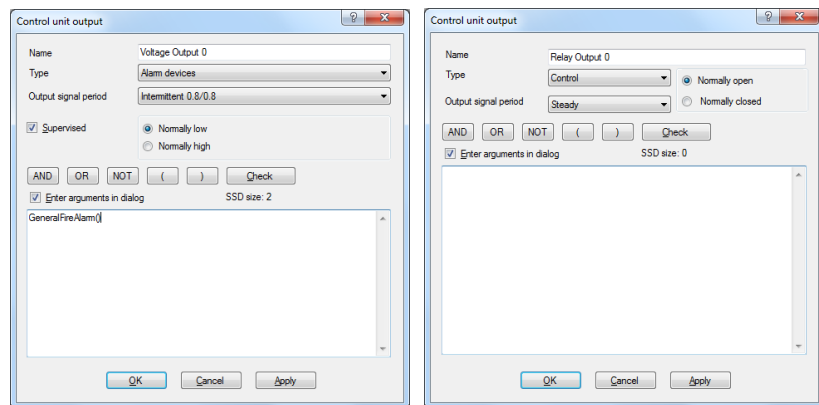

Figure 11. WinG3 Control unit Voltage Output and Relay Output dialog boxes.

Each 3377 and 3379 unit is programmed via WinG3, see dialog box below.

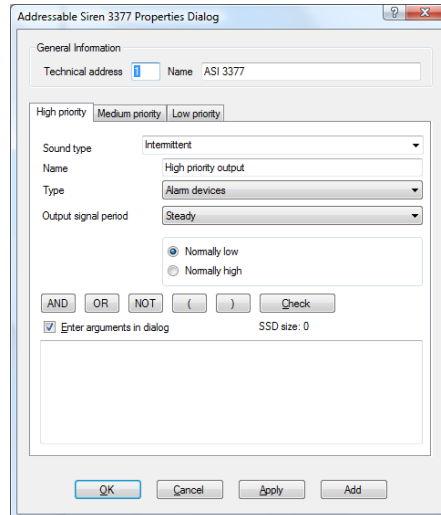

Figure 12. WinG3 "Addressable siren 3377" dialog box. The dialog box for "Addressable sounder base 3379" is similar.

12.1 Control unit outputs S0 – S3

Each control unit has four programmable, supervised (monitored)⁵⁷ voltage outputs:

S0 Supervised (monitored) voltage output, 24V DC, max. 500 mA (Fuse F4)

S1 Supervised (monitored) voltage output, 24V DC, max. 500 mA (Fuse F5)

S2 Supervised (monitored) voltage output, 24V DC, max. 500 mA (Fuse F6)

S3⁵⁸ Supervised (monitored) voltage output, 24V DC, max. 500 mA (Fuse F7)

Connections and more information, see dwg. 512 G3 - 23.

12.2 Control unit outputs R0 & R1

Each control unit has two programmable relay outputs. Relay contact ratings: 30 V, 1A.

R0 Relay output, NO or NC contacts programmable

R1 Relay output, NO or NC contacts programmable

Connections and more information, see dwg. 512 G3 - 23.

⁵⁷ This is default, but via WinG3 it is possible to set each output individually as not supervised (not monitored). A normally high output is not supervised. See also chapter "Calibration of supervised outputs", page 112.

⁵⁸ Note! This output will be low in case of system fault (via the watch dog reset circuit). May be used as a supervised voltage output for fault warning routing equipment (Fault tx).

12.3 8 relays expansion board 4581 Output 0 – Output 7

Each 4581 board has eight programmable relay outputs:

Output 0 Relay output, NO or NC contacts programmable

Output 1 Relay output, NO or NC contacts programmable

Output 2 Relay output, NO or NC contacts programmable

Output 3 Relay output, NO or NC contacts programmable

Output 4 Relay output, NO or NC contacts programmable

Output 5 Relay output, NO or NC contacts programmable

Output 6 Relay output, NO or NC contacts programmable

Output 7 Relay output, NO or NC contacts programmable

Relay contact ratings: Max. 2A @ 30 V DC.

Connections and more information, see dwg. 512 G3 – 34.

12.4 Inputs and Outputs expansion board 4583 Output 0 & Output 1

Expansion board 4583 has two programmable, supervised (monitored)⁵⁹ voltage outputs:

Output 0 Supervised (monitored) voltage output, 24V DC⁶⁰, max. 200 mA (Fuse F1).

Output 1 Supervised (monitored) voltage output, 24V DC⁶⁰, max. 200 mA (Fuse F2).

Connections and more information, see drawing 512 G3 – 35, sheet 1.

See also chapter "Inputs and outputs expansion board 4583", page 30.

12.5 The 3361 unit's Outputs Re0 & Re1

Each 3361 unit has two programmable relay outputs. Relay contact ratings: 30 V DC (125 V AC), 2A.

Re0 Relay output, NO or NC contacts programmable

Re1 Relay output, NO or NC contacts programmable

Connections and more information, see dwg. 512 G3 – 36.

12.6 The 3364 unit's VO0 – VO2

Each 3364 unit has two programmable, supervised (monitored)⁵⁷ voltage outputs:

Output **VO0** Supervised (monitored) voltage output, 24V DC⁶¹

⁵⁹ This is default, but via WinG3 it is possible to set each output individually as not supervised (not monitored). A normally high output is not supervised. See also chapter "Calibration of supervised outputs", page 112.

⁶⁰ See chapter "Technical data", page 168, regarding **system voltage**.

⁶¹ Cont. 1 A, during 10 ms 1.4 A.

Output **VO1** Supervised (monitored) voltage output, 24V DC⁶¹

Each 3364 unit also has one programmable special output, intended for fire door closing (release magnets) only:

Output **VO2** Voltage output, 24 V DC, max. 1A⁶¹. Normally high. For more information see the Technical Description MEW00529.

24 V DC is required from an external power supply unit (e.g. 3366).

Connections and more information, see dwg. 512 G3 – 31 & - 38.

12.7 The 3377 unit's Output (siren)

Each 3377 unit has one programmable output:

Output **Siren** Three priority levels and three types of tones.

Connections and more information, see dwg. 512 G3 – 31.

12.8 The 3379 unit's Output (sounder)

Each 3379 unit has one programmable output:

Output **Sounder** Three priority levels and three types of tones.

Connections and more information, see dwg. 512 G3 – 31.

12.9 The 4380 unit's Output (beacon)

Each 4380 unit has one programmable output:

Output **Beacon** (Light output 1 Cd. Flash rate 1 Hz.)

Connections and more information, see dwg. 512 G3 – 31.

13 Output programming

Output programming is done in WinG3. See the WinG3 dialog box respectively. See also WinG3 help.

13.1 Type of output

Some output types can be collective disabled. Some output types can when activated, be indicated by an LED. The following types are available (numbering only for the comments below):

0. **Control**
1. **Fire Ventilation**
2. **Extinguishing**
3. **Alarm Device**
4. **Routing equipment (Fire brigade tx)**
5. **Control, neutral**
6. **Interlocking**

Comments to the output types:

0. Default. General (normal) control output⁶²
1. Used to activate fire ventilation equipment^{62, 63}
2. Used to activate extinguishing equipment^{62, 64}
3. Used for sounders, etc.⁶⁵
4. Used for **fire brigade tx** outputs only⁶⁶
5. General (normal) control output. No collective disablement and no LED indication.
6. This output⁶² can be used together with a corresponding interlocking input. See chapter "Interlocking function", page 86. Activated output is shown in menu H9/C1.

⁶² Controlled by menu H2/B7 Disable / Re-enable output type.

⁶³ Activated output is indicated by the LED "Ventilation". (Feedback from the fire ventilation equipment to a programmable input can instead light up the LED).

⁶⁴ Activated output is indicated by the LED "Extinguishing". (Feedback from the fire extinguishing equipment to a programmable input can instead light up the LED).

⁶⁵ Controlled by menu H2/B8 Disable / Re-enable Alarm devices and by push button "Silence alarm devices" on the control unit front. Output fault / disabled is indicated by LED **Fault / Disablements** "Alarm devices" blinking / continuous on.

⁶⁶ Activated according to its control expression (trigger cond. 21 *Indication Fire brigade tx activated* must **not** be used). Disabled like the standard control unit "Fire brigade tx" relay output. Activated output is indicated by the LED "Fire brigade tx". (Feedback from the Fire brigade tx to a programmable input can instead light up the LED). Output fault / disabled is indicated by LED **Fault / Disablements** "Fire brigade tx" blinking / continuous on.

NOTE! When the Alert Annunciation function shall be used the following trigger condition has to be added to the control expression:

&!Alert Annunciation activated. ("&!" is the same as "and not").

13.2 Logic

(•) **Normally open / low** Normally open relay contact or normally low voltage output.⁶⁷

() **Normally closed / high** Normally closed relay contact or normally high voltage output (24V DC).⁶⁸

13.3 Supervised / Not supervised

A voltage output is supervised (default). By unmarking the "Supervised" checkbox the voltage output will be not supervised.

A normally high output cannot be supervised.

13.4 Output signal period

Each output uses an "Output signal period", which controls the output's activation. The following are available:

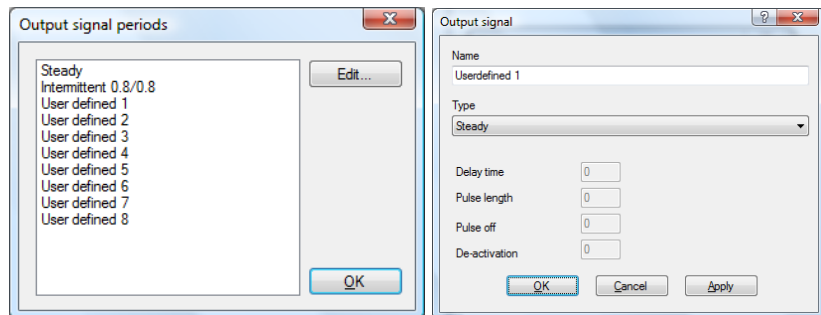

User defined 1-8 can be built up with type and time.

Types:

0. Steady (continuous)
1. Intermittent
2. Pulse
3. Steady, Delayed Activation
4. Intermittent, Delayed Activation
5. Pulse, Delayed Activation
6. Steady, Delayed De-Activation

Times:

- Delay time (when required)
- Pulse length time (when required)
- Pulse off time (when required)
- De-activation time (when required)

⁶⁷ The logic is set in the WinG3 dialog box "Voltage / Relayed Output".

⁶⁸ The logic is set in the WinG3 dialog box "Voltage / Relayed Output".

NOTE! A normally high output can not be supervised and it will be low for a few seconds during restart of the c.i.e.

Regarding the programming, see chapter "Output Signal Periods", page 141.

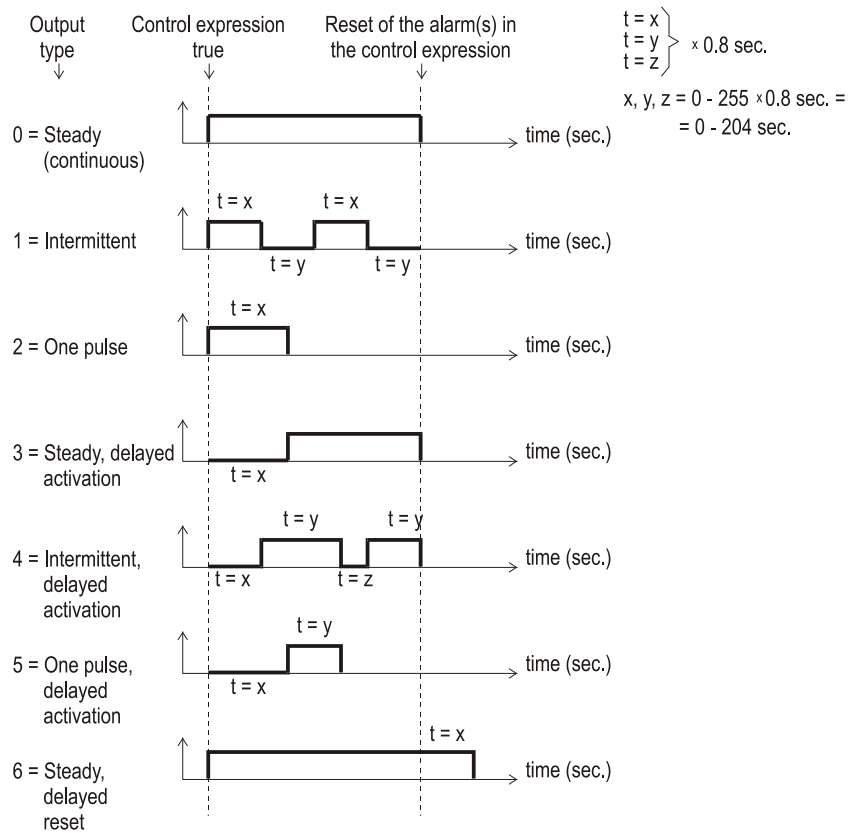

Figure 13. Delay time, Pulse length, Pulse off and/or De-Activation, have to be set for the type respectively.

NOTE! The different types can be used together with the different outputs according to the following table:

Output Type	In EBL512 G3				COM loop units				Inter locking
	S0-S3	R0, R1	4581 board	4583 board	I/O unit 3361	Unit 3364	Siren, S/B & Beacon 3377, 3379 & 4380	4582 board	
0 Steady (continuous)	X	X	X	X	X	X	X	X	X
1 Intermittent	X	X	XXX	--	--	XX	--	--	--
2 One pulse	X	X	XXX	--	--	--	--	--	--
3 Steady (continuous), delayed activation	X	X	X	X	X	X	X	X	X
4 Intermittent, delayed activation	X	X	XXX	--	--	XX	--	--	--
5 One pulse, delayed activation	X	X	XXX	--	--	--	--	--	--
6 Steady (continuous), delayed de-activation	X	X	X	X	X	X	X	X	--

*Figure 14. The types that can be used in the "Output signal period" for the programmable output respectively
X = Output type can be used. **XX** = Output type can be used but only 0.8s/0.8s. **XXX** = Output type can be used but max. 5.6s/5.6s and the pulse max. 5.6s respectively.*

13.5 Control expression

Each programmable output has to be given a control expression. It is created by so called Boolean algebra.

Trigger conditions (see "Available functions"), logical "Operators" (**AND**, **OR**, **NOT**) and parentheses are used to make a "control expression" containing up to 40 trigger conditions. See also chapter "Control expression examples" page 82.

A programmable output will be activated as long as its control expression is true.

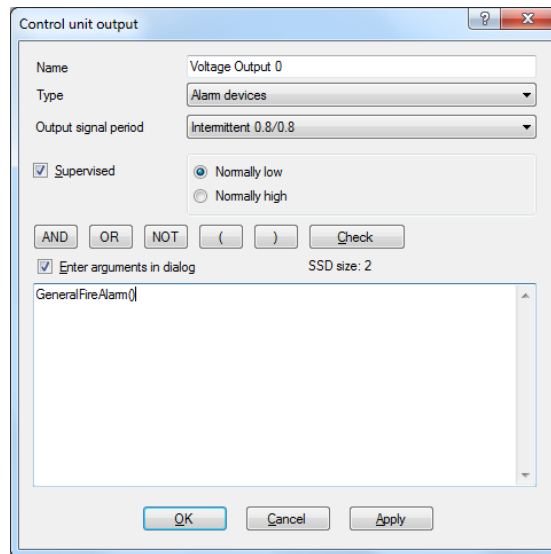

Figure 15. In any output dialog box, click the right mouse button in the large white field to show a "Trigger conditions list". Depending on the selected trigger condition, different arguments / data have to be entered. In the figure is the trigger condition "General Fire Alarm) selected.

13.5.1 Trigger conditions

Some trigger conditions require additional information, see information within parentheses (+nnnnn) after the trigger condition respectively below.

The following trigger conditions are available (numbering only for the comments below):

- 1 **Fire Alarm Zone** (+Zone no.)
- 2 **Fire Alarm Zone Address** (+Zone no.+Address)
- 3 **General Fire Alarm**
- 4 **Consecutive Fire Alarm** (sequence) (+start Zone no. and address +stop Zone no. and address +Quantity)
- 5 **Pre Warning Zone** (+Zone no.)
- 6 **Pre Warning Zone Address** (+Zone no.+Address)
- 7 **General Pre Warning**

-
- | | |
|----|---|
| 8 | Consecutive Pre Warning (+ <u>start</u> Zone no. and address
+ <u>stop</u> Zone no. and address +Quantity) |
| 9 | Heavy Smoke Alarm Zone (+Zone no.) |
| 10 | Heavy Smoke Alarm Zone Address (+Zone
no.+Address) |
| 11 | General Heavy Smoke Alarm |
| 12 | Consecutive Heavy Smoke Alarm (sequence) (+ <u>start</u>
Zone no. and address + <u>stop</u> Zone no. and address
+Quantity) |
| 13 | Two Address Dependent Fire Alarm (+Zone no.
+Address) |
| 14 | Two Zone Dependent Fire Alarm (+Zone no.) |
| 15 | Multiple Detector Alarm |
| 16 | One Detector Alarm |
| 17 | Interlocking Input Area Activated (+Area no.) |
| 18 | Interlocking Input Area Point Activated (+Area no.
+Point) |
| 19 | General Interlocking Input Activated |
| 20 | Consecutive Interlocking Input Activated (sequence)
(+ <u>start</u> Area no. and point + <u>stop</u> Area no. and point
+Quantity) |
| 21 | Indication Fire Brigade Tx Activated |
| 22 | Indication Fault Tx Activated |
| 23 | Fire Brigade Tx Disabled |
| 24 | Zone Disabled (+Zone no.) |
| 25 | Zone Address Disabled (+Zone no. +Address) |
| 26 | General Zone Address Disabled |
| 27 | General Fault |
| 28 | General Mains Fault |
| 29 | Reset Pulse Zone Address (+Zone no. +Address) ⁶⁹ |
| 30 | Time Channel Activated (+Time channel name / no.) |
| 31 | Alert Annunciation Activated |
| 32 | Alert Annunciation Acknowledged |
| 33 | Door Open |
| 34 | Key Cabinet Open |
| 35 | General Control Disabled |
| 36 | General Alarm Device Disabled |
| 37 | Fire Door Closing (+Zone no. +Address) |
| 38 | General Service Signal |
| 39 | Fire brigade Tx |
| 40 | Door Open Control Unit (+Control unit) |
| 41 | Control Disabled Control Unit (+Control unit) |
| 42 | Alarm Device Disabled Control Unit (+Control unit) |
| 43 | AAF Zone Alarm |
| 44 | Quiet Alarm Zone (+Zone no.) |
| 45 | Quiet Alarm Zone Address (+ Zone no. +Address) |

⁶⁹ Not valid for the 3364 outputs (VO0-VO2).

- 46 **Extinguishing System Fault**
- 47 **Extinguishing System Released**
- 48 **Activated Key Cabinet**

Comments to the trigger conditions (functions):

- 1 Fire alarm. For more information regarding fire alarm, see EBL512 G3 Operating Instructions MEW01349.
- 2 See 1.
- 3 See 1.
- 4 See 1. Quantity (1-10): "1" means one unit in alarm is required, "2" means two units in alarm are required to activate the output and so on.
- 5 Pre-warning.⁷⁰ For more information regarding pre-warning, see EBL512 G3 Operating Instructions MEW01349.
- 6 See 5.
- 7 See 5.
- 8 See 5. See also 4. above regarding "Quantity".
- 9 Heavy smoke / heat alarm. For more information regarding heavy smoke / heat alarm, see EBL512 G3 Operating Instructions MEW01349.
- 10 See 9.
- 11 See 9.
- 12 See 9. See also 4. above regarding "Quantity".
- 13 One address (in two-address dependence) is in fire alarm state. For more information, see EBL512 G3 Operating Instructions MEW01349.
- 14 One zone (in two-zone dependence) is in fire alarm state. For more information, see EBL512 G3 Operating Instructions MEW01349.
- 15 Output activated when "Multiple detector alarm" is true, i.e. fire alarm type A.⁷¹
- 16 Output activated when "One detector alarm" is true, i.e. fire alarm type B⁷¹.
- 17 One or more interlocking inputs, in the specified interlocking area, are activated.
- 18 The interlocking input, in the specified interlocking area/point, is activated.
- 19 One or more interlocking inputs are activated.
- 20 Interlocking inputs, in the specified range, are activated (from interlocking area no./point to interlocking area no./point). See also 4. above regarding "Quantity".

⁷⁰ The trigger condition is true as long as the pre-warning level is exceeded. It is also true as long as the fire alarm level is exceeded even if the option pre-warning detection is disabled (via WinG3).

⁷¹ See chapter "Fire alarm type A and Fire alarm type B", page 108.

- 21 Routing equipment output (any Fire brigade tx output) is activated.⁷²
- 22 Routing equipment output (Fault tx) is activated.⁷³
- 23 Routing equipment output (Fire brigade tx) is disabled.⁷⁴
- 24 The specified zone is disabled.
- 25 The specified alarm point (zone/address) is disabled.
- 26 One or more alarm points (zone/address) **and/or zones** are disabled.⁷⁸
- 27 One or more faults are generated in the system.⁷⁵
- 28 Loss of mains (in a c.i.e. or external power supply 3366).
NOTE! The output(s) will be activated immediately but the corresponding fault is normally delayed (set via WinG3).
- 29 This control expression is true for 5 seconds, whenever a reset pulse is sent to the specified zone/address. The control expression can only be used in the same c.i.e. as the specified zone/address.
- 30 The programmed time channel is activated.
- 31 Alert annunciation activated (by any alarm point set to activate this function).⁷⁶ For more information, see EBL512 G3 Operating Instructions MEW01349.
- 32 Alert annunciation activated (by any alarm point set to activate this function)⁷⁶ and acknowledged. For more information, see EBL512 G3 Operating Instructions MEW01349.
- 33 Door open in any control unit in the system.⁷⁷
- 34 General Key cabinet alarm activated. For more information, see EBL512 G3 Operating Instructions MEW01349.
- 35 This control expression is true when all control outputs of the types **Control, Fire ventilation** and **Extinguishing** in

⁷² Indicated by LED "Fire brigade tx". This output will also be activated when the routing equipment test is performed via menu H1. This trigger condition **must not** be used for type of output "Routing equipment (Fire brigade tx)".

⁷³ Indicated by LED **Routing equipment** "Fault tx activated". This output will also be activated when the routing equipment test is performed via menu H1.

⁷⁴ Indicated by LED **Fault/Disablements** "Fire brigade tx".

⁷⁵ Indicated by LED **Fault / Disablements** "General fault" and/or LED **Routing equipment** "Fault tx activated".

⁷⁶ Valid until the AA alarm is reset or becomes a normal fire alarm.

⁷⁷ Or ext FBPs connected to the control unit(s).

Indicated by the "Door open" symbol in the display symbol area.

- all control units are disabled via menu H2/B7.⁷⁸ This output shall be type Control – neutral.
- 36 This control expression is true when all control outputs of type **Alarm** device in all control units are disabled via menu H2/B8⁷⁹. This output shall be type Control – neutral.
- 37 This trigger condition plus the OR operator shall be used for each detector (zone-address) controlling a fire door (normally \geq two detectors). Type of output is normally "Control, neutral".⁸⁰ See also chapter "Fire Door Closing", page 90.
- 38 Service signal is activated (by any sensor).⁸¹
- 39 This control expression is true when the control unit standard output "Fire brigade tx" is activated. **NOTE!** Normally used with output type *Routing equipment (Fire brigade tx)*.
- 40 Door open in the specific control unit.⁷⁷
- 41 This control expression is true when all control outputs of the types **Control**, **Fire ventilation** and **Extinguishing** in the specified control unit are disabled via menu H2/B7.⁷⁸ This output shall be type Control – neutral.
- 42 This control expression is true when all control outputs of type **Alarm device** in the specified control unit are disabled via menu H2/B8). This output shall be type Control – neutral.
- 43 **Alarm Acknowledgement Facility. Australian facility (require special hardware). "Alarm" in any AAF zone is activated.**
- 44 Any "Quiet alarm" in the specified zone. Used e.g. for the fan control function.
- 45 One specified "Quiet alarm" in the specified zone. Used e.g. for the fan control function.
- 46 Output activated when input trigger condition "Extinguishing system fault" is true.
- 47 Output activated when input trigger condition "Extinguishing system released" is true.
- 48 Output activated when input trigger condition "Activated key cabinet" is true.

⁷⁸ Indicated by LED **Fault / Disablements** "General Disablements".

⁷⁹ Indicated by LED **Fault / Disablements** "Alarm devices".

⁸⁰ In Danish convention (DBI), must only the c.i.e. outputs R0-R1 and S0-S3 be used (i.e. no COM loop units.) and the type has to be "control neutral".

⁸¹ Indicated by a "Service" symbol in the display symbol area.

13.5.2 Logical operators

The logical operators available in WinG3 are in priority order:

() **parentheses**, changes priority order

NOT **not**-function (inverts), is written NOT in WinG3

AND **and**-function, is written AND in WinG3

OR **or**-function, is written OR in WinG3

13.5.3 Control expression examples

In order to understand the possibilities to create control expressions, here follow some AND, OR, NOT and () examples and also some control expression examples.

13.5.3.1 AND

a AND b AND c=y

y is true (=1) when all the conditions **a**, **b**, **c** are true, i.e. a=1 and b=1 and c=1 makes y=1. All other combinations makes y=0.

This is also shown in the following table:

a	b	c	y
0	0	0	0
0	0	1	0
0	1	0	0
0	1	1	0
1	0	0	0
1	0	1	0
1	1	0	0
1	1	1	1

13.5.3.2 OR

a OR b OR c=y

y is true if at least one of the conditions **a**, **b**, **c** is true, i.e. a=1 or b=1 or c=1 makes y=1.

This is also shown in the following table:

a	b	c	y
0	0	0	0
0	0	1	1
0	1	0	1
0	1	1	1
1	0	0	1
1	0	1	1
1	1	0	1
1	1	1	1

13.5.3.3

NOT

Inverts a condition, e.g. $NOT\ b = NOT\ 0=1$.

$a\ OR\ NOT\ b\ AND\ c = y$

This is shown in the following table:

a	b	c	y
0	0	0	0
0	0	1	1
0	1	0	0
0	1	1	0
1	0	0	1
1	0	1	1
1	1	0	1
1	1	1	1

13.5.3.4

Parentheses

Changes priority order.

$a\ OR\ NOT(b\ AND\ c) = y$ (This is same as the previous but completed with parentheses.)

This is shown in the following table:

a	b	c	y
0	0	0	1
0	0	1	1
0	1	0	1
0	1	1	0
1	0	0	1
1	0	1	1
1	1	0	1
1	1	1	1

13.5.3.5 Control expressions

The AND operator has priority, i.e. $a \text{ AND } b \text{ OR } c = (a \text{ AND } b) \text{ OR } c$.
This is perhaps more obvious if you write it: $a \cdot b + c$.
This means that: $a \text{ AND } b \text{ OR } c \neq a \text{ AND } (b \text{ OR } c)$.

Here follows some examples (and explanations) to show the principles how to build a control expression with "conditions" and logical operators.):

Example 1

Output: Voltage output **S0**
Control expression: Pre Alarm Zone (90)
Explanation: Pre-warning activated in zone no. 90 will activate the output S0.

Example 2

Output: Relay output **R1**
Control expression: General Control Off () **AND NOT** Door Open (01)
Explanation: Controls OFF (via menu H2/B8) will activate the output R1 when the door in control unit 01 is not open (i.e. closed).

Example 3

Output: Relay output **R0**
Control expression: Fire Alarm Zone (145) **AND** Fire Alarm Zone (045) **AND** General Fault ()

Explanation: Fire alarm activated in zone 145 and zone 45 will activate the output R0 when there are one or more faults in the system at the same time.

Example 4

Output: Voltage output **S1**

Control expression: Consecutive Fire Alarm (100,10,100,19,1)
OR
Consecutive Fire Alarm (100,21,100,40,1)

Explanation: Fire alarm activated by one of the alarm points in zone 100 address 10-19 or activated by one of the alarm points in zone 100 address 21-40 will activate the output S1 (i.e. alarm point address 20 in zone 100 will not activate the output S1).

14 Interlocking function

The interlocking function is used to verify that an output really is activated, i.e. by "combining" an output with an input (feed-back from the equipment controlled by the corresponding interlocking output).

14.1 Programming of interlocking function

WinG3 is used for the programming. Up to 200 Interlocking Combinations per c.i.e. can be used and up to 1000 in a system.

NOTE! One Interlocking Combination (the input, the output and the area) has to be in / connected to one c.i.e. An input and an output can only be used in one combination.

14.1.1 Interlocking output

The "Voltage Output" / "Relay Output" dialog boxes are used.

Type: "Interlocking" shall be selected.

Output signal period: Type Steady (continuous) or Type Steady, delayed activation can be selected (checked by the "Validate" function in WinG3).

A **Control Expression** shall be programmed for the output, i.e. for the equipment to be controlled.

Activated output will be indicated in menu H9/C1.

Name: The interlocking combination's presentation number (Area-Point) could be added.

14.1.2 Interlocking input

The "Input" dialog box is used.

Type "Interlocking" shall be selected.

Activated input will be indicated in menu H9/C1.

Name: The interlocking combination's presentation number (Area-Point) could be added.

14.1.3 Interlocking combination

One interlocking output and one interlocking input are programmed in an interlocking combination to get the interlocking functions.

NOTE!

The interlocking outputs and inputs have to be programmed before the programming of an interlocking combination is possible to do.⁸²

(An interlocking combination can have only an output or only an input programmed, e.g. when a user definable text message is wanted to indicate an activated output or input.)

⁸² In the "Interlocking Combination" dialog box are listed all the outputs and inputs previous programmed for interlocking, see Figure 16.

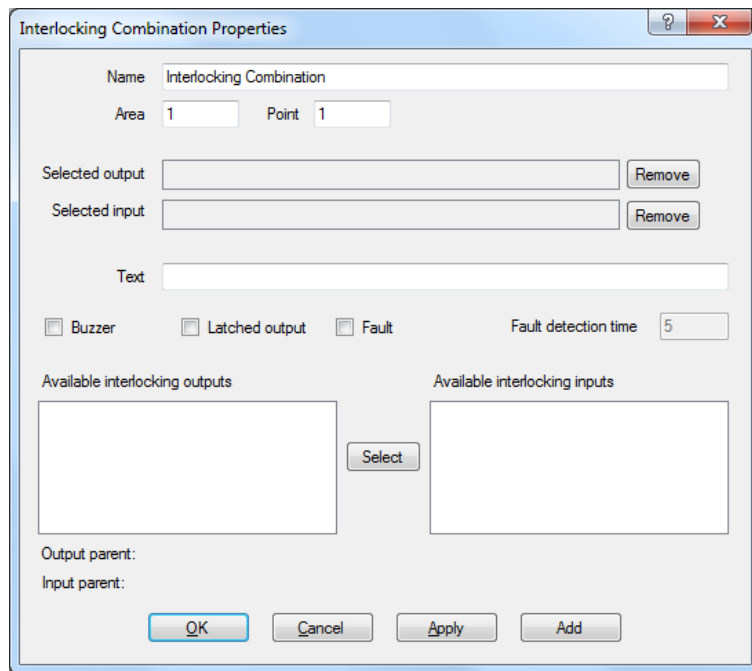

Figure 16. WinG3 "Interlocking Combination" dialog box.

Name: Displayed in the WinG3 Tree and List views. Default is "Interlocking Combination" that can be edited when wanted / required. "Area-Point" will be added in the tree view. "Area-Point" will be shown under "Zone-Address" in the list view.

The **Available interlocking outputs** list displays all the previous programmed outputs, Type = "Interlocking".

The **Available interlocking inputs** list displays all the previous programmed inputs, Type "Interlocking". Select one **Output** and one **Input**. Press **Select** and the selected output and input will be shown in the **Selected output** and **Selected input** field respectively.

It is possible to **Remove** an output / input (from the field).

Output parent: Shows where the selected output is situated, e.g. Control unit 0.

Input parent: Shows where the selected input is situated, e.g. Control unit 0.

Area and Point: Each "Interlocking Combination" is presented as Area-Point (compare with Zone-Address). Area numbers 1-999 are possible and within each Area, Point numbers 1-99 are possible to use. An Area can only be used in one c.i.e.

Text = User definable text message to be shown in the menu H9/C1. Can be written in this field or in the "Texts" dialog box, see chapter "Creating the alarm texts via WinG3", page 113.

Buzzer checked = activated interlocking input will turn on the c.i.e. buzzer (0.8 / 0.8 sec.)⁸³. The buzzer can be silenced. It will be automatically turned on again, if a new interlocking input is activated.

Latched output checked = Output reset has to be performed via menu H9/C3. (Automatically output reset will not take place when the control expression becomes false.).

Fault checked = Fault detection ON.

Fault Detection Time: If the input is not activated within 5-255 seconds after the output is activated⁸⁴, a fault will be generated:

FAULT: Interlocking input AAA/PP

14.2 Interlocking indications

One or more activated Interlocking Combinations (interlocking output and/or input) are listed in the c.i.e. display⁸⁵:

Disabled interlocking output is indicated by the LED "Disablesments".

14.3 Information of interlocking combinations (H9)

Menu H9 has the following sub menus.

14.3.1 Display interlocking information (H9/C1)

See also chapter "Interlocking indications", page 88.

In menu H9/C1 will information be shown as follows:

```
Interlocking area AAA point PP output active
User definable text message..
yyyy-mm-dd hh:mm
```

or

```
Interlocking area AAA point PP input/output active
User definable text message..
yyyy-mm-dd hh:mm
```

or

```
Interlocking area AAA point PP input active
User definable text message..
yyyy-mm-dd hh:mm
```

AAA = Interlocking combination Area

PP = Interlocking combination Point within the Area

Date (yyyy-mm-dd) and time (hh:mm).

Use "↑" "↓" to scroll between several interlocking combinations.

⁸³ Priority order: Fire alarm – Pre-warning - Interlocking - Fault.

⁸⁴ After the end of the any delay time.

⁸⁵ This indication has the lowest priority and will only be shown if the display was empty.

14.3.2 **Activate interlocking output (H9/C2)**

Even if the control expression for an interlocking output is not fulfilled (true), the output can be manually activated via this menu.

The "Interlocking Combination" (Area / Point) is to be entered to activate the output. The corresponding interlocking input will be "monitored" in the same way as if the output was activated by its control expression.

Reset has to be performed via menu H9/C3.

14.3.3 **Reset interlocking output (H9/C3)**

Activated interlocking outputs are listed here. Use "↑" "↓" to scroll between the "Interlocking Combinations" (Area / Point).

Interlocking output activated via its control expression and latched output selected: The output has to be reset via this menu.

Interlocking output activated via its control expression and latched output not selected: The output can be reset via this menu.

Interlocking output activated via menu H9/C2: The output has to be reset via this menu.

14.3.4 **Disable interlocking output (H9/C4)**

Interlocking outputs (i.e. Output Type = Interlocking) can be individually disabled via menu H9/C4. **NOTE!** Not via menu H2/B3. A disabled output will stay in (or return to) the normal condition for the output respectively. The "Interlocking Combination" (i.e. Area / Point) is to be entered to disable the output.

Via menu H2/B7 can all interlocking outputs in the system be disabled / re-enabled.

14.3.5 **Re-enable interlocking output (H9/C5)**

Interlocking outputs (i.e. Output Type = Interlocking) can be re-enabled via menu H9/C5. **NOTE!** Not via menu H2/B6.

Disabled interlocking outputs are listed in menu H9/C5. Use "↑" "↓" to scroll between the "Interlocking Combinations" (i.e. Area / Point) or type it via the key-pad.

14.4 **Interlocking control expressions**

A programmable output control expression can contain "interlocking" trigger conditions ("Functions") numbers 15-18 (see chapter "Control expression", page 77), i.e. one or more outputs can be activated when one or more interlocking inputs are activated.

15 Fire Door Closing

Programmable outputs can be used for fire door closing.⁸⁶ A special trigger condition is available (Fire Door Closing.). Type of output is normally "Control, neutral". One or more alarm points can control the output, i.e. the detectors on both sides of the fire door.

NOTE! The alarm points and their "belonging" output have to be in / connected to the same c.i.e.

In case of one of the following "events", the output will be activated, i.e. the fire door will close:

- Fire alarm (any of the detectors controlling the fire door)
- Fire alarm in "Test mode" (any of the detectors controlling the fire door)
- Fault (i.e. "no answer" from any of the detectors controlling the fire door⁸⁷)
- Disablement (any of the detectors controlling the fire door, the zone(s) involved or the COM loop involved)⁸⁸
- A definite time every day, if programmed via WinG3. The output will be activated for 20 seconds.
- Via a programmable input (trigger condition "Door Closing Test Input"). The output will be activated for 20 seconds. The input has to be in / connected to the same c.i.e. as the alarm points and their "belonging" output.

NOTE!

Zone line inputs (via 4580) cannot be used for this type of Fire Door Closing.

If a magnet contact is available, is it possible to get a "closed fire door verification" via the Interlocking function. In this case, Type of output has to be "Interlocking output". See also chapter "Interlocking function", page 86.

⁸⁶ In the DBI (Danish) convention, must only the c.i.e. outputs R0-R1 and S0-S3 in the c.i.e. be used. **Also the COM loop unit Addressable 2 voltage outputs unit 3364 can be used.** "Type of output" has to be "Control, neutral".

⁸⁷ E.g. if the detector is faulty, if there are two breaks or short-circuit on the COM loop.

⁸⁸ If an I/O unit 3361 output is used, it is recommended, for safety reasons, to **not** connect it to the same COM loop as the detectors controlling the fire door.

16 Functions / Services / Features

Some Functions / Services / Features require programming in WinG3, see chapter "PC software (S/W)", page 16.

How to connect the PC and for more information, see EBL512 G3 Operating Instructions MEW01349 chapter "Programming (SSD download)", "New system program (S/W) version download", *etc.*

16.1 Sensor value

An analog smoke detector is like a "sensor". It detects its environment at all times. Each detected analog value is, in the detector, converted to a digital "**sensor value**", which for each individual detector, is continuously picked up and evaluated by EBL512 G3. In Figure 17 the (digital) sensor values (during a certain time) are represented by the graph "**Working level**".

16.2 Week average sensor value

Each hour, one sensor value is stored in a special memory (in EBL512 G3) and each week, these stored sensor values are used for a "**week average sensor value**" calculation.⁸⁹ This is done for each analog smoke detector individually. In Figure 17 the (digital) week average sensor values (during a certain time) are represented by the graph "**Week average sensor value**" (B).

Each analog smoke detector has a default sensor value = 1 and a week average sensor value = 1 (i.e. at Time = 0).

A "**fire alarm offset**" (value) is added to the week average sensor value to get each detector's "**Fire alarm level**", i.e. the fire alarm level will be adjusted in relation to each new week average sensor value in order to keep the detector's fire alarm sensitivity constant. The fire alarm level is in Figure 17 represented by the graph "**Fire alarm level**" (C) - parallel with the graph "**Week average sensor value**" (B).

In Figure 17 (at Time = 0):

The week average sensor value (B) is 1 (=0.1 %/m) and the fire alarm offset is 3 %/m, i.e. the fire alarm level (C) is $0.1+3=3.1$ %/m.

Service signal will be given when the week average sensor value for a detector has reached the service signal level (1.8 %/m), i.e. the detector is "dirty" and has to be replaced. See "**Service level**" (D) in Figure 17. The week average sensor value will now stay on 1.8 %/m, i.e. the detector will be more sensitive until it is replaced with a new one.

⁸⁹ The week average sensor value will be calculated within 2 minutes after any restart, i.e. also after SSD download. During these "2 min." all analog smoke detector fire alarms are suppressed.

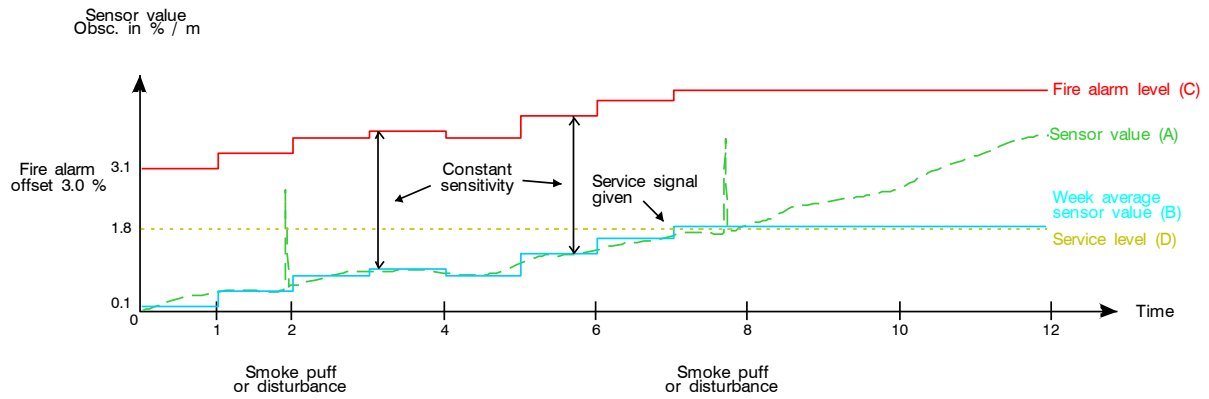

Figure 17. The basic working **principle** for an analog smoke detector ("sensor"). Sensor value (A), Week average sensor value (B), Fire alarm offset (3 %/m), Fire alarm level (C) and Service level (D).

"Sensor Information" is available via menu H4/U4. Via WinG3 and a PC connected to EBL512 G3 you can get "Sensor Information" for all analog detectors on a COM loop or an individual detector. For an individual detector you can also get continuous information:

Technical no. | Zone-Address | Min. | Max. | Momentary | Weekly | Performance factor.

Also via the Web-server II 1598 you can get "Sensor Information" for all analog detectors on a COM loop.

The smoke detector sensor values are presented as obscuration in % per meter (%/m). (Heat detector values as °C.)

16.3 Decision value

In order to secure real fire alarms and reduce the nuisance alarms, a decision value is calculated. The decision value is used to decide if it is normal state, pre-warning, fire alarm or heavy smoke alarm and also in the smouldering smoke algorithm (see page 96). The decision value is calculated, see chapter "Filtering algorithm, page 94.

16.4 Alarm algorithms for smoke detectors / Detection levels / Offsets

Each alarm algorithm has three detection levels:

1. **fire alarm** (fire alarm level = the week average sensor value + the fire alarm offset)
2. **pre-warning** will be activated (if selected in WinG3 – Control unit Properties) at a lower level (smaller offset) than for fire alarm, i.e. pre-warning will be activated before the fire alarm from the same alarm point.
3. **heavy smoke alarm** will be activated at a higher level (bigger offset) than for fire alarm, i.e. heavy smoke alarm will be activated later than the fire alarm from the same alarm point.

The pre-warning offset and the heavy smoke alarm level can, for the whole system, be set in WinG3, see chapter "Alarm algorithms", page 139.

The fire alarm offset can, for the whole system, be set in WinG3, see chapter "Alarm algorithms", page 139.

NOTE! This is not a normal action and a special password is required. "Pre-warning", "Fire Alarm" and "Heavy Smoke Alarm" can activate programmable outputs respectively, see chapter "Control expression", page 77. See also EBL512 G3 Operating Instructions MEW01349.

16.4.1

Alarm algorithm / Alternative alarm algorithm

In order to reduce the nuisance alarms⁹⁰ and ensure that the real fire alarms will be activated, six different alarm algorithms are available. See Figure 18., page 94. They are based on:

- Normal (N), High (H) or Low (L) sensitivity
- Normal (15 sec.) or slow (35 sec.) detection time

Normal sensitivity (Default) Fire alarm offset is **3.0 %** smoke obscuration per meter.

High sensitivity Fire alarm offset is **2.4 %** smoke obscuration per meter, i.e. less than for normal sensitivity. Can be used when an "early" fire alarm is wanted.

Low sensitivity Fire alarm offset is **3.6 %** smoke obscuration per meter, i.e. more than for normal sensitivity. Can be used to reduce nuisance alarms⁹⁰ but might not fulfil the EN54-7 specifications.

Normal detection time - 15 sec. (Default) There will always be min. 15 seconds alarm delay⁹¹. This is a "normal filter" to reduce nuisance alarms.

Slow detection time - 35 sec. There will always be min. 35 seconds alarm delay⁹¹. This is an "extra filter" to reduce nuisance alarms⁹⁰ but might not fulfil the EN54-7 specifications.

Each analog smoke detector can have two alarm algorithms programmed (via WinG3). One **Regular alarm algorithm** that is normally used (**N-15** is default) and one **Alternative alarm algorithm** that is turned on/off via a time channel (internal or external). E.g. normal sensitivity can be used during night-time and low sensitivity during daytime (i.e. the alternative alarm algorithm is used to reduce nuisance alarms⁹⁰ during working hours).

The alarm algorithm in use can be read in menu H4/U4.

The alarm algorithm parameters can, for the whole system, be set in WinG3, see chapter "Alarm algorithms", page 139 and WinG3 help. (To change some parameters a special password is required.)

⁹⁰ So called false / unnecessary alarms.

16.4.2 Filtering algorithm

In order to secure a fast detection of real fire alarms and to reduce nuisance (false) alarms to a minimum, a filtering algorithm is used.

The filtering algorithm uses the sensor values to calculate a decision value depending on which alarm algorithm that is in use. The decision value is zero from the beginning. Each time a new sensor value is picked up (sampled) from an analog smoke detector 430x, this new sensor value is compared with the actual decision value and the decision value will be adjusted or not adjusted as follows:

If the difference, between the new sensor value and the actual decision value is \leq "X", the decision value is set equal to the new sensor value.

If the difference is $>$ "X", the decision value is increased or reduced by "X".

"X" = The Step Value. It is different depending on the sensitivity and detection time, i.e. it is depending on the selected alarm algorithm, see Figure 18.

The decision value will consequently not be increased / decreased with a value exceeding the "X" value even if the sensor values are much higher / lower.

Analog detector	Normal detection time (15sec.)			Slow detection time (35sec.)		
	H-15 2.4%, High sensitivity	N-15 3.0%, Normal sensitivity	L-15 3.6%, Low sensitivity	H-35 2.4%, High sensitivity	N-35 3.0%, Normal sensitivity	L-35 3.6%, Low sensitivity
4300 / 4301	X=8	X=10	X=12	X=4	X=5	X=6

Figure 18. The six alarm algorithms. Default is alarm algorithm N-15, i.e. normal detection time (15 sec.) and normal sensitivity (3%). X=The step value. (The L-15, H-35, N-35 and L-35 algorithms might not fulfil the EN54-7 specifications.)

⁹¹ After the fire alarm level is reached / passed, it will take min. 15 alt. 35 seconds until fire alarm will be activated in the c.i.e.

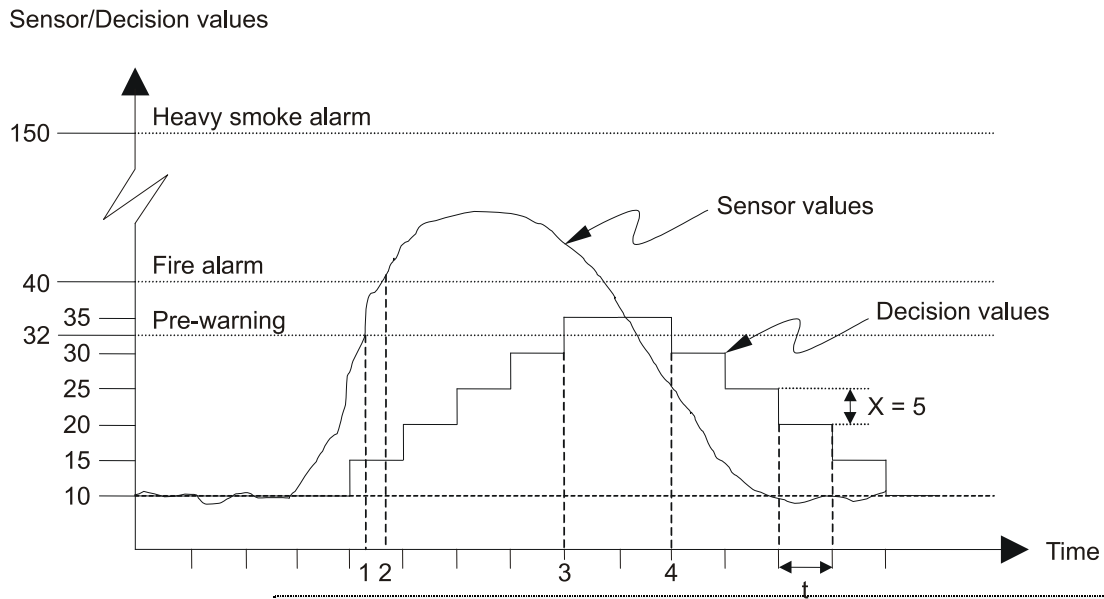

Figure 19. An example of the filtering algorithm for an Analog smoke detector with the step value $X = 5$. The polling time (t) in this example is approx. 2.56 seconds.

Explanations to the figure:

In this example, the week average sensor value is "10" at the "starting point", i.e. due to contamination the pre-warning level has been adjusted to "32" ($10+22$) and the fire alarm level to "40" ($10+30$). The sensor value is accordingly "10".

In this example, alarm algorithm "N-15" is selected, i.e. normal detection time 15 sec. and normal sensitivity 3% (30). $X = 5$. The detector polling time $t \approx 2.56$ sec. (In system EBL512 G3 the detector polling time $t \approx 6$ seconds and the step value "X" is according to Figure 18 – but the principle is the same.)

At start the sensor values and decision values are approx. equal ("10"). When smoke comes into the detector the sensor values are increasing and by the fourth polling approx. "27". Since $27-10 > X=5$, the decision value ("10") is increased by $X=5$ to "15". Next polling the sensor value is approx. "45", i.e. the decision value ("15") is increased by $X=5$ to "20", and so on. In this example the decision value never comes up to the fire alarm level. When the sensor value is reduced to approx. "25" the decision value is set to "30", because $35-25=10 > X=5$, i.e. the decision value ("35") is reduced by $X=5$ to "30", and so on.

1. The sensor value has here reached the pre-warning level but nothing will happen since the decision value has not reached the pre-warning level.
2. The sensor value has here reached the fire alarm level but nothing will happen since the decision value has not reached the fire alarm level.

3. The decision value has here reached the pre-warning level and pre-warning is activated.
4. The decision value is here below the pre-warning level and the pre-warning is automatically reset.

16.4.3 Smouldering smoke algorithm

The smoke from a smouldering fire brings the sensor value to rise very very slowly but not reach the fire alarm level. A smouldering fire can last for hours and sometimes days. The smouldering smoke algorithm will detect such a fire at an "early" stage.

The smouldering smoke algorithm is depending on and works in parallel with the selected alarm algorithm, i.e. the smouldering smoke algorithm can affect the pre-warning and fire alarm levels, see below.

If the decision value has been over the smouldering level for **7 minutes** (1-2 in the figure), the pre-warning and fire alarm levels will be lowered:

- The pre-warning level will be lowered to a level right between the original pre-warning level and the smouldering level.
- The fire alarm level will be lowered to a level right between the original fire alarm level and the pre-warning level.

If the decision value has reached the pre-warning level, but not the fire alarm level, after **additional 90 minutes** (2-4 in the figure), the pre-warning and fire alarm levels will be lowered again:

- The pre-warning level will be lowered to the original smouldering level.
- The fire alarm level will be lowered to the original pre-warning level.

If the decision value continue to rise fire alarm will be activated (5 in the figure).

The smouldering smoke algorithm will be aborted and the pre-warning and fire alarm levels restored to their original values if:

- The decision value becomes lower than the smouldering level.
- The decision value, after the **90 minutes**, has not reached the pre-warning level.
- The decision value, after the **90 minutes** and **additional 120 minutes**, has not reached the fire alarm level.

The smouldering offset can, for the whole system, be set in WinG3, see chapter "Alarm algorithms", page 139.

Sensor/Decision values

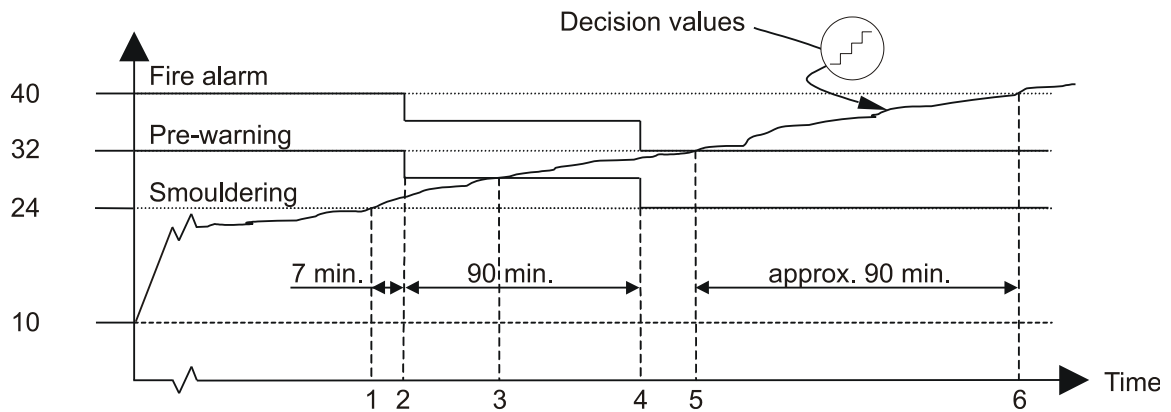

Figure 20. An **example** of the smouldering smoke algorithm for an Analog smoke detector 4301.

Explanations to the figure:

In this example, the week average sensor value and the decision value are "10" at the "starting point", i.e. due to contamination the smouldering level has been adjusted to "24" (10+14), the pre-warning level to "32" (10+22) and the fire alarm level to "40" (10+30).

When a smouldering fire starts, the sensor values and the decision values will increase slowly upwards from "10".

1. The decision value has here reached the smouldering level. A 7 minutes timer is started.
2. After the 7 minutes the decision value is still over the smouldering level and the pre-warning level and the fire alarm level are lowered. A 90 minutes timer is started.
3. The decision value has here reached the pre-warning level and pre-warning is activated.
4. After the 90 minutes the decision value is still over the pre-warning level but has not reached the fire alarm level. The pre-warning level and the fire alarm level are lowered again. A 120 minutes timer is started.
5. The decision value has here reached the fire alarm level and fire alarm is activated.
6. The decision value has here reached the original fire alarm level, i.e. the fire alarm would have been activated approx. 90 minutes later than with the smouldering algorithm!

16.5 Performance factor

To find out how the environment is where an analog smoke detector 430x is mounted, the **performance factor** can be studied. The performance factor is shown in menu H4/U4 together with the min.

and max. sensor values. All three values should be studied together. (E.g. one or two high sensor values will not result in a high performance factor.) The performance factor is calculated for each detector individually.

$$\frac{\sum_{m=0}^{14400} |X_m - X_{wa}|}{14400} = Pf$$

X_m = momentary sensor values for 24 hours.
 X_{wa} = weak average sensor value
14400 = pollings during 24 hours

Each sensor value is compared with the week average sensor value. The absolute difference is saved and each twenty-four hour (at midnight) is an "average value" calculated, i.e. the performance factor.

If the detector is mounted in a very "stable" environment, the performance factor will be low (min. 0 %/m).

If the detector is mounted in a very "unstable" environment, the performance factor will be high (max. 2.55 %/m).

An "unstable" environment can cause nuisance alarms (unnecessary alarms). Perhaps should another type of detector or alarm algorithm be used or other functions, e.g. alert annunciation or two-address dependence.

16.6

Algorithms for analog heat detectors

The detectors conforms to a class (see EN54-5:2000, clause 4.2) according to the requirements of the tests specified in EN54-5:2000, clause 5.

Each analog heat detector can have two alarm algorithms programmed (via WinG3). One **Regular alarm algorithm** that is normally used and one **Alternative alarm algorithm** that is turned on/off via a time channel (internal or external). E.g. class A1 can be used during night-time and class B can be used during daytime (the alternative alarm algorithm is used to reduce nuisance alarms during working hours). The actual algorithm can be read in menu H4/U4.

When the c.i.e. has picked up a sensor value above the **fire alarm** level (xx° C) for a detector, the next two values from the same detector also have to be above the fire alarm level to activate fire alarm in the c.i.e. (This results in an approx. 5 seconds alarm delay).

The same is valid for **pre-warning** except it is a lower level (xx° C) than for fire alarm. (If pre-warning shall be generated or not, is selected in WinG3 – System Properties).

The same is valid for **heavy heat alarm** except it is a higher level than for fire alarm.

The fire alarm, pre-warning and heavy heat alarm levels can, for the whole system, be set in WinG3, see chapter "Alarm algorithms", page 139.

See EBL512 G3 Operating Instructions MEW01349 for more information.

16.6.1

Class A1 algorithm

Conforms to Class **A1**.

Typical / max. application temperature 25 / 50° C.

Max. / min. static response temperature 54 / 65° C.

The algorithm is as follows:

For a rate-of-rise $\leq 4^\circ$ C per minute:

Fire alarm level is 56° C.

Pre-warning level is 46° C.

Heavy heat alarm level is 90° C.

Rate-of-rise $> 4^\circ$ C per minute:

Fire alarm level is 46° C.

Pre-warning level is 36° C.

Heavy heat alarm level is 90° C.

The "Class A1 algorithm" will detect a fast temperature rise (rate-of-rise $> 4^\circ$ C per minute) some minutes earlier than the "Class A2 algorithm".

16.6.2

Class A2 S algorithm

Conforms to Class **A2 S**.

Typical / max. application temperature 25 / 50° C.

Max. / min. static response temperature 54 / 70° C.

The algorithm is as follows:

Fire alarm level is 60° C).

Pre-warning level is 50° C.

Heavy heat alarm level is 90° C.

16.6.3

Class B S algorithm

Conforms to Class **B S**.

Typical / max. application temperature 40 / 50° C.

Max. / min. static response temperature 69 / 85° C.

The algorithm is as follows:

Fire alarm level is 74° C.

Pre-warning level is 64° C.

Heavy heat alarm level is 90° C.

The "Class B S algorithm" can be used when the application temperature is "high" (compare with the "Class A1 an A2 S algorithms).

16.7

Self verification

The analog detectors 430x (in NORMAL mode) have a built-in self verification function. The detector's HW is always supervised by the detector's S/W and CPU. Every minute, each detector will receive a question from the c.i.e. If the self verification function has detected any fault it will be reported back to the c.i.e. A fault will be activated in the system and the following fault message will be shown:

FAULT: Loop unit xxx-xx
Technical number xxxxxx

16.8 Minimum / Maximum sensor values

To find out how the environment is, where an analog detector 33xx / 430x (in NORMAL mode) is mounted, the **minimum and maximum sensor values** can be studied. The sensor values are continuously picked up and evaluated by the control unit (c.i.e.) for each detector individually. Every value is checked if it is a new minimum or maximum value for that detector. At midnight every day a memory will be updated and the new minimum and maximum sensor values can be read in menu H4/U4⁹².

For analog smoke detectors the minimum and maximum sensor values are shown as XX.X % (obscuration) per meter.

For analog heat detectors the values are shown as XX°C.

⁹² I.e. the min. / max. sensor values shown, are from the previous day.

16.9 2-zone / 2-address dependence (Co- incidence alarm)

In some premises 2-zone or 2-address dependent fire alarm ("Two unit dependent" in WinG3) can be used to avoid unwanted / false alarms (nuisance alarms). A time channel can turn on/off this function.

16.9.1 2-zone dependence

Each zone in the system can be programmed to be "Two zone dependent" for fire alarm activation. The zone has to belong to one of ten "Two zone dependent" groups (1-10).⁹³

Function:

Two or more zones in the same group have to be in "fire alarm state"⁹⁴ at the same time to activate fire alarm in the control unit. When only one of the zones is in "fire alarm state" it is indicated in the control unit (c.i.e.) as follows:

- The buzzer sounds like for pre-warning (0.8 / 5 sec.).
- In the c.i.e. LCD the following information is shown:

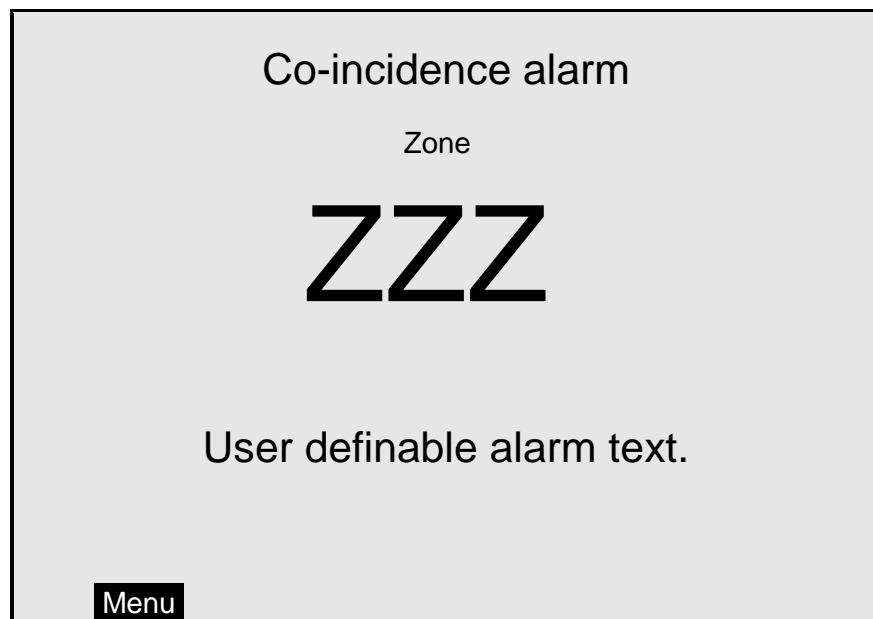

Programmable outputs can be activated by trigger condition "Two Zone Dependent Fire Alarm" but no other outputs will be activated.

⁹³ See also chapter "Two zone dependence", page 143.

⁹⁴ Fire alarm state is when a fire alarm normally would have been activated in the c.i.e.

16.9.2 2-address (-unit) dependence

Each analog detector, addressable multi purpose I/O unit (3361) monitored Input 0 (Z) and 8 zones expansion board (4580) input, can be programmed for 2-unit dependent fire alarm activation. (Heat detectors should not and manual call points must not be 2-unit dependent).

Function:

Two or more units in the same zone have to be in "fire alarm state"⁹⁴ at the same time to activate a fire alarm in the control unit. When only one unit is in "fire alarm state" it is indicated in the control unit (c.i.e.) as follows:

- The buzzer sounds like for pre-warning (0.8 / 5 sec.).
- In the c.i.e. LCD the following information is shown:

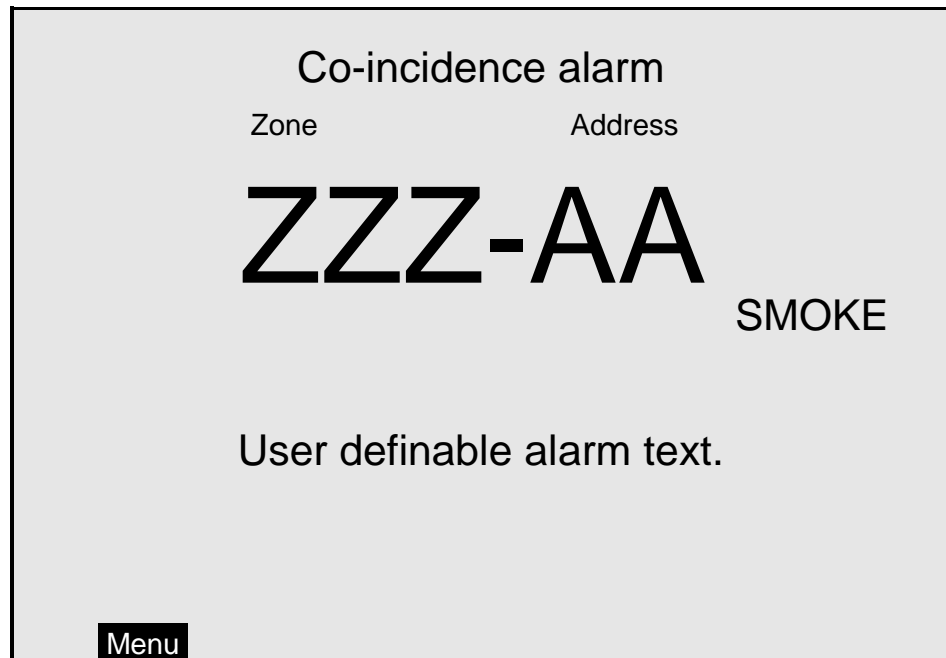

Programmable outputs can be activated by trigger condition "Two Address Dependent Fire Alarm" but no other outputs will be activated.

16.9.3 Reset of 2-zone / 2-address dependence (co-incidence alarm)

The unit / zone having activated a Co-incidence alarm will be latched in this status for at least 5 minutes and then automatically reset. During these 5 minutes the push button "Reset", on the c.i.e. front / FBP, can be used to manually reset the Co-incidence alarm.

If, during these 5 minutes, at least one more unit (in the zone) or at least one more zone (in the group) comes into "fire alarm state", the Co-incidence alarm ends and normal fire alarms will be activated in the c.i.e.

16.10 Delayed alarm

In some premises delayed fire alarm activation can be used to avoid unwanted false alarms (nuisance alarms). The delay time will be added at the end when a fire alarm normally would have been activated in the c.i.e. This function is a violation to the EN54-2 standard.

Each analog or addressable detector, each addressable multipurpose I/O unit (3361) monitored input (Z) and 8 zones expansion board (4580) input in the system can be programmed (in WinG3) to delayed fire alarm activation. (Heat detectors should not and manual call points must not have delayed fire alarm activation). The delay time can be set (in WinG3, System Properties) to 0-255 seconds.⁹⁵

Function for an analog or addressable smoke detector:

An alarm point has to be in "fire alarm state"⁹⁴ all the delay time, in order to activate a fire alarm in the c.i.e. If an alarm point goes back to "normal state" during the delay time, the delay time will be reset and start again if/when the alarm point comes in "fire alarm state" again.

Function for each addressable multipurpose I/O unit (3361) monitored Input 0 (Z) and 8 zones expansion board (4580) input:

A zone in "fire alarm state" will be recorded in the c.i.e. but fire alarm will not be activated. When the delay time has run out the zone will be automatically reset and if it still is in "fire alarm state" a fire alarm will now be activated in the c.i.e.

16.11 Selective Alarm Presentation

Instead of having all fire alarms presented in all control units (default) it is possible to have Selective Alarm Presentation, i.e. only fire alarms from selected control units will be presented in the control unit respectively. This selection is done in WinG3 for the control unit respectively.

16.12 Alarm Verification Facility

In some premises AVF can be used to avoid unwanted false alarms (nuisance alarms). Note, this function is a violation to the EN54-2 standard.

This function is valid for any zone line input but only in the Australian and New Zealand convention respectively.

In these conventions the function "Delayed alarm" (see above) is not valid.

The function "Delayed" is selected in the dialog box for the zone line input respectively.

⁹⁵ Default is 0 seconds and a recommended delay time is ≤ 30 seconds.

Function: A zone in "fire alarm state"⁹⁶ will be recorded in EBL512 G3 but a fire alarm will not be activated. After 15 seconds the zone will be automatically reset. If the zone comes in "fire alarm state" again within 110 seconds a fire alarm will be activated in EBL512 G3, else nothing will happen until the next time the zone is in "fire alarm state" and so on.

16.13 Alert Annunciation

In some installations the Alert Annunciation function can be used to avoid unwanted false alarms (nuisance alarms) to the fire brigade. A time channel can turn on/off this function.⁹⁷

Trained personnel are required on site to locate the fire (the room) and take the correct measures/actions depending on if there is a fire or not.

Normally analog smoke detectors and zones with smoke detectors only, come in question to be programmed (via WinG3) for alert annunciation. Heat detectors and manual call points should normally not come in question for Alert Annunciation. A manual call point can only activate the **AA** function if there are no other fire alarms activated in the system (i.e. the second fire alarm will turn off the **AA** function)⁹⁸.

The **AA** function is normally turned on (enabled) during daytime working hours only. A time channel can turn on/off (enable / disable) the **AA** function. When the **AA** function is turned on (enabled) it is indicated by the LED **Routing equipment** "Fire brigade tx delay" on the c.i.e. front. Normally only one time channel is used for this function but two or more channels can be used. The **AA** function can, as an alternative, be continuously "on".

NOTE! The **AA** function can be de-activated (turned off) via menu H2/B10 and will then stay so until turned on (normal) again via menu H2/B10.

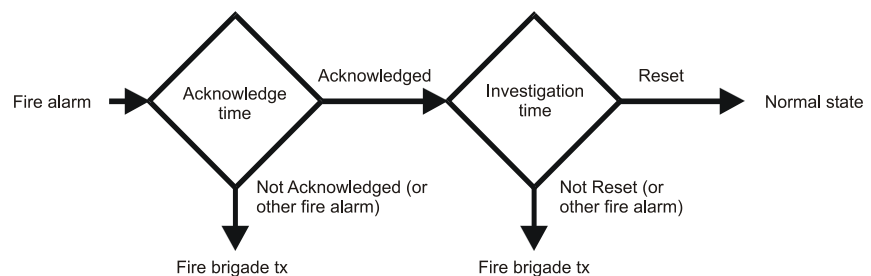

Figure 21. The Alert Annunciation function flow chart.

⁹⁶ A zone with the AVF not selected would in this state activate a fire alarm in EBL512 G3.

⁹⁷ Using an internal time channel is a VdS violation.

⁹⁸ This is valid even if "Multiple alarms within same zone" is selected (via WinG3).

Alert Annunciation function:

Indications, print-outs, actions, etc. for an **AA** alarm are the same as for a normal fire alarm **except the output "Fire alarm" for routing equipment (fire brigade tx) in each c.i.e. that will not be activated directly.**⁹⁹

The **AA** alarm has to be acknowledged within an acknowledge time and the **AA** alarm has to be reset within an investigation time, else the output(s) for routing equipment (fire brigade tx) will be activated.

During the acknowledge and investigation times:

- If a fire alarm is activated by a detector / zone not programmed for Alert Annunciation or if fire alarm is activated by a manual call point, the output(s) for routing equipment (fire brigade tx) will be activated.
- If "Multiple alarms allowed within same zone" is set via WinG3, more than one AA alarm is allowed within that zone.
- "Number of zones" can be set via WinG3. Normally only one zone with **AA** alarm is allowed but up to four zones can be allowed.

Acknowledge and Reset is done on the Alert annunciation unit 1735 / 1736 or Alert annunciation controller 1740. A programmable output ("Alert Annunciation Activated") for indication and programmable inputs ("Alert Annunciation Acknowledge" and "Alert Annunciation Reset") can also be used. **In some conventions can this also be done in the c.i.e. (when a soft key "Ackn. alert annunciation" is available).**

NOTE! The text "Ackn. alert annunciation" above the soft key will only be visible when there is an AA alarm activated, i.e. when there is an AA alarm that can be acknowledged.

The Acknowledge time can be set to 0-120 seconds.

The Investigation time can be set to 0-9 minutes.

NOTE! According to EN54-2, the total delay of fire alarm routing equipment must not exceed 10 minutes (i.e. Acknowledge time + Investigation time \leq 10 min.).

⁹⁹ **NOTE!** Programmable outputs type "Fire brigade tx" will however be activated if not the following is added to the control expression: **AND NOT Alert Annunciation Activated.**

16.14 Alarm Acknowledgement Facility (AAF)

This facility is used on the Australian market only.

The **AAF** function is similar to the "Alert Annunciation function" (see page 104).

One **AAF** zone can consist of one to five analog smoke detectors (4300 / 4301), one **AAF** buzzer (e.g. Sounder base 3379) and one **AAF** Control (**AAFC**)¹⁰⁰. All connected on one **COM** loop.

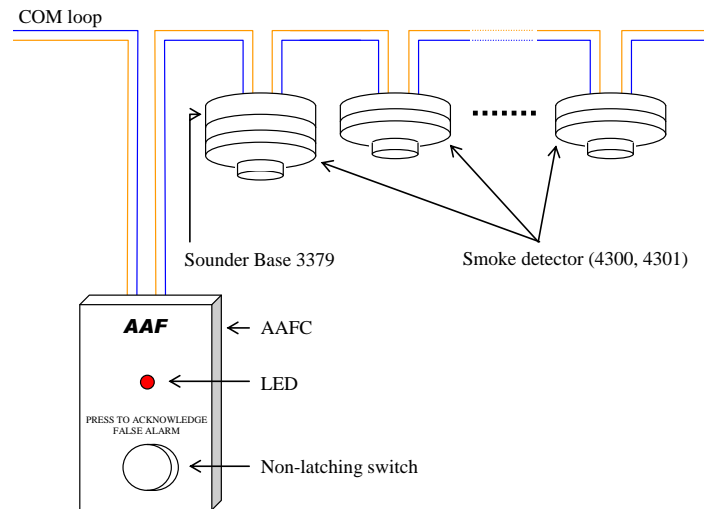

Figure 22. Alarm Acknowledgement Facility units.

AAF function (see also the flow chart in the following figure):

- One of the detectors in an **AAF** zone reaches its fire alarm level.
The **AA** Process starts and the **AAF** buzzer sounds.
- The **Acknowledgement Period** starts
(**A** Period=10-60 sec. -- programmable via WinG3).
- If it is a false alarm, acknowledge the alarm on the **AAFC** before the **A** Period is ended.
- After acknowledgement an **Investigation Period** starts and the **AAF** buzzer is silent
(**I** Period =0-3 min. -- programmable via WinG3).

The **AA** Process ends if all the detectors in the **AAF** zone becomes normal again (goes below its fire alarm level) during the **I** Period.

If the **A** or **I** Periods run out during the **AA** Process and any detector in the **AAF** zone still is over its fire alarm level, normal fire alarm(s) will be activated.

¹⁰⁰ This unit is available on the Australian market only.

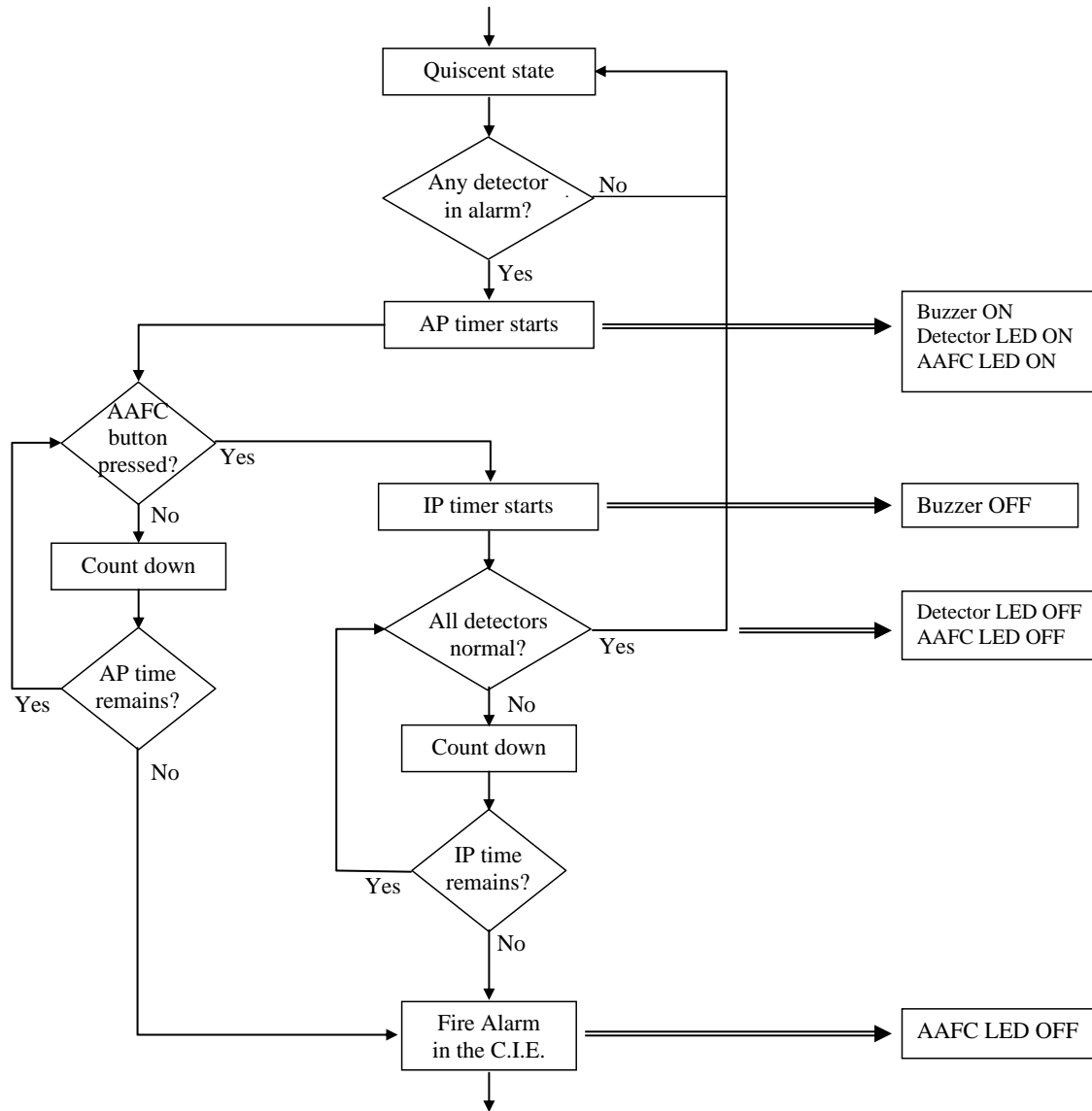

Figure 23. Alarm Acknowledgement Facility (AAF) flow chart.

During the AAF Process, an AAF alarm will be indicated in the c.i.e. display

.... during the Acknowledgement Period (A Period):

AAF zone xx, activated

.... during the Investigation Period (I Period):

AAF zone xx, investigation in progress

The AAF zone xx (xx=00-99) is only valid for the c.i.e. it is shown in, i.e. not for the whole system.

NOTE!

All devices belonging to an AAF zone must be connected to one c.i.e.

The detectors in an AAF zone can be one to five and not be programmed as 2-unit-dependent and not be controlled by the Alert Annunciation function.

Only Analog photo electric smoke detector 4301 and Analog multi detector 4300 can be used for AAF. If the Analog multi detector 4300 is used, it must be programmed as type "Two addresses", so that only the "smoke part" of the detector can be used for AAF.

Max. 100 AAF zones (00-99) per c.i.e.

The AAF buzzer (e.g. Sounder base 3379) has to be programmed with the trigger condition "AAF zone alarm" (and other trigger conditions).

16.15 Quiet alarm

Quiet alarm is normally used in conjunction with the I/O Matrix board 4582¹⁰¹, an application board for fan control¹⁰² and an I/O unit 3361 for fan control.

Smoke detectors, programmed for quiet alarm, can be used e.g. for controlling fans (stop / start depending on the type of fan).

Indications and actions:

- Detector LEDs are turned on (i.e. also a connected ext. LED).
- In the c.i.e. display: **Quiet alarm detector ZZZ-AA** and a user definable alarm text, if programmed.
- LEDs "Fire" in the c.i.e. are blinking (0.4 / 0.4 sec.).
- Buzzer in the c.i.e. sounding (0.8 / 5 sec.).
- Programmable outputs for quiet alarm, e.g. 3361 outputs controlling supply air fans and standard fans i.e. any output with a control expression containing trigger conditions "Quiet Alarm Zone" or "Quiet Alarm Zone Address".

Quiet alarms are non-latching, i.e. they will be automatically reset when the alarm point / zone is no longer above alarm level.

NOTE! Quiet alarm can also be programmed for a 3361 unit "zone line input". In such a case only non-latching detectors can be used.

16.16 Fire alarm type A and Fire alarm type B

Normally the c.i.e. relay output "Fire alarm" is used for Fire alarm routing equipment (Fire brigade tx). This output is activated for fire alarm from any alarm point or zone line input (General fire alarm).

If the fire alarm routing equipment has provision for transmission of several fire alarm signals and the alarm receiver has provision for reception of several fire alarm signals, a fire alarm type B will indicate

¹⁰¹ See "I/O Matrix board 4582", page 32.

¹⁰² The Fan control panel 4593 can be used for control of up to eight fans.

that only one detector is activated, which *could* be a nuisance alarm. If a fire alarm type A is received, the probability of a real fire is higher than for a fire alarm type B. The alarm receiver can take different actions depending on if it is a type A or B fire alarm.

16.16.1 Fire alarm type B

The output shall be programmed (via WinG3) as type "Routing equipment" and have the trigger condition "**One detector alarm**".

The output will be activated for fire alarm from **one** analog addressable smoke, heat or multi¹⁰³ detector only.

16.16.2 Fire alarm type A

The output shall be programmed (via WinG3) as type "Routing equipment" and have the trigger condition "**Multiple detector alarm**".

The output will be activated for fire alarm from:

- **Two or more** analog addressable smoke, heat or multi detectors.
- **Any** manual call point
- **Any** zone line input
- **Any** programmable input with the trigger condition "General Fire"

16.17 Disable alarm points and outputs

Temporary disablements are made via the menu H2 sub menus. For more information see EBL512 G3 Operating Instructions MEW01349, chapter "Disable or re-enable (H2)". The disablements are re-enabled via the menu H2 sub menus.

Regular disablements are made via time channels, see chapter "Time channels", page 137.

When alarm reset method "Single with automatic disablement" is selected via the WinG3 "System Properties", the function will be as follows:

If an alarm point or zone is *in alarm state when being reset* it will not only be reset but also disabled. It has to be re-enabled (via menu H2/B5) the same way as if it was disabled via menu H2/B1-B2.

Disabled alarm points and outputs are indicated by LED **Fault / Disablements** "General disablements" on the c.i.e. front and are listed in menu H4/U1-U2.

Enhanced Disablement (Default) = Fire alarm, pre-warning and fault signal cannot be activated by the disabled alarm point/zone. If only

¹⁰³ **NOTE!** A multi detector can have one presentation number (Zone-Address) or two presentation numbers depending on how it is programmed via WinG3. One presentation number = one detector and two presentation numbers = two detectors regarding fire alarm types A and B.

fire alarm and pre-warning shall be disabled, "Enhanced Disablement" shall not be selected, see chapter "System properties, Page 2", page 136.

NOTE! Enhanced Disablement is NOT valid when a time channel is used for disablements, only when menu H2/B1 or B2 is used.

16.17.1 Disable zone

A whole zone (all addresses within a zone, except the manual call points) can be disabled via menu H2/B1. Re-enabled via menu H2/B4.

16.17.2 Disable zone / address

Individual alarm points can be disabled via menu H2/B2. Re-enabled via menu H2/B5.
Time channels can be used to disable and re-enable automatically.

16.17.3 Disable control output

All outputs (except outputs of type "Alarm Device") can be individually disabled via menu H2/B3. Re-enabled via menu H2/B6. Disabled output will stay in (or return to) the normal condition for the output respectively.

16.17.4 Disable / Re-enable output type

The control outputs can be collective disabled via menu H2/B7, type:
"Control (general)"
"Extinguishing"
"Ventilation"
"Control/exting./vent."
"Interlocking"

It is possible to do this for one or more specific control units or for all control units (i.e. the whole system). Re-enabled via menu H2/B7. Disabled outputs will stay in (or return to) the normal condition for the output respectively.

16.17.5 Disable / Re-enable alarm devices

The control outputs of type "Alarm device (sounder)" can be collective disabled via menu H2/B8. It is only possible to do this for all control units (i.e. the whole system). Re-enabled via menu H2/B8. Disabled outputs will stay in (or return to) the normal condition for the output respectively.

16.18 Disable interlocking output

Individually disabled via menu H9/C4. Re-enabled via menu H9/C5. See also chapter "Disable interlocking output (H9/C4)", page 89.

16.19 Disable outputs for routing equipment

Disabled and Re-enabled via menu H2/B9. For more information see EBL512 G3 Operating Instructions MEW01349.

16.20 Disconnect & Re-connect loop / zone line input

Disconnected via menu H8/S1 and Re-connected via menu H8/S2:

COM loop

Zone line input

Addr. zone interface (3361 zone line input)

For more information see EBL512 G3 Operating Instructions MEW01349.

16.21 External time channels

39 external time channels can be used to:

- disable and re-enable alarm points
- turn the Alert Annunciation function on/off
- activate programmable control outputs
- turn Alternative alarm algorithm for analog detector types 430x on/off
- turn the 2-unit dependence function on/off

The 39 external time channels are for the whole system. One programmable input with trigger condition/type "External Time Channel" is used for each external time channel, which also is given a "Name". The input is controlled by some external equipment, e.g. another time system, a key switch, a timer, etc. with a normally open contact (normally low) or a normally closed contact (normally high). When the input is "activated" the time channel is ON.

NOTE! You must not use more than one input per time channel. (This is checked in the "Validity check" in WinG3).

16.22 Test mode

Up to four zones can be set in Test mode at the same time. Alarm points / zones can be tested during the Monthly test via menu H1 or separately via menu H7. For more information see EBL512 G3 Operating Instructions MEW01349. The LED "Test mode" on the c.i.e. front indicates one or more zones in Test mode. Zones in Test mode are also simultaneously shown in the c.i.e. display. Disablements, faults and fire alarms have higher priority, i.e. the presentation of zones in Test mode will be suppressed during such a condition. In order to shorten the testing time, any time delay before alarm will be "turned off" in Test mode.¹⁰⁴

16.23 Test alarm devices

The programmable outputs of type "Alarm device" can be collectively activated via menu H8/S5, which make it possible to test the alarm

¹⁰⁴ Any 2-zone / -address dependence and the function "delayed alarm" will be ignored.

devices. (The test cannot be started if fire alarm already is activated in the system.). One or all control units can be selected. When the test starts the alarm devices will be "on" for 1 second ($\pm 1s$)¹⁰⁵, "off" for 29 seconds ($\pm 1s$), "on" for 1 second and so on.¹⁰⁶

NOTE! Also disabled (and silenced) alarm devices will be tested.

The test is stopped via menu H8/S5, if a fire alarm is activated in the system or after one hour.

16.24 Test of routing equipment

Via menu H1 it is possible to test the "Fault condition" and "Fire alarm" outputs for routing equipment (Fault tx, Fire brigade tx and corresponding programmable outputs). Open door etc. will not affect the test.

In menu H1, select "Yes" and press " \leftarrow " to start the test. A 060 seconds count-down starts. The "Fault condition" output will be activated¹⁰⁷, indicated by LED "Fault tx activated" on the c.i.e. front. After 30 seconds will also the "Fire alarm" output(s) be activated, indicated by LED "Fire brigade tx" on the c.i.e. front. After additional 30 seconds the test will be ended and the outputs and LEDs will go back to "normal" status.

16.25 Calibration of supervised outputs

The supervised (monitored) outputs have to be calibrated after the installation.¹⁰⁸ This is done via a menu (H5/A1) in the c.i.e.

Calibration range is **4K7 – 50K** or **470 nF – 5 x 470 nF**. If the calibrated value is outside the range respectively or if the actual value differs from the calibrated value \pm a small tolerance, a fault will be generated.

16.26 Service signal

All smoke detectors get contaminated no matter what environment they are mounted in. In some environments it goes faster than in others – depending on type of activity etc.

Conventional smoke detector: The sensitivity will normally increase in most environments. This can result in unwanted false alarms

¹⁰⁵ Some COM loop unit outputs might be "on" a little longer.

¹⁰⁶ The output activation will be continuously (steady). For the alarm devices 3377 and 3379, the tone with the highest priority level (and type "alarm device") will be automatically selected.

¹⁰⁷ **NOTE!** Fault condition outputs are normally activated in "normal" state, i.e. they will in this case be de-activated.

¹⁰⁸ C.i.e. outputs S0-S3: E-o-l resistor 33K. 1 – 5 resistors (33K) can be used. 3364 outputs VO0-VO1: E-o-l capacitor 470 nF. 1 – 5 capacitors (470 nF) can be used.

(nuisance alarms) since all conventional smoke detectors (except 4350, see page 125) have a fixed fire alarm level. Conventional smoke detectors have no service signal output and have to be replaced on a regular basis (i.e. before being too contaminated).

Analog smoke detector: The sensitivity will automatically be constant.¹⁰⁹ **Service signal** will be activated at a fixed **service level**. For detectors 4300 and 4301 (in NORMAL mode), Service signal will be activated when the week average sensor value is ≥ 1.8 %/m.

For more information, see EBL512 G3 Operating Instructions MEW01349 chapter "Sensors activating Service signal (H4/U5)" and "Acknowledge Service signal (H8/S3)".

16.27 **Fault signal (fault condition)**

Fault signal, fault messages, fault acknowledge, etc. are described in EBL512 G3 Operating Instructions MEW01349, chapter "Fault".

Programmable inputs can be used to activate fault signal in the EBL512 G3 c.i.e. See chapter "Programmable inputs", page 63.

16.28 **Alarm texts**

The alarm texts are shown in case of fire alarm.

When a fire alarm is activated, the presentation number (Zone – Address) will be shown in a field in the middle of the c.i.e. display. On the row just below the presentation number, the user definable alarm text for that alarm point will be shown, if programmed.¹¹⁰ The alarm text will also be presented in Ext. Fire Brigade Panels, etc. The alarm text will be printed when a printer is available in the c.i.e or the Ext. FBP.

See also EBL512 G3 Operating Instructions MEW01349, chapter "Fire alarm".

The alarm texts, up to 40 alphanumeric characters, are created and downloaded via WinG3. Each addressable alarm point can have the same alarm text displayed in the Ext. FBPs 1826 & 1828, the Alert Annunciation units 1735 & 1736 and in the Ext. Presentation unit 1728 (or a different alarm text in each unit).

16.28.1 **Creating the alarm texts via WinG3**

In the dialog box for any alarm point (e.g. a detector/sensor)¹¹¹, there is a "Text" field where the alarm text for that alarm point can be typed

¹⁰⁹ The detector is supervised at all times and adapts its fire alarm level in relation to the contamination of the detector, see chapter "Week average sensor value", page 91.

¹¹⁰ See also chapter "Limitations", page 169.

¹¹¹ In WinG3.

(or edited). The alarm text will be shown in the c.i.e. display when this alarm point has activated fire alarm.

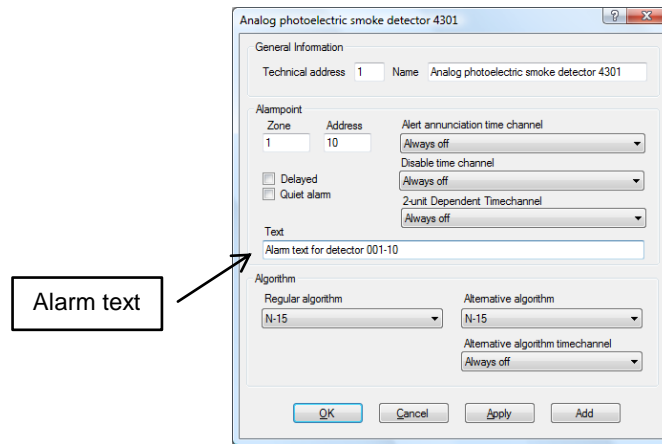

Text editor

The alarm text can, as an alternative, be typed (or edited) in the WinG3 "Text editor" (menu System | Edit Alarm Texts...).

No matter where the text is typed, it will be shown on both places.

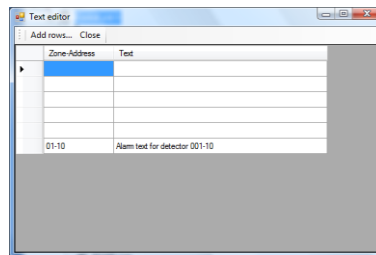

Explanations:

Zone-Address column

Shows the already programmed alarm points (e.g. 001-01, 001-02, 002-01 etc.).

Only the texts have to be typed / edited in the "Text" column.

Shows the already programmed zones, i.e. I/O unit 3361 zone line inputs programmed with address "00" (i.e. ZZZ – 00) and 8 zones expansion board 4580 zone line inputs.

Only the texts have to be typed / edited in the "Text" column.

Text column

Shows already programmed alarm texts. Texts can be typed / edited here.

NOTE! If any alarm point shall have a different alarm text in one or more of the "display units" 1826, 1828, 1735, 1736 or 1728¹¹², the text has to be typed in the WinG3 "Text editor", **for the "display unit" respectively** (Properties | Edit texts...):

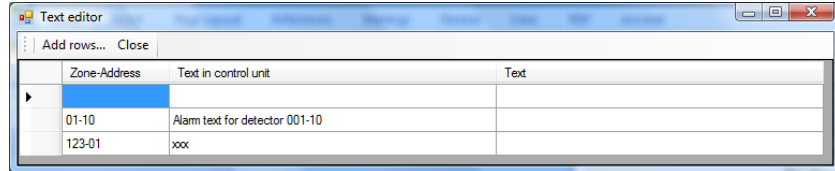

Explanations (Text editor for **one** specific "display unit"):

Zone-Address column

Shows the already programmed alarm points (e.g. 001-01, 001-02, 002-01 etc.).

Shows the already programmed zones, i.e. I/O unit 3361 zone line inputs programmed with address "00" (i.e. as ZZZ – 00) and 8 zones expansion board 4580 zone line inputs.

Text in control unit column

Shows already programmed alarm texts for each alarm point / zone. This is information only and cannot be edited. These texts will be displayed in the c.i.e. and all "display units" 1826, 1828, 1735, 1736 and 1728 if there are no other texts programmed in the "Text column".

Text column

The text to be shown in **this** "display unit" for the alarm point / zone respectively, has to be typed (edited) here. **NOTE!** In this "display unit" this text will now be shown instead of the text in the "Text in control unit" column, for the alarm point / zone respectively.

16.28.2 Downloading alarm texts to the DU:s 1728 / 1735 / 1736 and ext. FBP:s 1826 / 1828

The texts will be downloaded when the site specific data (SSD) is downloaded via WinG3.

The unit respectively has to be set in S/W mode xxxx – **1587**

16.29 Real time clock (RTC)

Each control unit has an RTC. It is used for (date) and time presentation for fire alarms, faults, event logging and the time channels 2-14. In a system with two or more control units in a TLON network is the time in all control units synchronised.¹¹³

¹¹² Regarding text priority order etc. see Technical Description (chapt. "User definable text messages") for the "display unit" respectively.

¹¹³ The calendar and clock can be set in any c.i.e. for the whole system. Every day (at midnight) all calendars and clocks will be synchronised.

16.29.1 Daylight saving time

The time is automatically changed when the Daylight saving time period starts and stops respectively, if set so in WinG3. When, is depending on which convention that is used:

- Australian convention: Forward 1 hour the first Sunday in October, 02:00 → 03:00. Backward 1 hour the first Sunday in April, 03:00 → 02:00.
- New Zealand convention: Forward 1 hour the last Sunday in September, 02:00 → 03:00. Backward 1 hour the first Sunday in April, 03:00 → 02:00.
- All other conventions: Forward 1 hour the last Sunday in March, 02:00 → 03:00. Backward 1 hour the last Sunday in October, 03:00 → 02:00.

16.30 Loss of main power source

Regarding the Main power source and Second power source, see chapter "Power supply", page 161.

16.30.1 Fault: Loss of main power source

The delay time for the fault "Loss of main power source" can be set (in WinG3) to 1 – 300 minutes. (A delay time > 30 minutes is a violation to the EN54-2 standard.

16.30.2 LCD backlight

In order to reduce the current consumption the LCD backlight will never be turned on during loss of the main power source.

16.31 Evacuate

When the soft key "Evacuate" (P7)¹¹⁴ is pressed¹¹⁵, all outputs programmed for sounders (i.e. type "Alarm devices"), will be collective turned ON (steady). This is indicated in the LCD:

Evacuate in progress

The sounders will remain turned ON until they are turned OFF by pressing the soft key "Evacuate off" (P7).¹¹⁶

NOTE 1! The alarm devices (sounders) will always be activated steady (sound continuously) irrespective of the fact that the outputs can be set to anything else for fire alarm (e.g. intermittent).

¹¹⁴ The soft key "Evacuate" is only visible / valid for the Belgian, British Standard, Hungarian, Spanish and Ukrainian conventions.

¹¹⁵ Alt. when a programmable input is activated. One input per c.i.e.

¹¹⁶ Alt. when the programmable input is de-activated.

NOTE 2! The text "Menu" above the soft key (P4) is visible in the display only if the door in the c.i.e. is open, while the text "Evacuate" / "Evacuate off" above (P7) is always visible in the current conventions.

16.32 WinG3 menu Tools

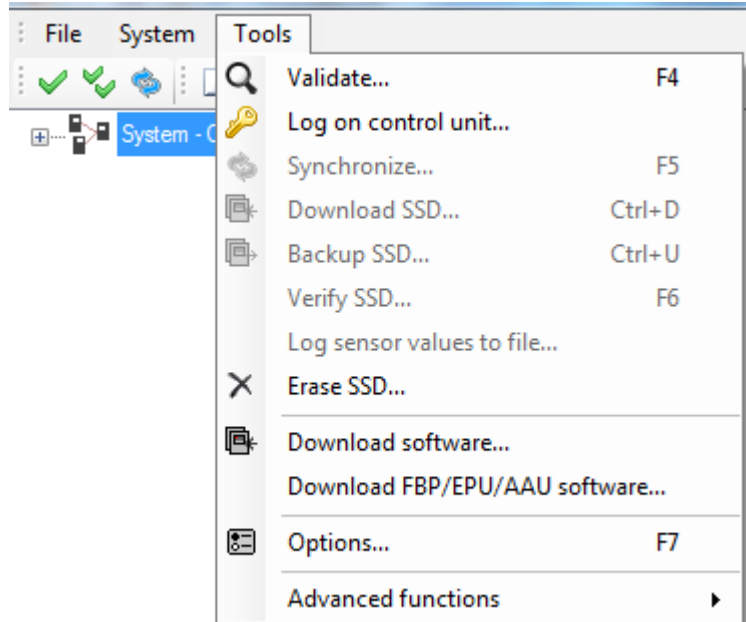

Figure 24. WinG3 menu "Tools". Some commands are disabled if you have not logged on to the control unit.

The WinG3 menu "Tools" is used, when the PC is connected to an EBL512 G3 control unit for e.g. download / backup of SSD.

Validate: The SSD is validated automatically before downloaded to an EBL512 G3 but can also be done via this menu.

Log on control unit: Log on / Log off to an EBL512 G3.

Synchronize: (When connected and logged on to an EBL512 G3.) Data (i.e. faults, disablements, etc.) will be synchronized, i.e. the same **data / information** in all control units and WinG3. **Can also be done via menu H8/S8 in the c.i.e.**

Download SSD: (When connected and logged on to an EBL512 G3.) For downloading of SSD to one or more EBL512 G3 control units and connected Display Units (e.g. ext. FBP).

Backup SSD: (When connected and logged on to an EBL512 G3.) For backup (upload) of SSD from all the EBL512 G3 control units and connected Display Units (e.g. ext. FBP).

Verify SSD: (When connected and logged on to an EBL512 G3.) The SSD stored in an EBL512 G3 control unit is compared with the SSD open in WinG3. If they are the same, the checksums should also be the same.

Log sensor values to file: Sensor values etc. can be logged to a file (.txt) for specified detector(s).

Erase SSD: (With EBL512 G3 in boot mode.) The SSD stored in an EBL512 G3 control unit will be erased. Also the SSW (see Operating Instructions) will be erased.

Download software: (When connected and not logged on to an EBL512 G3.) For download of S/W (.bin file) to one EBL512 G3 control unit. (There is one .bin file for each language / customer.)

Download FBP/EPU/AAU software: (When connected to a Display Unit.) For download of S/W (.bin file) to one Display unit.

Options: WinG3 settings. A Convention (one for each country) is selected the very first time WinG3 is opened. Can be changed if Level 2 is selected, see below. Display Unit language can be selected as well as the WinG3 language.

Advanced functions: Can be one of three alternatives:

No Level selected: Alarm algorithm parameters cannot be changed.

Level 1 selected: All alarm algorithm parameters except the fire alarm parameters can be changed.

Level 2 selected (which require a special password): All alarm algorithm parameters can be changed. The convention for the open installation can be changed.

17 Special New Zealand functions

NOTE! The functions in this chapter are valid for the **New Zealand convention only**.

17.1 Alarm devices

In the New Zealand convention only, the "FIRE" LEDs will indicate steady instead of blinking when the alarm devices are disabled, see below.

17.1.1 Silence alarm devices (inside switch)

On the c.i.e. front, the button "Silence alarm devices" (see Operating Instructions MEW01349, button "P2") is called the "inside switch" and toggles between two states:

- **Alarm devices disabled**
All programmable outputs of type "Alarm devices" are disabled, i.e. they cannot be activated.
- **Alarm devices not disabled**
All programmable outputs of type "Alarm devices" enabled, i.e. they can be activated.

If the inside switch is in its disabled state when you are closing the c.i.e. door the buzzer will beep steady (continuously) and the message "**Silence switch left active**" will be shown in the display. This message has lower priority than fire alarms but higher than other disablements and faults.

NOTE! The inside switch has no function if the outside switch (see below) is activated (on).

17.1.2 New Zealand FB Silence switch (outside switch)

The "**New Zealand FB Silence switch**" is called the "outside switch" since it is placed outside the c.i.e. The outside switch is a key switch and is connected to a programmable input with the trigger condition "Silence alarms".

The outside switch is turned ON (i.e. from not activated to activated state).

- All programmable outputs of type "Alarm devices" are disabled¹¹⁷, i.e. they cannot be activated. The "inside switch" (see above) has no function.
- The c.i.e. built-in buzzer is silenced.
- A fault is generated¹¹⁸: "**FAULT: FB Silence switch active, control unit xx**"

¹¹⁷ Indicated by LED "General disablements" on the c.i.e. front.

¹¹⁸ Always latched, regardless of if faults are programmed to be not latched.

The outside switch is turned OFF (i.e. from activated to not activated state).

- "FAULT: FB Silence switch active" will be Serviced.¹¹⁹
- Any fire alarm ("ALARM") and acknowledged alarm ("ACKNOWLEDGED") will automatically be disabled / isolated. (I.e. it has to be re-enabled via menu H2/ B5.) Indicated by LED "General disablements" on the c.i.e. front.
- Any fire alarm ("ALARM") and acknowledged alarm ("ACKNOWLEDGED") will automatically change the state to "Isolated alarm" (see below) and in the fire alarm list (presented in the display) "ALARM" or "ACKNOWLEDGED" will be replaced with "ISOLATED".

An example:

1234567890123456789012345678901234567890

1. First alarm: 002-03 Alarm number 1 (of 1)

2. ISOLATED alarm

3. Zone Address

4. 002-03 SMOKE

5. User definable alarm text for 002-03.

6.

7.

8.

9.

10. Menu

11.

12.

13.

14.

17.1.2.1

Isolated alarm

A fire alarm will automatically change state to "Isolated alarm" when the "outside switch" (see above) is turned off, i.e. when it is not activated any more (see above).

The following is valid for an isolated alarm.

- LEDs "Fire" (on the c.i.e. front) not activated.
- The c.i.e. built-in buzzer not activated.
- Presented as isolated alarm, see the example above (ISOLATED
- Programmable outputs not activated.

¹¹⁹ Since this fault is always latched, it has to be acknowledged via menu H6.

- Output for routing equipment (Fire brigade tx) not activated.

17.2 Battery faults

For other conventions, see chapter "Security functions", page 162.

17.2.1 FAULT: Battery

The following battery check is performed:

- The battery charging is turned off every 30th second.
- Battery voltage is checked.
- Battery voltage < 18.9 V generates a fault.

Fault message: **FAULT: Battery**

17.2.2 FAULT: Low battery capacity

The following battery check is performed:

- The battery charging is turned off 60 minutes every 24th hour.
- Battery voltage is checked during this 60 minutes period.
- Battery voltage < 24.4 V generates a fault.

Fault message: **FAULT: Low battery capacity**

If a fault is generated it will be **Serviced** after the 60 minutes period.

17.3 Routing equipment isolate (disable)

If any Fire alarm output for routing equipment (Fire brigade tx or Fault tx) is disabled and you are closing the c.i.e. door, the built-in buzzer will beep for two seconds. In the display will be shown: "**Routing equipment left disabled**". This message has lower priority than fire alarms but higher than other disablements and faults.

17.4 Acknowledged alarm

When a fire alarm is activated in the c.i.e. it can be acknowledged by pressing the soft key "Acknowledge alarm" on the c.i.e. front.

An acknowledged alarm has the same functionality as a normal fire alarm except for the indication in the c.i.e. display.

In the fire alarm list (presented in the display) will "**ALARM**" be changed to "**ACKNOWLEDGED**".

An example:

1234567890123456789012345678901234567890

- 1.
- 2.
- 3.
- 4.
- 5.
- 6.
- 7.
- 8.
- 9.
- 10.
- 11.
- 12.
- 13.
- 14.



The screenshot shows a rectangular display area with a light gray background. At the top left, it says "First alarm: 002-03" and at the top right, "Alarm number 1 (of 1)". In the center, the text "ACKNOWLEDGED alarm" is displayed. Below that, the alarm code "002-03" is shown in a large, bold font, followed by the word "SMOKE" in a smaller font. Underneath the code, it says "User definable alarm text.". At the bottom left corner of the display area, there is a small black button labeled "Menu".

Only the alarm currently shown in the display will be acknowledged, i.e. if there are several alarms it is necessary to scroll and acknowledge each alarm separately.

18 Cyber sensor functions

The latest generation of detectors are called "Cyber sensors".

The Cyber sensor "family" consists of the following detectors:

- Conventional photoelectric smoke detector 4352
- Conventional multi detector 4350
- Analog photoelectric smoke detector 4301
- Analog multi detector 4300

NOTE! NOTE! NOTE! NOTE! NOTE! NOTE! NOTE! NOTE!

The analog detectors **4301** and **4300** can via the address setting tool 3314 be set in different modes but in **EBL512 G3** can only **NORMAL mode** be used. See chapters "COM loop units", page 38 and "Functions / Services / Features", page 91, i.e. the analog detectors **4301** and **4300** do **not** use the cyber sensor functions described below.

The conventional detectors **4352** and **4350** uses some of the cyber sensor functions. See the function respectively below.

The **AI function** is used to secure the real fire alarms but also to reduce the false (nuisance) alarms with up to 46 %. The AI function is depending on if the detector is a photoelectric smoke detector (4352 / 4301) or a multi detector (4350 / 4300):

Combined heat and smoke sensing will guarantee reliable and accurate fire alarm detection, e.g. by shortening the delay time and/or raise the sensitivity (i.e. lower the alarm threshold level).

Fire alarm activation in conjunction with temperature rise.

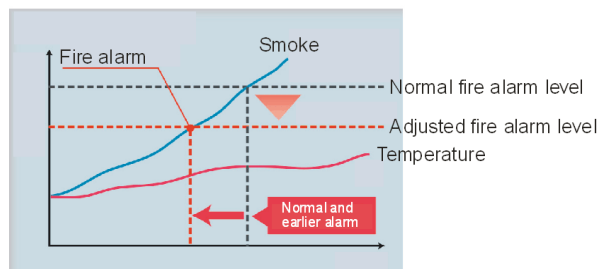

By combined smoke and heat sensing a lower fire alarm level can be used.

Variable delay time. The delay time is influenced by the temporary temperature and/or smoke obscuration changes just before and after the alarm threshold level was passed. The delay time before a fire alarm is activated can be shortened up to 50 % (e.g. from 20 to 10 sec.), or the delay time can be extended in order to reduce false (nuisance) alarms.

Learning function / conditions. The detector will adapt a learning condition depending on the long-time influence of smoke and/or the temperature where the detector is located.

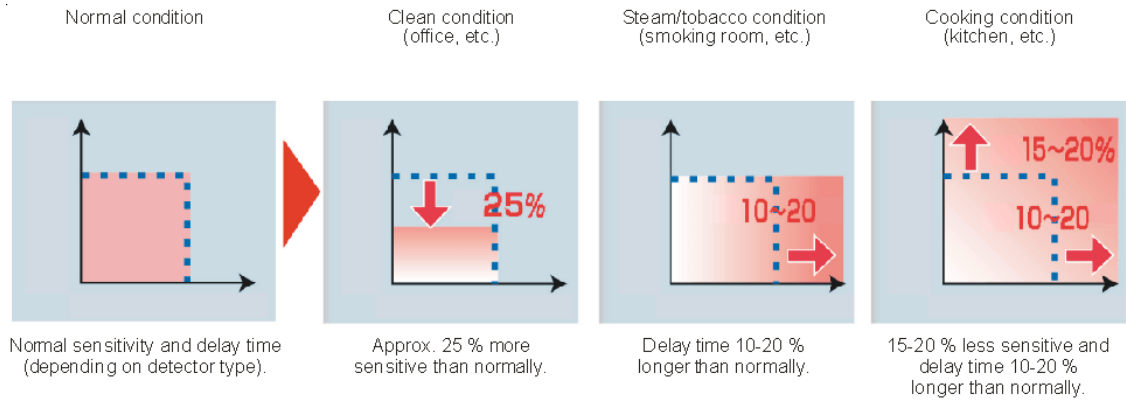

18.1 Pulse up – down counter

The detector have a "pulse up – down counter", starting at "0" and cannot be negative.

18.1.1 Pulse up – down counter for smoke

When the smoke obscuration S (%/m) \geq the alarm threshold level, "1" is added to the counter every second.

When $S <$ the alarm threshold level, "2" is subtracted from the counter every second.

18.1.2 Pulse up – down counter for temperature

When the temperature T ($^{\circ}\text{C}$) \geq the alarm threshold level, "3" is added to the counter every second)

When the temperature rise ΔT ($^{\circ}\text{C}/168\text{sec.}$) \geq the alarm threshold level, "3" is added to the counter every second.

When T or $\Delta T <$ the alarm threshold level, "2" is subtracted from the counter every second.

18.1.3 Pulse up – down counter for smoke & temperature

When $2S + \Delta T \geq$ the alarm threshold level, "1" is added to the counter every second.

When $2S + \Delta T <$ the alarm threshold level, "2" is subtracted from the counter every second.

18.2 Fire judgement

The fire judgement is depending on different functions for the different detector types and if the cause of alarm is smoke S , temperature T or ΔT or a combination of smoke and temperature $2S + \Delta T$.

When the counter shows "9" (i.e. at the earliest after nine seconds in case of S or $2S + \Delta T$ and after three seconds in case of T or ΔT) the following will happen:

4352: Fire alarm is activated.

4350: Depending on the AI function (learning condition, temperature condition, etc.) a delay time has to run out before fire alarm is

activated.

4301: Fire judgement is depending on other alarm and filtering algorithms (see chapter "Functions / Services / Features", page 91).

4300: Fire judgement is depending on other alarm and filtering algorithms (see chapter "Functions / Services / Features", page 91).

18.3 Alarm threshold levels

Depending on the detector type, mode and learning condition there are alarm threshold levels (**S**, **T**, **deltaT** and **2S+deltaT**) for pre-warning, fire alarm and heavy smoke / heat alarm.

The following fire alarm threshold levels are valid for the different type of detectors:

4352:

Learning condition	S[%/m]
	Fire alarm
Normal	4

4350:

Learning condition	S[%/m]	T[deg.]	deltaT [deg./168sec]	2S+deltaT #2
	Fire alarm	Fire alarm	Fire alarm	Fire alarm
Normal	5	57	18	12
Steam/tobacco	5	57	18	12
Clean	3.7	57	18	10
Heating	5	57	no use	12
Cooking	5	57	18	14

#2 **NOTE!** $S \geq 2.5$ (%/m) and $\text{deltaT} \geq 3$ (°C/168 seconds).

4301: Fire alarm threshold level is depending on other alarm and filtering algorithms (see chapter "Functions / Services / Features", page 91).

4300: Fire alarm threshold level is depending on other alarm and filtering algorithms (see chapter "Functions / Services / Features", page 91).

18.4 Learning function / Learning conditions

Depending on the local temperature changes and the local occurrence of smoke where the detector is situated, each detector can after a **learning period**, adapt a more appropriate alarm algorithm than the normal one, a **learning condition**. See also page 123.

18.4.1 Learning conditions

Each detector starts in the Normal condition. There are four **learning conditions** that can be adapted:

- Steam / tobacco condition, depending on the occurrence of smoke, i.e. **level 1** = S [%/m] \geq half the fire alarm threshold level (S).
- Heating condition, depending on rise of temperature, i.e. **level 2** = deltaT [°C/168 sec.] \geq 12 (approx. 4.3°C/min.).

- Cooking condition, depending on the occurrence of smoke together with rise of temperature, i.e. $\text{level } 3 = 2S + \Delta T \geq 10$. **NOTE!** S has to be ≥ 2.5 and ΔT has to be ≥ 3 .
- Clean condition, the most sensitive condition requiring very clean and stable environment, i.e. the values for all the other conditions (level 1, 2 and 3) must not be exceeded.

18.4.1.1 Steam / tobacco condition, level 1

36h	36h	36h	36h	36h	36h	36h	36h	36h	36h	36h	36h	36h	36h	36h	36h	36h	36h	36h	36h
		✓	✓						✓										
1	2	3	4	5	6	7	8	9	10	11	12	13	14	15	16	17	18	19	20

In a **learning period** there are twenty **36h-periods** (i.e. $20 \times 36h = 720h = 30 \text{ days} = \text{one month}$).

During each **36h-period** it is recorded if **level 1** is exceeded at least one time. If so, the **36h-period** will get a check-mark (see example).

If three or more of the 36h-periods during the **learning period** have a check-mark, the Steam / tobacco condition will be adapted. In the example this happens in the **36h-period** no. 10 (i.e. after $10 \times 36h = 360h$).

After the **36h period** no. 20, the next **learning period** starts again in the **36h period** no. 1. The check-marks are inherited from the previous **learning period**. Depending on if **level 1** is exceeded during the **36h period** respectively or not, there will be a check-mark or no check-mark.

36h	36h	36h	36h	36h	36h	36h	36h	36h	36h	36h	36h	36h	36h	36h	36h	36h	36h	36h	36h
			✓						✓										
1	2	3	4	5	6	7	8	9	10	11	12	13	14	15	16	17	18	19	20

In the example, the Steam / tobacco condition will be ended after the **36h period** no. 3, since there are left only two **36h periods** with check-marks in the **learning period** now. (If later, one or more **36h periods** will get a check-mark, the Steam / tobacco condition will be adapted again as long as three or more of the **36h-periods** during the learning period have a check-mark.)

18.4.1.2 Heating condition, level 2

The learning function is the same as for the Steam / tobacco condition, **level 1**.

18.4.1.3 Cooking mode, level 3

The learning function is the same as for the Steam / tobacco condition, **level 1**.

18.4.1.4 Clean condition, level 1, 2 & 3

For this learning condition to be adapted there must be no check-mark for **level 1**, **level 2** and **level 3** respectively during the **learning period**, i.e. no check-mark what so ever.

The **Clean condition** will be ended directly if any **36h period** for **level 1**, **level 2** and **level 3** respectively gets a check-mark, i.e. any check-mark what so ever.

18.4.1.5 Learning condition summary

A detector can adapt the following **learning conditions**, depending on if and when **level 1**, **level 2** and **level 3** are exceeded or not:

Normal condition (default)

or

Clean condition

or

Steam / tobacco condition and/or **Heating condition** and/or **Cooking condition**

The following is valid for the different type of detectors:

4352: This detector uses not the Learning function.

4350: This detector uses the Learning function (for different alarm threshold levels and alarm delay times, depending on smoke & temp.).

4301: This detector uses not the Learning function.

4300: This detector uses not the Learning function.

18.5 Alarm delay time

Depending on the detector type, mode and learning condition the delay times before fire alarm threshold level was exceeded, are for the different type of detectors:

4352: Normally 9 seconds.

4350:

The cause of alarm Learning condition	Delay time[sec]				
	data1[%/m]	S	T	deltaT	2S+deltaT
Normal	< 0.6	39	15	15	data2'/2 #3
	0.6 <=, < 0.8	30			
	0.8 <=, < 2.5	18			
	2.5 <=	9			
Steam/tobacco	< 0.6	39+data2'/2 #3	15	15	data2'/2 #3
	0.6 <=, < 0.8	30+data2'/2 #3			
	0.8 <=, < 2.5	18+data2'/2 #3			
	2.5 <=	9+data2'/2 #3			
Clean	< 0.3	39	15	15	data2'/2 #3
	0.3 <=, < 0.4	30			
	0.4 <=, < 1.3	18			
	1.3 <=	9			
Heating	< 0.6	39	15	no use	data2'/2 #3
	0.6 <=, < 0.8	30			
	0.8 <=, < 2.5	18			
	2.5 <=	9			
Cooking	< 0.6	39	15	15	data2' #3
	0.6 <=, < 0.8	30			
	0.8 <=, < 2.5	18			
	2.5 <=	9			

#3 NOTE! Max. alarm delay time is 60 seconds.

data1 = The average smoke obscuration value (S) for 60 seconds before the alarm threshold level was passed.

data2 = The sum of the difference between the smoke obscuration value (S) and the alarm threshold level every second for nine seconds after the counter shows "9".

data2' = The sum of the difference between the $2S + \Delta T$ value and alarm threshold level every second for nine seconds after the counter shows "9". **4301:** Alarm delay time is depending on other alarm and filtering algorithms (see chapter "Functions / Services / Features", page 91).

4300: Alarm delay time is depending on other alarm and filtering algorithms (see chapter "Functions / Services / Features", page 91).

18.6 Analog data output

The smoke obscuration value (%/m) and the temperature (°C) can be shown via the c.i.e. A new value is calculated every second. (The smoke obscuration value is an average value for the last four seconds.)

The following is valid for the different type of detectors:

4352: This detector has no analog output.

4350: This detector has no analog output.

4301: This detector has a smoke obscuration value output in the NORMAL mode.

4300: This detector has a smoke obscuration value output and a temperature value output in the NORMAL mode.

18.7 Sensitivity compensation

In order to maintain a constant sensitivity regardless of the contamination of the detector, a Contamination Compensation Factor (CCF) is calculated during a 36 hours period as follows:

During 13 minutes, all smoke obscuration values are saved and an average value is calculated. The CCF will be changed if it is lower than the actual CCF, else no change.

After 18 hours, the CCF will be changed if it is lower or higher than the actual CCF. (It will normally be higher by contamination.)

After 18 hours more (totally 36 hours) the CCF will be changed if it is lower or higher than the actual CCF and it will be saved in the detector's EEPROM, so it can be used e.g. after the detector has been without power supply. A new 36 hours period starts.

Max. compensation is 2 %/m. A service signal will then be activated and shown in the c.i.e.

The following is valid for the different type of detectors:

4352: This detector has no sensitivity compensation.

4350: This detector has sensitivity compensation (but no service signal output).

4301: Sensitivity compensation is depending on other alarm and filtering algorithms (see chapter "Functions / Services / Features", page 91).

4300: Sensitivity compensation is depending on other alarm and

filtering algorithms (see chapter "Functions / Services / Features", page 91).

18.8 Self diagnosis of internal devices

The detectors perform an internal check of some vital functions and components (e.g. the IR-LED). In some modes a separate fault message will be shown in the c.i.e.

The following is valid for the different type of detectors:

4352: This detector has no self diagnosis of internal devices.

4350: This detector has self diagnosis of internal devices (but no separate fault output).

4301: This detector has self diagnosis of internal devices.

4300: This detector has self diagnosis of internal devices.

18.9 Address setting check

The indication LED in the detectors **4301** and **4300** will in all modes blink every second when the detector is powered and the COM loop address is not set with the Address setting tool 3314, i.e. as long as the address is "000". The address should be set in the interval 001-255.

19 Control unit properties

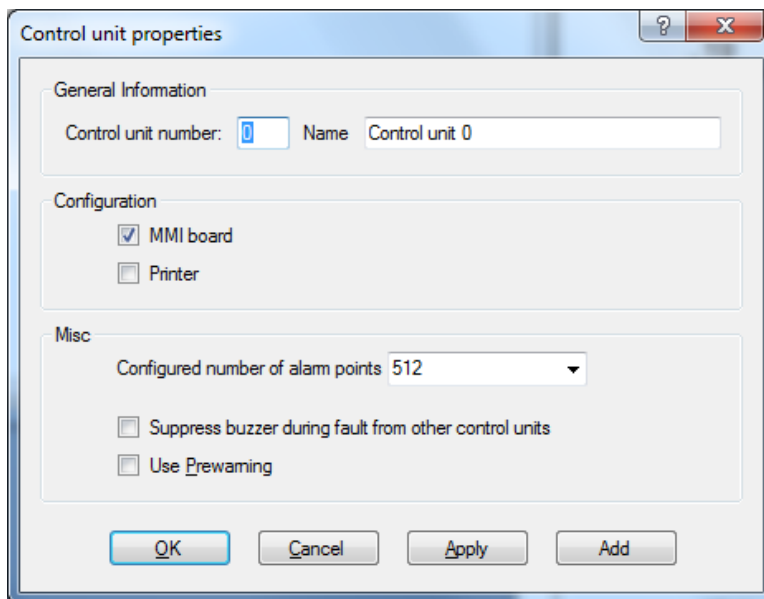

Figure 25. The WinG3 "Control unit properties" dialog box.

NOTE! Default settings in WinG3 might vary depending on convention.

19.1 Control unit properties dialog box

Opens when you add a control unit or via the "Control unit" pop-up menu (Properties...)

19.1.1 General Information

Control unit number: A stand-alone control unit has to have no. 0. In a system (TLON Network) the control units are numbered from 0 to 29.

Name: Normally not changed but can be changed when required.

19.1.2 Peripherals

- MMI board** (default): This check box shall be marked when the c.i.e. has a front with display (i.e. EBL512 G3 type 5000). This check box shall not be marked when the c.i.e. has no front (i.e. EBL512 G3 type 5001).
- Printer** (only valid for EBL512 G3 type 5000) This check box shall be marked when the c.i.e. is equipped with a printer.

19.1.3 Misc.

Configured number of alarm points: 128, 256 or 512.

NOTE! 1020 COM loop unit addresses are always available but max. 512 of these 1020 addresses can be alarm points.

In the **Australian convention only**, the number of alarm points per c.i.e. can be set to 128, 256, 512 or **1020**.

Set the wanted number and the validation check in WinG3 can give a "too many alarm points" warning. The validation check is automatically performed when starting a download of SSD to the c.i.e.

- ❑ **Suppress buzzer during fault from other control units:** This check box shall be marked if faults generated in other control units shall be suppressed in this control unit, i.e. if the buzzer shall sound for faults generated in this control unit only.
- ❑ **Use Pre-warning:** This check box shall be marked if the pre-warning detection shall be enabled, i.e. pre-warnings will be activated in this control unit and presented in all control units. All programmable outputs in the system, with trigger condition "Pre-warning", will be activated (if not disabled).
Checkbox not marked = Pre-warnings will not be activated in this control unit.

19.2 WinG3 Control unit pop-up menu

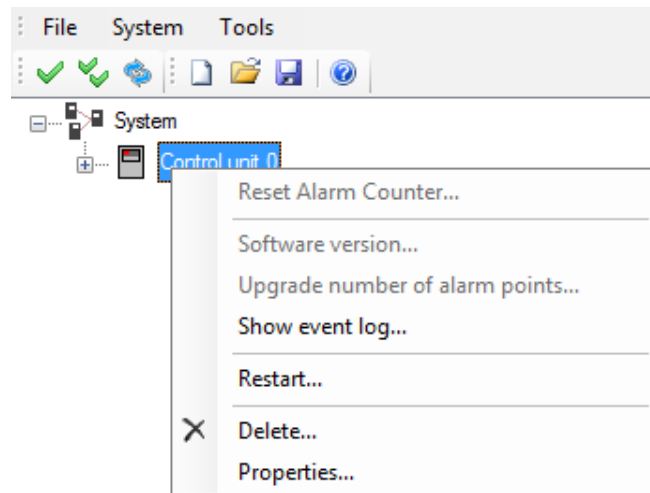

Some commands are disabled since you have to connect and log on to the control unit to be able to select / use them.

19.2.1 Reset alarm counter

The control unit has an alarm counter that can be reset if required. (Level 2, i.e. a special access code is required.)

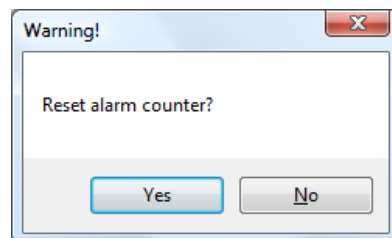

19.2.2 Software version

The control unit software (S/W) version will be displayed.

19.2.3 Upgrade number of alarm points

The control unit is by delivery be configured for 128, 256 or 512 alarm points. Any number of **alarm points** can via **WinG3** be changed on site, normally 128 → 256 → 512.

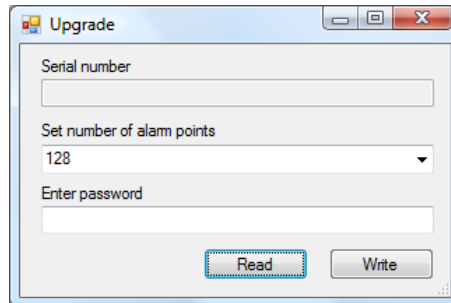

Click "Read" for the current number of alarm points and the serial number for the control unit you are connected to.

If the number of alarm points shall be changed, report the serial number to the producer, in order to receive a password.¹²⁰

Click "Write" to configure the control unit for the new number of alarm points.

19.2.4 Show event log

Three different event log lists (Alarm, Interlocking and General log) can be shown. They are valid for the system.

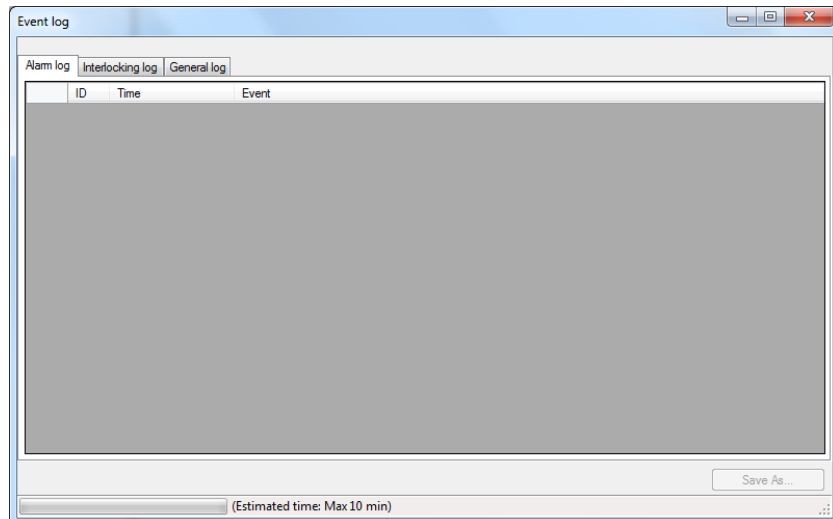

19.2.5 Restart

You can restart control unit via this menu command.

¹²⁰ The password will be generated with a special PC program (with a hardware lock) and is unique for every serial number and number of alarm points combination.

19.2.6

Delete

The selected control unit can be deleted.

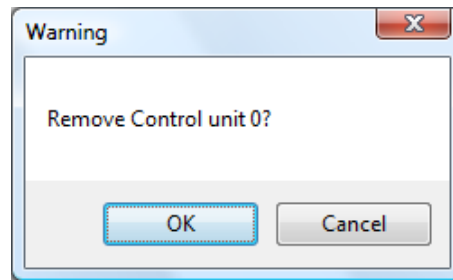

19.2.7

Properties

See beginning of this chapter – Control unit properties dialog box.

20 System properties (settings)

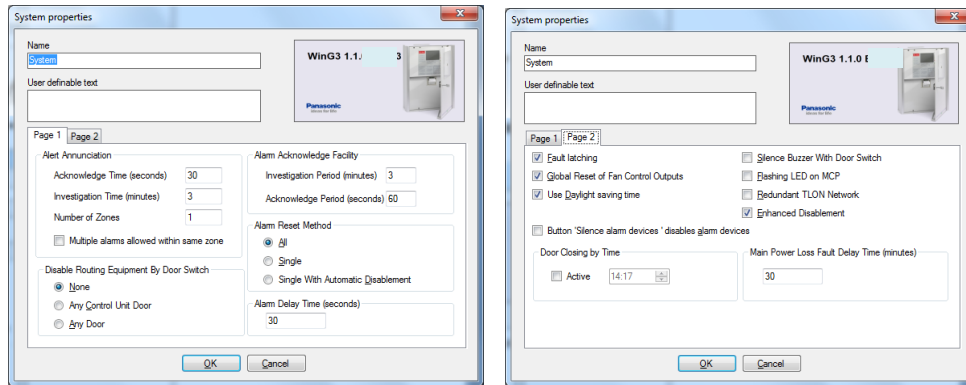

Figure 26. The WinG3 "System properties" dialog box, Page 1 and Page 2.

NOTE! Default settings in WinG3 might vary depending on convention.

20.1 System properties dialog box

Opens via the "System" pop-up menu or via menu "System" (Properties...).

20.1.1 Name

Normally the installation name. (Max. 22 characters.)

20.1.2 User definable text

For user definable text. Two rows á 40 characters are available. The text will be shown in all control units. For more information see EBL512 G3 Operating Instructions MEW01349.

20.1.3 System properties, Page 1

20.1.3.1 Alert Annunciation

See also chapter "Alert Annunciation", page 104.

Acknowledgement time: 30 sec.

30 is default. 0-120 (= 2 min.) is possible.

Investigation time: 3 min.

3 is default. 0-9 is possible.

NOTE! According to EN54-2, the total delay of fire alarm routing equipment (Acknowledge time + Investigation time) must not exceed 10 minutes.

Number of zones: 1

1 is default. 1-4 is possible.

Multiple alarms allowed within same zone

Normally only one Alert Annunciation alarm is allowed within the zone. If more Alert Annunciation alarms within the zone are allowed, this checkbox shall be marked.

20.1.3.2 Alarm Acknowledgement Facility

Used in conjunction with the AAF Control that is available on the Australian market only.

See also chapter "Alarm Acknowledgement Facility (AAF)", page 106.

Investigation period (IP) time: 3 min.

3 is default. 1-3 is possible.

Acknowledge period (AP) time: 60 sec.

60 is default. 10-60 is possible.

20.1.3.3 Disable routing equipment by door switch

Valid for the following control unit outputs for routing equipment:

Fire alarm (for Fire brigade tx)

Fault condition (for Fault tx)

- None** (default): Door open in a C.U. or an ext. FBP will **not** disable these outputs.
- Any control unit door**: Door open in any C.U. will disable these outputs in all C.U:s.
- Any door**: Door open in any C.U. or any ext. FBP will disable these outputs in all C.U:s.

In the display (or via menu H4/U1) is shown (xx = C.U. number):
Fire alarm routing disabled (by open door in CU xx)

20.1.3.4 Alarm reset method

One of the following alternatives shall be selected.

- All** (default): All fire alarms in the system will be reset simultaneously by pressing the "Reset" button (on the c.i.e. front) once.
- Single**: One fire alarm in the system, i.e. the fire alarm shown in the field in the middle of the control unit display will be reset by pressing the "Reset" button once. Any other fire alarm has to be reset the same way, one by one.
This function is a violation to the EN54-2 standard.
- Single With Automatic Disablement**: Like "Single" reset but with the Disablement function (see below) as well.
This function is a violation to the EN54-2 standard.

Disablement function: If an alarm point or zone is reset while it still is in alarm state (e.g. smoke in a smoke detector or a manual call point with a broken glass) this unit will be automatically disabled in order to not activate a new fire alarm within 20 seconds. It will stay disabled until re-enabled via menu H2/B5.

LED Fault / Disablements "General disablements" on the c.i.e. front is indicating one or more disablement in the system.

20.1.3.5 Alarm delay time (seconds)

Valid for the detectors and zone line inputs with this option selected via WinG3¹²¹.

0 is default. 0-255 seconds is possible. Note, this delay time starts when the fire alarm normally should have been activated.

20.1.4 System properties, Page 2

- Latch Faults** (default): All faults have to be acknowledged, also corrected faults.
Checkbox not marked = No fault latching = Not corrected faults have to be acknowledged but corrected faults will automatically be deleted from the fault list.
- Global reset of Fan Controls Outputs**: Reset of fan control system is **global**, i.e. all fan control systems in the EBL512 G3 system will be reset. (Regarding Fan control, see page 32.)
Checkbox not marked = Reset of fan control systems is **local**, i.e. all fan control systems in the c.i.e. where the switch is located will be reset.
- Use Daylight Saving**:
Australian convention: Forward 1 hour the first Sunday in October, 02:00 → 03:00. Backward 1 hour the first Sunday in April, 03:00 → 02:00.
New Zealand convention: Forward 1 hour the last Sunday in September, 02:00 → 03:00. Backward 1 hour the first Sunday in April, 03:00 → 02:00.
All other conventions: According to the current EU regulations, i.e. forward 1 hour the last Sunday in March, 02:00 → 03:00. Backward 1 hour the last Sunday in October, 03:00 → 02:00.
Checkbox not marked = Daylight saving time is not used.
- Button "Silence alarm devices" disables alarm devices**: Function, see page 119. Can be used in all conventions.
- Silence Buzzer With Door Switch**: If the buzzer in the c.i.e. shall be silenced when the door is opened, this checkbox shall be marked. This is a violation to the EN54-2 standard.
- Flash LED on MCP**: The manual call point (type 3333 / 3339) built-in LED will flash to indicate communication with the c.i.e.
Checkbox not marked = This option is disabled, i.e. the LED is switched off until the call point is operated.
- Redundant TLON Network**: This checkbox shall be marked when two TLON Networks shall be used, i.e. each control unit in the system is equipped with two TLON connection boards (1590 / 5090). See also chapter "TLON connection board 1590", page 36.

¹²¹ Regarding the Australian and New Zealand conventions the "Alarm Verification Facility" is valid, see page 103.

- Enhanced disablements:** Disabled alarm point¹²² will not activate pre-warning, fire alarm or fault.
Checkbox not marked = Disabled alarm point¹²² will not activate pre-warning or fire alarm. Fault can still be activated.
This is a violation to the EN54-2 standard.

20.1.4.1 Door closing by time

- Active:** If all fire doors (trigger condition "Fire Door Closing") shall be closed at a definite time every day, this checkbox shall be marked and the time (*hh:mm*) set, e.g. 23:00.

20.1.4.2 Main power loss fault delay time (minutes)

A fault will be activated *mm* minutes after loss of mains (230 V AC). 0 is default. 0-300 minutes is possible.

20.2 Menu System

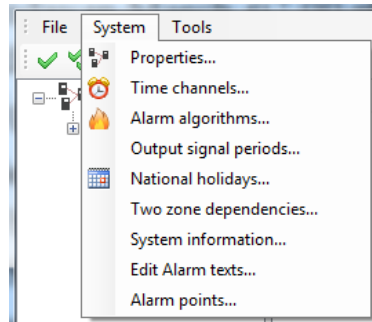

20.2.1 Properties

The same dialog box opens as in Figure 26, page 134.

20.2.2 Time channels

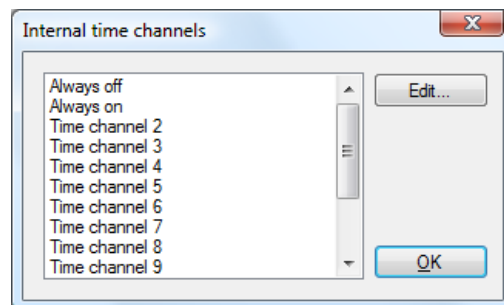

Always off and Always on cannot be edited.

The control unit RTC (real time clock) controls the time channels 2-14. **Five intervals** (interval = one time on & one time off) can be set for each day in time channel 2-14.

Time channels can:

- disable and re-enable alarm points / zones
- set Alert Annunciation on / off

¹²² The sensor values for a disabled analog smoke detector will not be saved.

- disable, re-enable and activate programmable control outputs
- set alternative alarm algorithm for analog detector types 430x on / off
- set 2-unit dependence function on / off

The properties for each **Time channel** (2-14) and each **Day of the week** (Monday – Sunday + National Holiday) have to be set for the channels that shall be used.

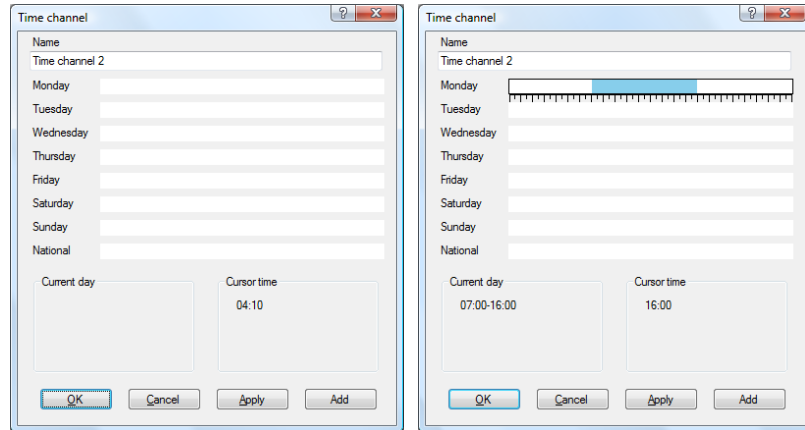
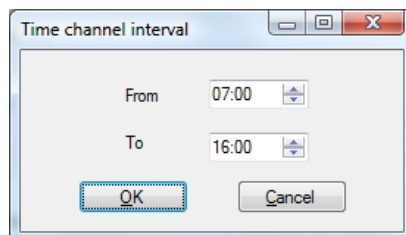

Figure 27. Left: The "Time channel 2" dialog box without any programming done. Right: One time interval is programmed for the Monday (time channel 2 is "on" 07:00 – 16:00).

Name: "Time channel n" is default. Normally not changed but an informative text can be added (e.g. office hours).

Monday: Place the cursor (the "arrow") in the white day field (e.g. Monday). In the "Cursor Time" area (down to the right) is the actual cursor time displayed. Move the cursor in the day field. In the "Cursor Time" area will the corresponding time be displayed. In the correct time position (e.g. 07:00) click the left mouse button and drag the cursor to the right (or left) to the next time position (e.g. 16:00) and drop the cursor. There will now be a box in the day field indicating the time interval when the time channel is "on". The time interval (e.g. 07:00 – 16:00) is also displayed in the "Current Day" area (down to the left).

For each day, five time intervals can be programmed. A time interval can be edited by dragging the whole interval (or the left / right side of it) to the left or right in the day field. Alternatively, double click the time interval box in the day field to open a dialog box for easier time editing:



A time interval can be copied in one day field and pasted into another day field.

Tuesday: Programmed the same way as the Monday.

Wednesday: Programmed the same way as the Monday.

Thursday: Programmed the same way as the Monday.

Friday: Programmed the same way as the Monday.

Saturday: Programmed the same way as the Monday.

Sunday: Programmed the same way as the Monday.

National: Programmed the same way as the Monday. See also chapter "National holidays", page 142.

Current day: The programmed time intervals (when the time channel is "on") for the selected day, are shown here.

Cursor time: The cursor position (time) in the day field respectively, is shown here.

Time channels 3 - 14 are programmed the same way as time channel 2.

20.2.3

Alarm algorithms

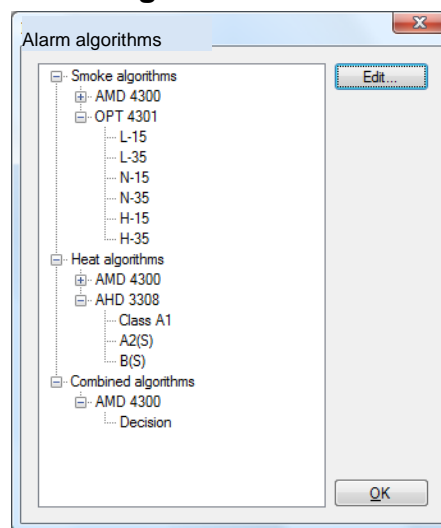

All the different algorithms for the different detector types are shown in the tree view to the left. Click "+" to expand and "-" collapse the tree view.

Select one algorithm and click "Edit" and a dialog box displays depending on the selected algorithm:

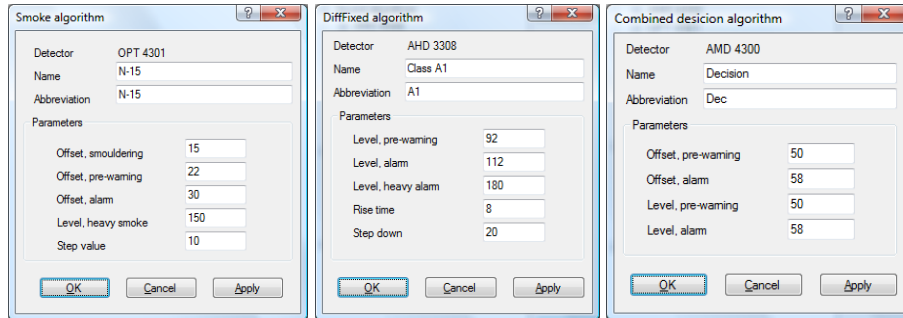

Figure 28. Smoke algorithm **N-15** for 4301, Heat algorithm **Class A1** for 3308 and Combined **Decision** algorithm **Dec** for 4300 respectively.

Detector: Shortening and Type number (e.g. **OPT 4301** = Analog photoelectric (**optical**) smoke detector, **AHD 3308** = Analog heat detector and **AMD 4300** = Analog **M**ulti **D**etector).

Name: Name of the algorithm (e.g. N-15, Class A1 & Decision). Normally not changed.

Abbreviation: The algorithm abbreviation (\leq six characters) as shown in the EBL512 G3 display, menu H4/U4 (e.g. N-15, A1 & Des). Normally not changed.

20.2.3.1

Parameters for smoke algorithms

Offset is a fixed value added to the week average sensor value to get the "alarm" level respectively, e.g. week average sensor value 1 + offset 30 = 31 = the fire alarm level (equivalent to 3.1 % *obscuration per meter*).¹²³

The step value gives the alarm delay time to the algorithm respectively, see chapter "Functions / Services / Features", page 91.

The following example is for the *N-15 algorithm* for the 4301 detector. The values for other algorithms and the 4300 detector are different.

Offset, smouldering: Offset value, default 15 (1.5%/m).

Offset, pre-warning: Offset value, default 22 (2.2%/m).

Offset, alarm: Offset value, default 30 (3.0%/m).

Level, heavy smoke: Heavy smoke level, default 150 (15%/m).

Step value: Default 10.

NOTE! *Changing these parameters will affect the sensitivity and detection time and should be done by authorised personnel only!!!!*

¹²³ The week average value starts at "1" for a new (clean) detector. The very first average value will be calculated within two minutes (after SSD download & restart) and thereafter every week. The fire alarm level will be adjusted or not adjusted every week, depending on if the latest calculated week average value is the same as the previous, i.e. if it has increased or if it has decreased. The week average value will normally increase very slowly in a long-time period, due to contamination.

In addition, a special password is required to change the parameters for fire alarm.

20.2.3.2

Parameters for heat algorithms

The "alarm" levels are fixed, i.e. there are no offset values. The sensor values can be 0-200, which is equivalent to 0-100° C. The rise time and step down gives a rate-of-rise function (used in the A1 algorithm only). See also chapter "Algorithms for analog heat detectors", page 98.

The following example is for the *A1 algorithm* for the 3308 detector. The values for other algorithms and the 4300 detector are different.

Level, pre-warning: Level, default 92 (46° C).

Level, alarm: Level, default 112 (56° C).

Level, heavy alarm: Level, default 180 (90° C).

Rise time: Default 8.

Step down: Default 20.

NOTE! *Changing these parameters will affect the sensitivity and detection time and should be done by authorised personnel only!!!! In addition, a special password is required to change the fire alarm parameters.*

20.2.3.3

Parameters for combined decision algorithm

Offset, see "Parameters for smoke algorithms" above. Level, see "Parameters for heat algorithms" above. See also "4300", page 42.

The following example is for the *Dec algorithm* for the 4300 detector.

Offset, pre-warning: Offset value, default 50 (5.0%/m).

Offset, alarm: Offset value, default 58 (5.8%/m).

Level, pre-warning: Level, default 50° C

Level, alarm: Level, default 58° C.

NOTE! *Changing these parameters will affect the sensitivity and detection time and should be done by authorised personnel only!!!! In addition, a special password is required to change the fire alarm parameters.*

20.2.4

Output Signal Periods

See also chapter "Output signal period", page 74.

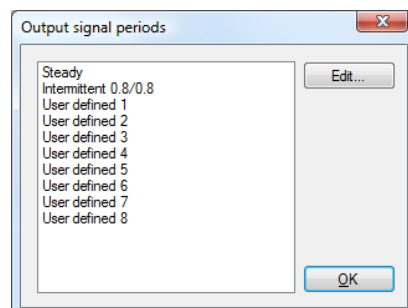

In the list (to the left), **Steady** (continuously) and **Intermittent 0.8 / 0.8 s** are already defined since these alternatives are often used. It is however, possible to define them to something else.

User defined 1-8 have to be defined individually:

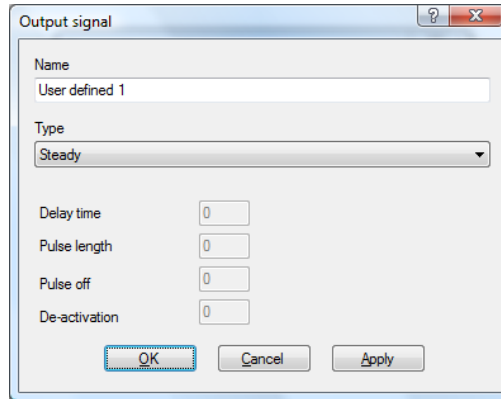

Name: Normally changed to something that describes the output signal (e.g. "Steady") or what it is meant for (e.g. "Alarm devices").

Type: Steady / continuous (default)
Intermittent
Pulse
Steady, delayed activation
Intermittent, delayed activation
Pulse, delayed activation
Steady, delayed de-activation.

Depending on the selected type, one or more of the following fields might have to be filled-in.

Delay time: Can be set to 0-255 x 0.8 = 0 - 204 sec.

Pulse length: Can be set to 0-255 x 0.8 = 0 - 204 sec.

Pulse off: Can be set to 0-255 x 0.8 = 0 - 204 sec.

De-activation: Can be set to 0-255 x 0.8 = 0 - 204 sec.

20.2.5

National holidays

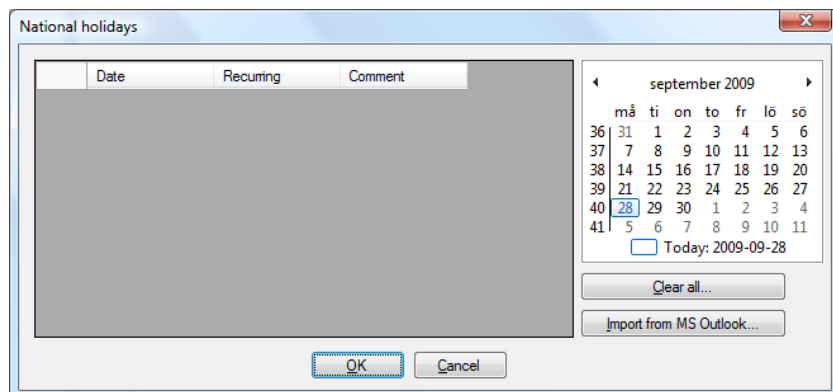

Up to twenty national holidays can be set for the whole system.¹²⁴

National holidays can be added one by one, i.e. by selecting a date in the calendar (up to the right) and click with the left mouse button. A row with that date will be added in the list (to the left). To delete a date in the list, click on the date in the calendar with the left mouse button.

If Microsoft® Outlook® is installed on your PC the national holidays can be automatically added in the list by clicking "**Import holidays from Outlook...**".¹²⁵

Mark the checkbox "**Recurring**" if a holiday recur the same date every year, e.g. Christmas Day, Boxing Day, etc.

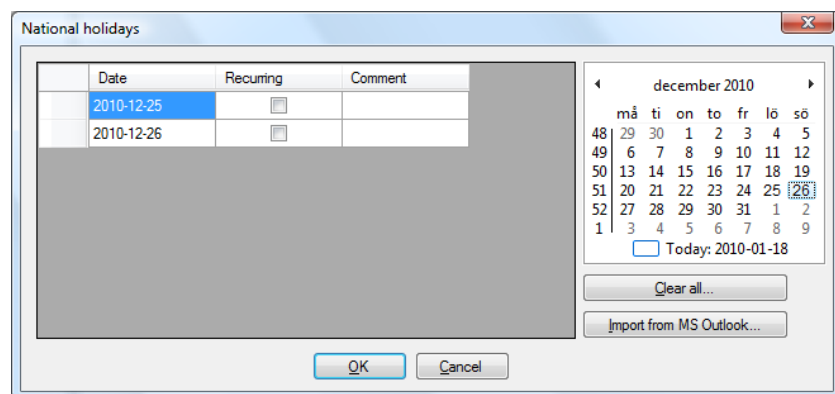
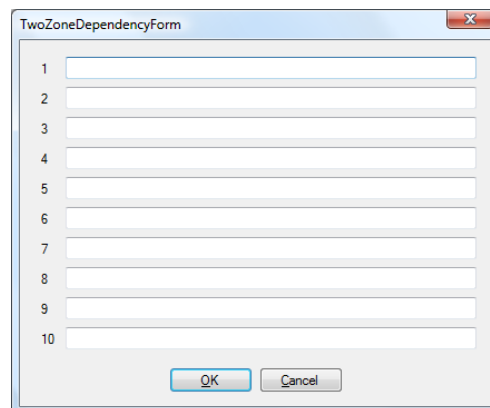

Figure 29. In this example the first row is selected (blue marked).

20.2.6 Two zone dependence



See also chapter "2-zone dependence", page 101.

¹²⁴ **NOTE!** ON/OFF times for each time channel (1-14) and every day of the week (incl. national holidays) have to be set.

¹²⁵ The National holidays have first to be imported to Microsoft® Outlook. The number and dates of national holidays varies between different countries.

Default for all zones is no two zone dependence.

NOTE!

Normally, only conventional zones (i.e. zone line inputs with conventional detectors) should be used for two-zone dependence.

For analog / addressable detectors the two-address (unit) dependence should be used.

Ten (1-10) groups are available.

For each group, write the zone numbers for the two-zone dependent zones (min. two zones!!!) in the white field/line. Use comma as punctuation mark between the zone numbers or a sequence (e.g. xxx-yyy).

NOTE!

Check so that two or more zones are programmed in each group. (A single zone in a group will never be able to activate any fire alarm!)

20.2.7 System information

In this dialog box you can **read** the following information:

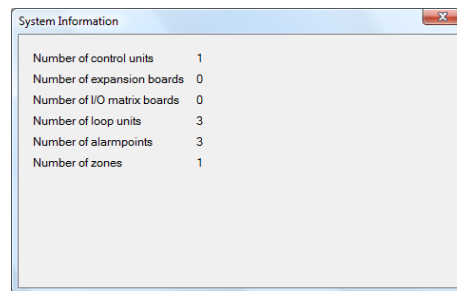

This is what has been programmed so far in the system. The information will be updated when units etc. are added or deleted.

20.2.8 Edit Alarm texts

The user definable alarm text for each alarm point can be created / edited in the alarm point dialog box respectively or via the menu: Systems | Edit Alarm texts. See **Text editor**, page 114.

20.2.9 Alarm points

This is a list showing all alarm points and their properties.

Alarmpoint	Control Unit	Loop	Loop Unit	Input	Expansion board	Text	Delayed	Quiet alarm	Alert announcement time channel	Disable time channel	Dependent time channel
001-01	Control unit 0 - Alfa	Loop 0	001: MCP 3333			Manual Call Point 3333	<input type="checkbox"/>	<input type="checkbox"/>	Always off	Always off	Always off
001-02	Control unit 0 - Alfa	Loop 0	002: AHD 3308, 3309			Analog Heat Detector 3308	<input type="checkbox"/>	<input type="checkbox"/>	Always off	Always off	Always off
002-01	Control unit 0 - Alfa	Loop 0	003: Analog photoelectric smoke detector 4301			Analog photoelectric smoke detector 4301	<input type="checkbox"/>	<input type="checkbox"/>	Always off	Always off	Always off
002-02	Control unit 0 - Alfa	Loop 0	005: AMD Analog Multi Detector (4300)			Analog Multi Detector (smoke) 4300	<input type="checkbox"/>	<input type="checkbox"/>	Always off	Always off	Always off
002-03	Control unit 0 - Alfa	Loop 0	005: AMD Analog Multi Detector (4300)			Analog Multi Detector (heat) 4300	<input type="checkbox"/>	<input type="checkbox"/>	Always off	Always off	Always off
010-01	Control unit 0 - Alfa	Loop 0	007: Analog photoelectric smoke detector 4301			Analog photoelectric smoke detector 4301	<input type="checkbox"/>	<input type="checkbox"/>	Always on	Always off	Always off
010-02	Control unit 0 - Alfa	Loop 0	009: AHD 3308, 3309			Analog heat detector 3309	<input type="checkbox"/>	<input type="checkbox"/>	Always off	External time channel 1	Always off
020-01	Control unit 0 - Alfa	Loop 1	001: 2304			Smoke detector 2304 / base 2312	<input type="checkbox"/>	<input type="checkbox"/>	Always off	Always off	Always off
100-01	Control unit 0 - Alfa	Loop 0	010: I/O 3361	Input 0		3361 zone line input	<input type="checkbox"/>	<input type="checkbox"/>	Always off	Always off	Always off
101-01	Control unit 1 - Bravo	Loop 0	001: MCP 3333			Manual Call Point 3333	<input type="checkbox"/>	<input type="checkbox"/>	Always off	Always off	Always off
101-02	Control unit 1 - Bravo	Loop 0	002: AHD 3308, 3309			Analog Heat Detector 3308	<input type="checkbox"/>	<input type="checkbox"/>	Always off	Always off	Always off
102-01	Control unit 1 - Bravo	Loop 0	003: Analog photoelectric smoke detector 4301			Analog photoelectric smoke detector 4301	<input type="checkbox"/>	<input type="checkbox"/>	Always off	Always off	Always off
102-02	Control unit 1 - Bravo	Loop 0	005: AMD Analog Multi Detector (4300)			Analog Multi Detector (smoke) 4300	<input type="checkbox"/>	<input type="checkbox"/>	Always off	Always off	Always off
102-03	Control unit 1 - Bravo	Loop 0	005: AMD Analog Multi Detector (4300)			Analog Multi Detector (heat) 4300	<input type="checkbox"/>	<input type="checkbox"/>	Always off	Always off	Always off
110-01	Control unit 1 - Bravo	Loop 0	007: Analog photoelectric smoke detector 4301			Analog photoelectric smoke detector 4301	<input type="checkbox"/>	<input type="checkbox"/>	Always off	External time channel 1	Always off
110-02	Control unit 1 - Bravo	Loop 0	010: AHD 3308, 3309			Analog heat detector 3309	<input type="checkbox"/>	<input type="checkbox"/>	Always off	Always off	Always off
200	Control unit 1 - Bravo				DET 4580 B zones expansion board	DET B zone line input	<input type="checkbox"/>	<input type="checkbox"/>	Always off	Always off	Always off
333	Control unit 0 - Alfa				DET 4580 B zones expansion board	DET B zone line input	<input type="checkbox"/>	<input type="checkbox"/>	Always off	Always off	Always off

21 Download SSD

The PC program **WinG3** is used for programming of the site specific data (SSD) and to download it into the EBL512 G3 control unit(s) and/or 1728, 1735, 1736, 1826 & 1828 units.

When the units are running, i.e. the power is turned on and the TLON network is running, the SSD download can take place.

The PC has to be connected to the USB port (type "B") in a control unit. Start WinG3. Log on to the control unit, access code for level 3B shall be entered via the PC (WinG3).

In WinG3 (menu "Tools" | "Download SSD..."), you select the unit(s) to which the SSD shall be downloaded.¹²⁶

21.1 Check Loop

In the WinG3 COM loop icon pop-up menu select "Check Loop". This function can be used after (or before) the download of SSD. The function is as follows:

The control unit will find all units that are connected on the COM loop. If there is a break (cut-off) or short circuit on the loop only the units found in the A-direction will be shown, i.e. an indication where the break (cut-off) or short circuit is located.

For all units the address (1-255) and the type of unit will be reported to WinG3. All differences compared to the WinG3 SSD will be listed in WinG3 and can be saved and/or printed out.

NOTE! During this check the COM loop will be disconnected (disabled) and no alarms or faults can be activated. Disconnected COM loop is indicated by the LED **Fault / Disablements** "General disablements" (L10).

21.2 Single Control Unit

Start the downloading from WinG3. A text message will be shown in the control unit display "Downloading SSD".

When the download is completed the control unit will restart (see chapter "**Error! Reference source not found.**", page **Error! Bookmark not defined.**).

After the restart another text message will be shown in the display:

FAULT: Restart control unit nn, code 03
YYYY-MM-DD HH:MM

¹²⁶ After SSD download the control unit will restart. A number of faults might then be generated, e.g. due to not connected units. This will cause "heavy traffic" on the network, which might affect (delay) the SSD download to the other units.

If the download was not ok another fault will be generated.

FAULT: Site specific data (SSD), CU nn
YYYY-MM-DD HH:MM

This text message means that the SSD have **not** been downloaded properly, i.e. a new download has to be performed.

21.3 Control Units in a TLON network

The SSD for all control units can be downloaded via a PC (WinG3), connected to one control unit. The download will be performed to the control units, one at a time, according to the chapter "Single Control Unit" above. The download is performed in a consecutive order, i.e. 0-1-2-3-4-.....-29 amongst the selected control units **but** the control unit where the PC is connected will automatically be the last one to get the SSD downloaded.

When the SSD download to a control unit is completed, that control unit will automatically restart, see chapter "**Error! Reference source not found.**", page **Error! Bookmark not defined.**

21.4 User definable text messages download

When a fire alarm is activated (e.g. an addressable alarm point), the presentation number (Zone - Address) will be shown in the control unit display (see page **Error! Bookmark not defined.**) as well as in the ext. FBP 1826 / 1828 display¹²⁷. There will also be shown a user definable alarm text, if programmed.

All user definable text messages, up to 40 alphanumeric characters each, are created and downloaded (included in the site specific data – SSD) via **WinG3**. See Planning Instructions, chapter "User definable text messages".

Each alarm point can have a unique text message.

Each zone can have a unique text message.

Each zone line input can have a unique text message.

The user definable text messages will be printed out when a printer is available.

¹²⁷ This is also valid for the Ext. Presentation unit 1728 and the Alert Annunciation units 1735 / 1736.

22 Download software (S/W)

The latest software (S/W) version of the EBL512 G3 system program is factory downloaded before the delivery. Due to continual development and improvement, different S/W versions can be found.

The valid S/W version for the Main board 5010 and the MMI board 5011 respectively, can be read in menu H4/U7 (system information) or via WinG3. On site, new S/W can be downloaded via WinG3.

EBL512 G3 type **5000** has both a Main board 5010 and an MMI board 5011. EBL512 G3 type **5001** has only a Main board 5010.

On site, new S/W for the 1728, 1735, 1736, 1826 & 1828 units can be downloaded via WinG3. See the "Technical Description" for the unit respectively.

22.1 Single control unit (c.i.e.)

A single c.i.e. shall not have a TLON connection board 1590 / **5090** mounted. (When a c.i.e. has a TLON connection board 1590 / **5090** mounted, it is expected to be one c.i.e. in a TLON network and TLON network programming is required.)

To download a new software (system program) version, a PC and **WinG3** are used. The BIN file that shall be downloaded contains software for the main board 5010, software for the MMI board 5011 and a text file, i.e. there is one BIN file for each language / country.

1. Connect the PC to the USB connector in the c.i.e. and start WinG3. In the "Tools" menu select "Download Software..." to open the dialog box and do the required settings:
 - Select the path and the software file name, e.g. *English_EBL512G3_110.BIN* (110 = version 1.1.0.)
 - Mark the checkbox "No MMI board" if it is an EBL512 G3 type **5001**, i.e. the MMI software and the text file will **not** be downloaded.
 - Select the COM port to be used on your PC.

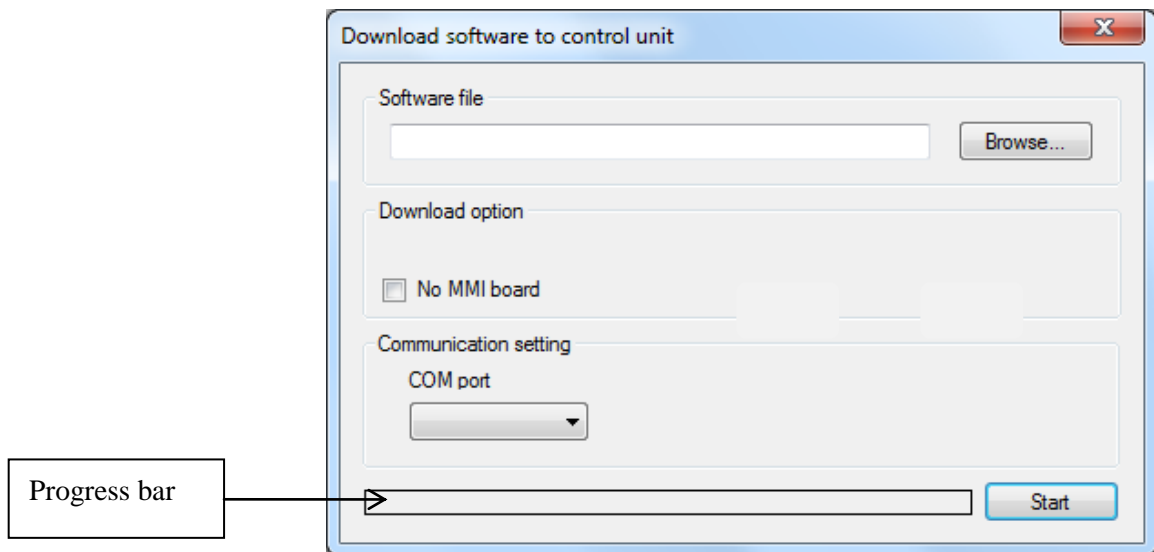

2. Set the Main board 5010 in "boot" mode, i.e. hold the "Boot" button (SW2) down and push the "RESET" button (SW1) momentarily. Release the "BOOT" button. The Main board LED "D24" is turned off while the Main board is in "boot" mode.
3. Start the download, i.e. click "Start".
LED "Operation" (L5) will be turned off.
LED **Fault / Disablements** "General fault" (L9) is turned on, indicating that EBL512 G3 is in the "boot" mode.
LED "System fault" (L7) will be turned on.
If it is an EBL512 G3 type **5000** (i.e. with front), another dialog box opens,

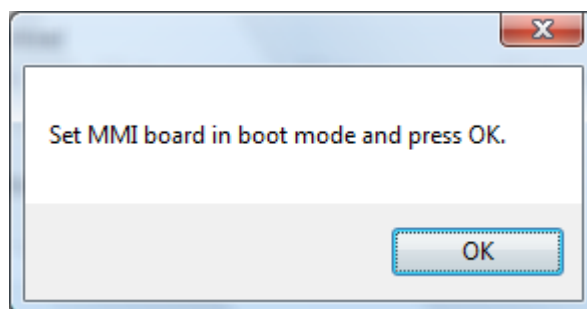

- Set the MMI board 5011 in "boot" mode, i.e. hold the "BOOT" button (SW2) down and push the "RESET" button (SW1) momentarily. Release the "BOOT" button. The MMI board LED "D18" turned off while the MMI board is in "boot" mode.
4. Click "OK".
The download status is indicated by the progress bar.
 5. When the progress bar has gone from "red to green" the download is completed and the following dialog box opens:

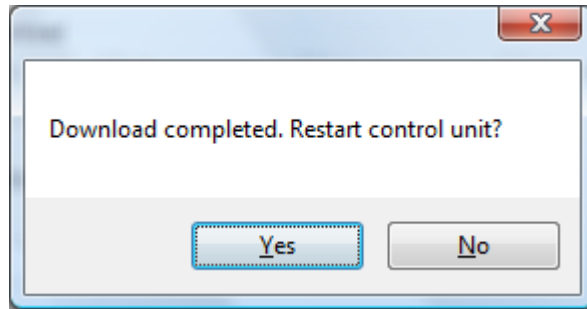

Click "Yes" and the control unit will restart. Regarding the restart, see also chapter "**Error! Reference source not found.**", page **Error! Bookmark not defined.**

6. LED "Operation" (L5) will be turned on and the other LEDs will be turned off.

22.2 Control Units in a TLON network

All control units connected to a TLON network **shall** have the same software version.

For download of new software in each control unit, follow the procedure described above.

Since some control units do not have contact with some control units during the downloading, the following faults might be generated:

FAULT: Control unit xx has no contact with control unit xx,
network x
yyyy-mm-dd hh:mm

FAULT: CU xx has wrong information
yyyy-mm-dd hh:mm

The faults have to be acknowledged.

23 Compatibility

Regarding backwards compatibility:

- Addressable short circuit isolator 4370 is compatible with Addressable short circuit isolator 4313.

NOTE! In system EBL512 G3 shall all Addressable short circuit isolators be set to NORMAL mode.

24 Cable types

A fire alarm installation is a safety installation and it is important that the cables used are of correct types and according to national regulations, e.g. regarding cable colour, method of mounting, etc. Fire alarm cables should, when possible, be installed as far away from other cables as possible, in order to avoid disturbances from these.

The maximum cable length is depending on the cable type (area, twisted / not twisted pairs, screen / no screen), the units' current consumption, etc.

24.1 TLON Network cables

A shielded Belden cable with twisted pair should be used, e.g. JY (St) Y 2 x 2 x 0.8 or 7703 NH 1 pair 22 AWG.¹²⁸

See also separate TLON Technical description.

24.2 COM loop cables

Loop topology is used for highest safety, i.e. the cable, connected in the control unit, returns back to the control unit. In case of a break on the loop, communication in two directions starts.

See dwg. 512 G3 – 25, – 31 and – 41.

Cable length is depending on the type and number of loop units, etc. See chapter "COM loop cable length", page 154 and dwg. 512 G3 - 41.

ELQYB 2 x 1 mm (0.75 mm²) or equivalent (twisted pair).

ELQYB 10 x 2 x 1 mm or equivalent, when feeder line is required.

If screened cable is used, the screen shall be connected close to each loop unit and only incoming (or outgoing) screen to the c.i.e. earth point.

24.3 Ext. FBP / Display Units cables

RS485. Max. cable length \leq 1200 m to the furthest away D.U.

Cable type LIHCH-TP 2 x 2 x 0.75 mm² or equivalent (twisted pair).

24.4 Conventional zone line cables

Inputs to 8 zones expansion board 4580 and Multipurpose I/O unit 3361. See dwg. 512 G3 - 33 and - 36.

ELQRB 2 x 0.6 mm (0.3 mm²) or equivalent. Max. 50 ohm cable resistance (= 400 m cable length).

¹²⁸ For longest possible cable length Echelon recommends an unshielded cable type but the EBL512 G3 VdS approval require shielded cable.

24.5 Alarm device cables

Alarm devices (sounders, etc.), see dwg. 512 G3 – 23, – 35 and – 38.

ELQRB 2 x 0.6 mm (0.3 mm²) or equivalent.

ELQRB 10 x 2 x 1 mm (0.75 mm²) or equivalent, when feeder line is required.

24.6 Other cables

External indicator (LED), door release magnets, etc. E.g:

ELQRB 2 x 0.6 mm (0.3 mm²) or equivalent.

25 COM loop cable length

The cable length and max. COM loop current, are depending on the number and type of loop units and the cable type, see Figure 30 and Figure 31, page 155 and 156 respectively.

One of the graphs in each figure has to be used depending on which type of units that are connected to the COM loop. Start checking the terms below for Graph 1 and Graph 2.

1. Graph with circular dots.

Has to be used when at least one 3361 unit with the monitored input 0 used as a zone line input (Z) is used with conventional detectors (e.g. 4350 / 4352) and end-of-line capacitor.

NOTE! No "old" conventional smoke detectors of type 231x/2321 (i.e. requiring ≥ 15 V) must be used.

2. Graph with no dots

Shall normally be used, i.e. if the graph 1 (see above) not has to be used.

The following two figures are showing graphs for maximum conductor (wire) resistance and maximum cable length respectively.

Excel sheet

An Excel sheet is available for an easy check of the current consumption, cable length, etc.

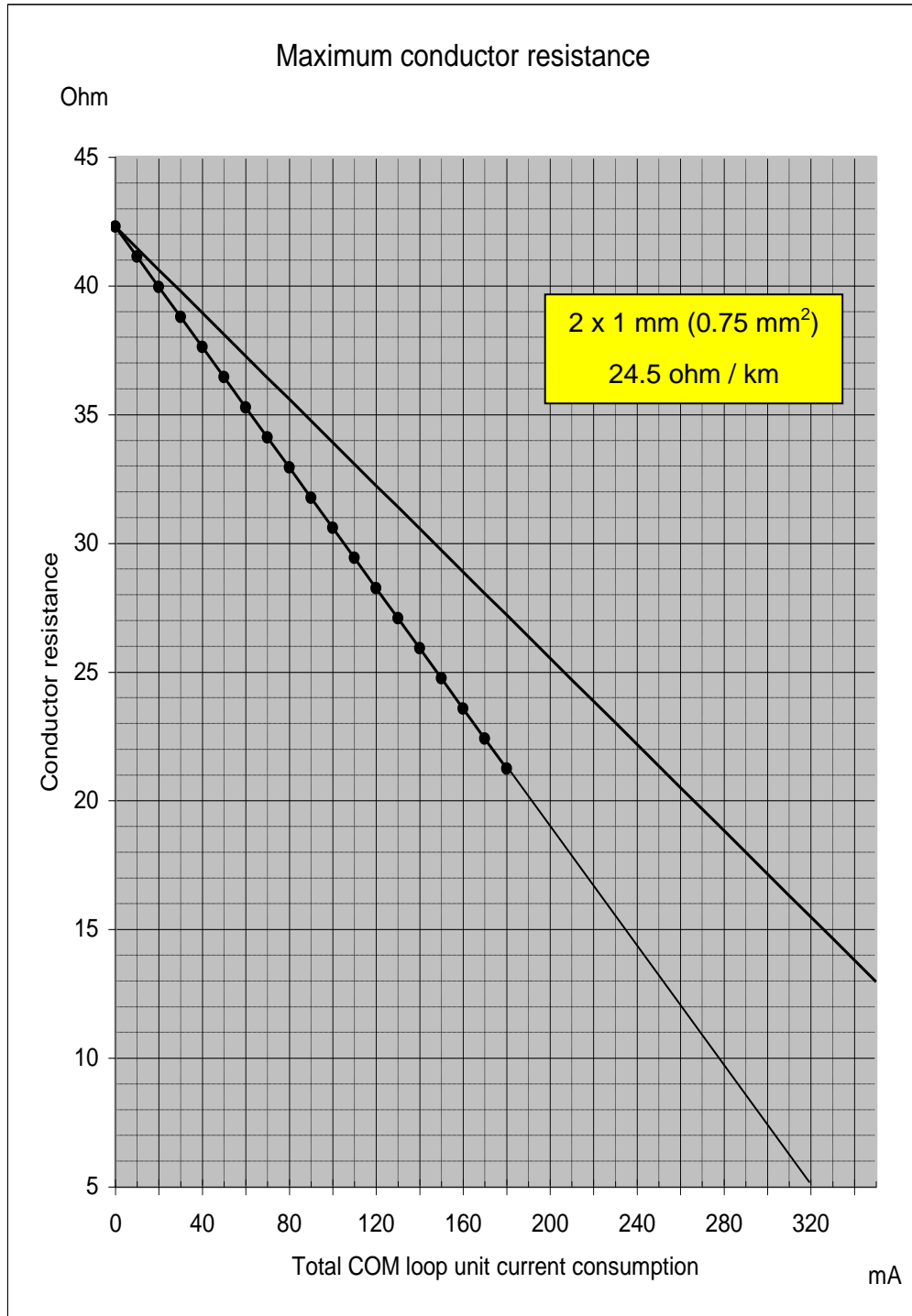

Figure 30. Graphs showing the total conductor resistance in relation to the COM loop units' total current consumption. **NOTE!** The graphs start at "0 mA" but graph 1 ends at "320 mA" and graph 2 ends at "350 mA". End of graph = max. allowed loop current. (42.3 ohm = 863 m cable length.)

NOTE! The graphs are valid for the cable type ELQYB 2 x 1 mm (0.75mm²) with the conductor resistance 24.5 ohm / km. The total conductor resistance (ohm) = L conductor (ohm) + C conductor (ohm).

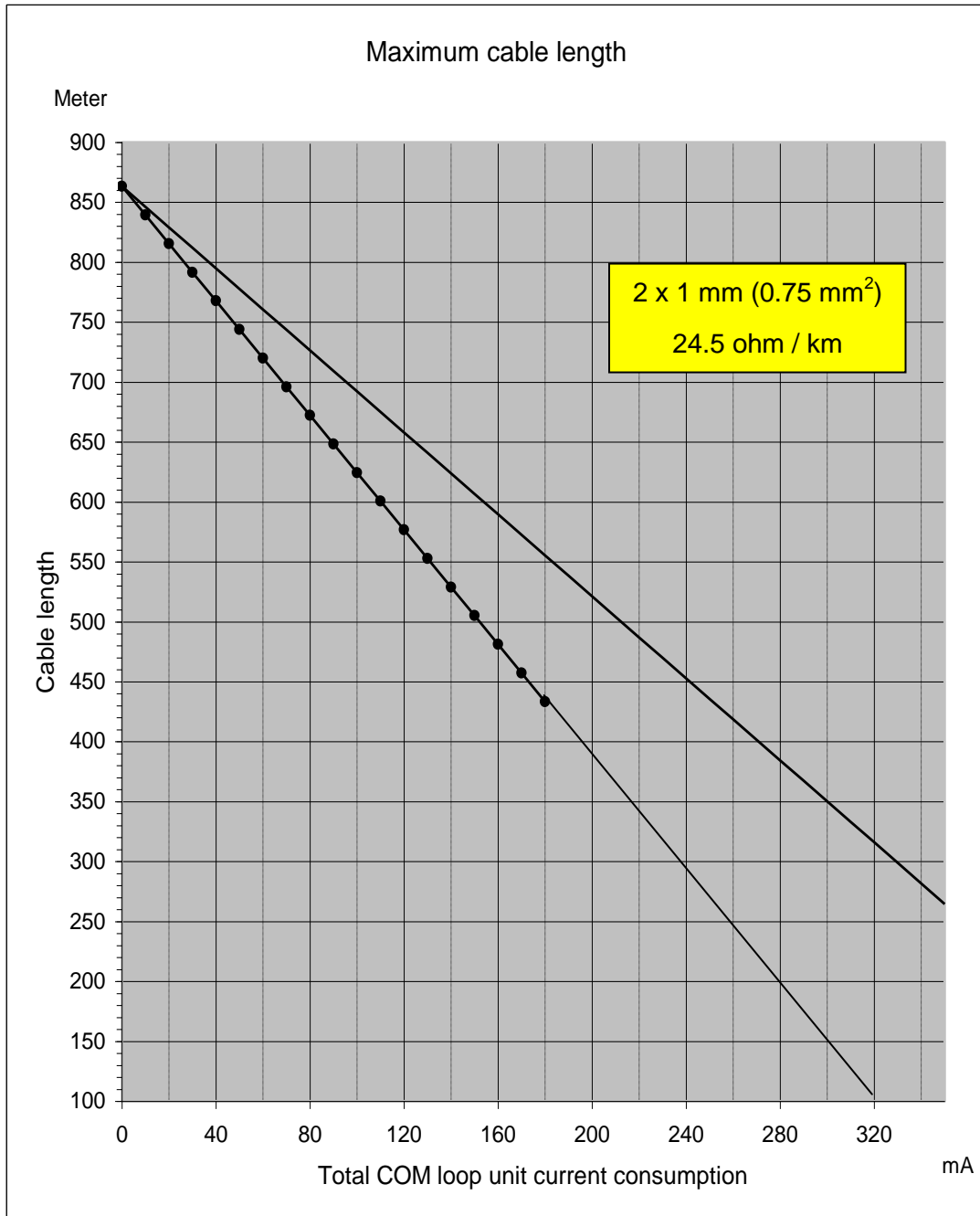

Figure 31. Graphs showing the cable length in relation to the COM loop units' total current consumption. **NOTE!** The graphs start at "0 mA" and 863 m cable length respectively but graph 1 ends at "320 mA" and graph 2 ends at "350 mA". End of graph = max. allowed loop current. (863 m cable length = 42.3 ohm.)

NOTE! The graphs are valid for the cable type ELQYB 2 x 1 mm (0.75mm²) with the conductor resistance 24.5 ohm / km. The total conductor resistance (ohm) = L conductor (ohm) + C conductor (ohm).

26 Current consumption

The different loop units have different current consumption. Note that some units have much higher current consumption in "active state". To check the current consumption on the COM loops, cable lengths, etc. the tables below can be used. See also dwg. 512-41 and chapter "COM loop cable length", page 154. Also, to get a total current consumption overview and to check if the battery capacity is enough, the tables below can be used.

The current consumption is normally shown at nominal voltage (24 V DC), in **Normal state** (quiescent) and in **Alarm state** (active). By battery back-up (i.e. no mains) the voltage can be 27 – 21 V DC.

See also chapter "Power supply", page 161.

C.i.e. units		Normal state (quiescent) (mA)	Alarm state (active) (mA)
Control unit 5000 (without printer)	¹²⁹	230	290
Control unit 5000 (with printer)	¹²⁹	253	312 ¹³⁰
Control unit 5001 ("grey box without front, printer, etc.)	¹²⁹	179	214
Printer in 5000		23	350
8 zones expansion board 4580		15 ¹³¹	15 ¹³²
8 relays expansion board 4581		15	15
In & outputs expansion board 4583, no units connected		15	15
TLON connection board 1590 / 5090		approx. 5	approx. 5
Web-server II 1598		60	65

The control unit values above are measured during battery back-up (i.e. no mains).

¹²⁹ Control unit – backup battery powered. COM loops and ext. equipment current consumption not included.

¹³⁰ When the printer is active the current consumption is 667 mA momentarily.

¹³¹ Add 0.5 mA per input (zone) for end-of-line capacitor (470 nF) and 3 mA per input for end-of-line resistor (10K).

¹³² Add 30 mA per input (zone) activated. (Each input has a 30 mA current limitation, i.e. also for short-circuit on the line.)

COM loop units (input / display units)		Normal state (quiescent) (mA)	Alarm state (activated) (mA)
Analog heat detector 3308 + analog base 3312xx	¹³³	0.3	2.3
Analog heat detector, enclosed 3309	¹³³	0.2	1.7
Analog multi detector 4300 + analog base 3312xx	¹³³	0.3	2.3
Analog smoke detector 4301 + analog base 3312xx	¹³³	0.3	2.3
Addressable manual call point 3333 / 3339		2	5
Alarm Acknowledge Facility Control (AAFC)	¹³⁴	2	5
Addressable base station for wireless units 4610	¹³⁵	5	5

NOTE! On each COM loop, up to 5 sensors / detectors can have their LEDs lit at the same time.

COM loop units (output units, etc.)		Normal state (quiescent) (mA)	Alarm state (activated) (mA)
Analog base with isolator 4313	¹³⁶	≤ 1.3	≤ 1.3
Addressable multipurpose I/O unit 3361		2.2	max. 12 ¹³⁷
Addressable 2 voltage outputs unit 3364	¹³⁸	≤ 6	≤ 6
(Addressable) External power supply 3366		≤ 15	≤ 15
Addressable siren 3377		1	max. 13
Addressable sounder base 3379		0.75	max 3
Addressable beacon 4380		1.7	4-5
I/O matrix board 4582		max. 6	max. 6
Fan control application board 4594	¹³⁹	4-6	4-6

Other units	Normal state (quiescent) (mA)	Alarm state (activated) (mA)

¹³³ Extern LED current consumption. 2218: add 1 mA.

Analog base with isolator 4313 can be used instead of Analog base 3312.

¹³⁴ This unit is available on the Australian market only.

¹³⁵ 24 V DC power supply also required.

¹³⁶ Detector not included.

¹³⁷ Only if the input In 0 is used as a zone line input, else approx. 2.2 mA.

¹³⁸ External 24 V DC power supply also required, e.g. the 3366 unit.

¹³⁹ Two 4594 boards are mounted on a Fan control panel 4594. 24 V DC power supply also required.

Routing equipment (Fire brigade tx / Fault tx)	Acc. to the producer	Acc. to the producer
External Presentation unit 1728	26@24 V / 48@12 V	49@24 V / 88@12 V
Alert Annunciation unit 1735 / 1736	26@24 V / 48@12 V	42@24 V / 79@12 V
External FBP 1826 / 1828	26@24 V / 48@12 V	49@24 V / 88@12 V
Printer 1835 (for ext. FBP 1826) ¹⁴⁰	4@24 V / 7@12 V	4@24 V / 7@12 V
Alarm devices (sounders, etc.)	0	Acc. to the producer
Door release magnets	Acc. to the producer	0
Alert annunciation controller 1740	10	40

NOTE! Regarding the 1728, 1735, 1736, 1826, 1828 and 1835 units, see the next page.

¹⁴⁰ When the printer is active the current consumption is 161 / 345 mA momentarily.

The following table is a **help** when calculating the cable length and/or the number of units. The table is based on the current consumption at the lowest power supply voltage allowed i.e. 21 V DC by battery back-up (no mains).

Recommended cable type is LIHCH-TP 2 x 2 x 0.75 mm².
Wire resistance for this cable is approx. 25 ohm / 1000 m.

Up to sixteen units can be connected but it is depending on the type of units and the cable (type and length).

Number of units	Allowed cable resistance (ohm) / length (m)		
	Units 1735, 1736	Units 1728, 1735, 1736, 1826 ¹⁴¹ , 1828 ¹⁴¹ & <u>no printers</u> 1835	Units 1728, 1735, 1736, 1826, 1828 & <u>one</u> ¹⁴² printer 1835
8	12 / 240	11 / 220	-
7	14 / 280	13 / 260	-
6	17 / 340	15 / 300	-
5	20 / 400	18 / 360	-
4	25 / 500	21 / 420	4 / 80
3	34 / 680	28 / 560	10 / 200
2	50 / 1000	42 / 840	16 / 320
1	100 / max. 1200	84 / max. 1200	18 / 360

Explanation: 12 (ohm) ÷ 25 (ohm wire resistance per 1000 m) = 480 m but the wire goes from the c.i.e. to the last unit and back to the c.i.e. again, i.e. the cable length = 480 (m) ÷ 2 = 240 m.

NOTE!

The table is based on the recommended cable type. If a cable with greater area is used the wire resistance (ohm per 1000 m) will be lower and the possible cable length will be longer.

It is also possible to use an external power supply, e.g. 3366, when a greater number of units are required or if a longer cable length is required.

¹⁴¹ Max. six 1826 / 1828 units.

¹⁴² Printing will only be performed if and when the door in the ext. FBP is being opened. If the door is not opened until after all the alarms are reset, there will be no printing.

27 Power supply

Main power source

Normally the EBL512 G3 control unit is powered by the built-in rectifier (230 V AC / 24 V DC $\pm 1\%$, 6.5 A).

Second power source

By loss of 230 V AC etc. the control unit is powered by a backup battery¹⁴³, i.e. two Sealed Lead-Acid batteries, 12 V, 17 – 65 Ah (see tables on page 165 and forward).

There is space in the EBL512 G3 control unit for two Sealed Lead-Acid batteries, 12 V, 28 Ah, physical size 175 x 165 x 125 mm.

Recommended type is Panasonic LC-X1228AP.

Larger batteries have to be placed outside the control unit.

The batteries and the rectifier are connected to the Main board 5010 (see dwg. 512 G3 – 21), which also handles the charging of the batteries.

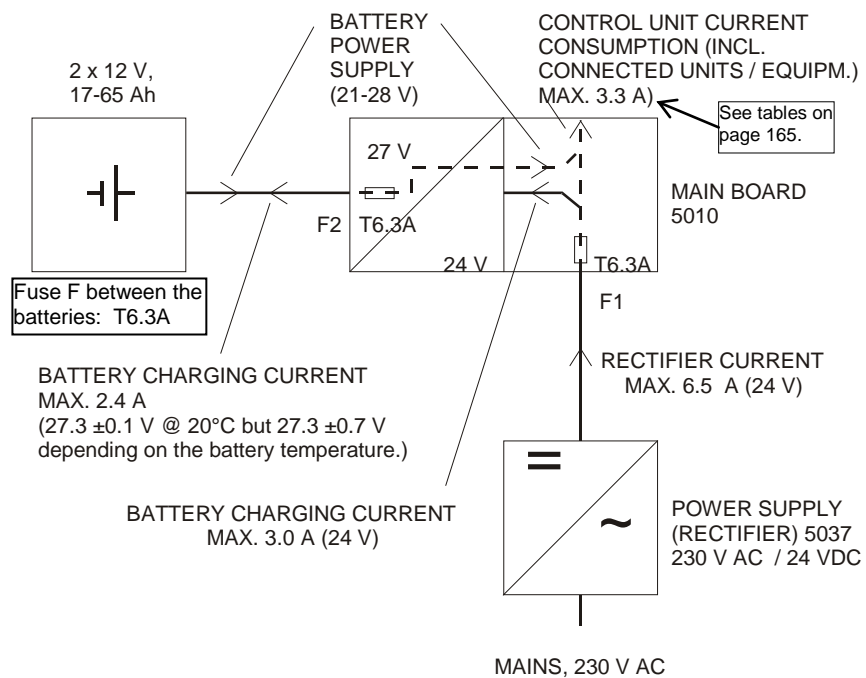

Figure 32. EBL512 G3 power supply block diagram.
Fuses F, F1 & F2: T6.3A H 250 V (5x20 mm Ceramic).
Batteries inside the c.i.e.: Max. 28 Ah.

EBL512 G3 is a very flexible system, i.e. number of and types of loop units, number of and types of expansion boards, ext. FBPs, ext. equipment, etc. can vary from one control unit to another.

¹⁴³ **NOTE!** The batteries (2 x 12 V) are not included in the Control unit type no. 5000 & 5001. Batteries with the same physical size but with different capacities are available on the market (e.g. 24 / 28 Ah).

27.1 Charger functions

According to EN54-4, section 5.3.1 b): *The charger shall be designed and rated so that a battery discharged to its final voltage can be recharged to at least 80% of its rated capacity within 24 hours and to its rated capacity within another 48 hours.*

27.1.1 Charging

If the EN54-4 section is to be fulfilled, the battery capacity of the backup batteries is limited to 65 Ah.

However, batteries of larger capacity are possible to use but will not be recharged within the prescribed time interval, i.e. an EN54 violation.

Batteries of smaller capacity, i.e. $< 17 \text{ Ah}^{144}$, are not recommended since the charging current in step 1 (see below) is 2.4 A, which normally is higher than the recommended maximum charging current for these batteries. Too high charging current can cause abnormal internal heating which may damage the batteries.

27.1.2 Battery charging functions:

Battery charging is performed in two steps:

1. **Constant current.** The charging current is constant (fixed) until the battery / charging voltage reaches 29 V.
2. **Constant voltage.** The charging voltage is reduced from 29 to something between 26.6 and 28.2 V (depending on the temperature) and will be constant (fixed) at this level until the batteries are fully charged.

When the battery is fully charged the stand-by "charging current" is 0-0.5 A (typical 0.1 A) and the "charging voltage" will stay constant (fixed) at the "step 2" level, until the batteries have been discharged and have to be charged again. A new charging cycle will then start. The duration of "step 1" and "step 2" respectively is depending on the battery shape when the charging starts.

27.1.3 Security functions

- The battery charging will be turned off if the current from the Rectifier 5037 to the Main board 5010 exceeds 6.3 A. The battery charging will remain turned off as long as the EBL512 G3 current consumption exceeds 3.3 A. The following fault message will be shown:

FAULT: Control unit xx high current consumption

¹⁴⁴ The Panasonic 17 Ah battery of type **LC-RD1217AP** can be used.

- In case of charger out of work the following fault message will be shown:
FAULT: Charger control unit xx
- In order to not damage the batteries, the voltage output will be switched off at approx. 20.8 V. This only happens in case of no main power source (230 V AC), i.e. when the backup batteries are used as power source.
- If the battery voltage is below 10 V (5 V per battery), the battery charging will be turned off. (The batteries are damaged and have to be changed.)
- In case of no mains and after a time delay of 1-300 minutes (programmable in WinG3 but max. 30 min. according to the EN54-2 standard), the following fault message will be shown:

FAULT: Mains, control unit xx

27.2

Current consumption calculations

For each control unit, in order to get a current consumption overview so that the rectifier will not be overloaded and to check / calculate the required battery capacity, the total EBL512 G3 current consumption (excl. battery charging current) have to be calculated. **NOTE!** There is no battery charging during fire alarm.

Use the values in chapter "Current consumption", page 157, to calculate the following current consumptions:

- I^{CN} = current consumption for the control unit¹⁴⁵ in normal state.
- I^{RN} = current consumption for all other equipment¹⁴⁶ in normal state.
- I^{CA} = current consumption for the control unit¹⁴⁵ in alarm state.
- I^{RA} = current consumption for all other equipment¹⁴⁷ in alarm state.

The total EBL512 G3 current consumption in **Normal** (quiescent) state: $I^{TN} = I^{CN} + I^{RN}$

The total EBL512 G3 current consumption in **Alarm** (activated) state: $I^{TA} = I^{CA} + I^{RA}$

Comments regarding (I^{TN}):

I^{TN} shall be ≤ 0.93 A if the built-in battery is a 28 Ah battery, because this results (theoretically) in 30 hours battery backup time.

¹⁴⁵ Including the COM loop units but excl. the battery charging current.

¹⁴⁶ External equipment connected to the control unit (e.g. ext. FBPs, door release magnets, relays, routing equipment, etc.).

¹⁴⁷ External equipment connected to the control unit (e.g. ext. FBPs, sounders, relays, routing equipment, etc.).

I^{TN} is max. 3.3 A but if the required battery backup time is 30 hours
 I^{TN} can be max. **0.93 A**.

Comments regarding (I^{TA}):

I^{TA} has to be \leq **6.3 A**. (The battery charging will be turned off in conjunction with fire alarm activated in the system.)

For the total EBL512 G3 current consumption in relation to **backup time**, see tables in chapter "Battery (second power source)", page 164.

27.3 Rectifier (main power source)

The rectifier (5037) technical data is 230 V AC / 24 V DC, 6.5 A but the main board fuse F1 = 6.3 A, i.e. **the total current consumption incl. max. battery charging current must not at any time exceed 6.3 A**. Allowed input voltage is 176-264 V AC. The output voltage is 24 V with a tolerance of $\pm 1\%$.¹⁴⁸

27.4 Battery (second power source)

Only batteries with a specified "Final voltage" of 10.5 V must be used. Find out the required battery backup time, according to national regulations / customer demands, in normal state and in alarm state.

Calculate the battery capacity required in normal state (Q^N) and the battery capacity required in alarm state (Q^A) respectively.

- Q^N (Ah) = I^{TN} (A) x battery backup time in normal state (h)
- Q^A (Ah) = I^{TA} (A) x battery backup time in alarm state (h)

The total battery capacity $Q = Q^N + Q^A$ (Ah)

The electrical capacity of the batteries varies with ambient temperature and discharge current. Furthermore the battery voltage at the end of a discharging period is not the same as at the start. For this reason it is wise to round up the calculated capacity and add 10%, as safety margin. Note! If the ambient temperature is below 20 °C the safety margin has to be even larger since the electrical capacity of the batteries decreases. At 0 °C add 30% and at 10 °C add 20% to the calculated capacity.

The following tables show the relation between the total current consumption in normal state (I^{TN}) and the backup time.

NOTE! The values are calculated and will only give you a rough idea of the backup time.

A battery \leq (24) 28 Ah¹⁴⁹ can be placed inside the control unit.

A battery $>$ (24) 28 Ah has to be placed outside the control unit.

¹⁴⁸ The output voltage is factory set to 24 V. On the rectifier is a potentiometer for output voltage adjustment ($\pm 10\%$) available. **Do not use this potentiometer** unless the output voltage is not 24 V.

¹⁴⁹ The battery's physical size is 175 x 165 x 125 mm.

NOTE! For external batteries the following is valid: Max. 3 m cable length (min. 4 mm²). National regulations have to be followed, e.g. regarding external fuses etc. Also, the voltage drop has to be as low as possible, not to affect the battery checking function.

The relation between the total current consumption in normal state (I^{TN}) and the backup time.

One table for the built-in 28 Ah batteries and one table for the external 65 Ah batteries:

NOTE! Theoretical values.

Built-in **28 Ah** batteries:

I^{TN} (A)	Backup time (hours)
3.3	8½
3.1	9
2.55	11
2	14
1.55	18
1	28
0.93	30
0.8	35
0.6	46
0.4	70

External **65 Ah** batteries.

I^{TN} (A)	Backup time (hours)
3.3	19½
3.25	20
2.7	24
2.2	30
1.6	40
1.0	65
0.9	72
0.65	100
0.4	162

27.5 Fuses

There are power supply fuses on the Main board 5010 as follows:

F1 = T6.3A Ceramic. +24 V DC from the rectifier (5037).

F2 = T6.3 A Ceramic. + to/from batteries

Between the batteries:

F = T6.3 A Ceramic.

27.6 Form / Table of current consumption

Some national regulations require different forms / tables regarding current consumption, to be filled-in. In such a case an ampere meter shall be used to read a true value instead of a calculated current consumption.

A tip: Turn off the main power source (230 V AC) and use e.g. a "clamp current meter" on one of the wires between one of the batteries and the Main board 5010, to read the true total control unit current consumption.

An approx. value is displayed via menu H5/A5.

28 S/W versions

Due to continual development and improvement, different S/W versions can be found.

Different S/W versions can be found on different markets.

The S/W versions listed below were the valid ones when this document was written (the date of this document or date of revision).

S/W for:	Latest version	Required version
5000 / 5001; EBL512 G3	1.1.1	1.1.0
4580; 8 zones expansion board, P.c.b. no. 9287-2B	1.0.5	1.0.2
4580; 8 zones expansion board, P.c.b. no. 9287-3A	2.0.4	2.0.4
4581; 8 relays expansion board	1.0.2	1.0
4582; I/O Matrix board	1.0.4	1.0.2
4583; Inputs and Outputs expansion board	1.0.2	1.0
1590; TLON connection board	1.2	1.1
5090; TLON connection board	1.0.0	1.0.0
1728; Ext. Presentation unit (EPU)	1.4.1	1.4.1
1735 / 1736; Alert Annunciation unit (AAU)	1.4.1	1.4.1
1826 / 1828; Ext. Fire Brigade Panel (FBP)	1.4.1	1.4.1
WinG3	1.1.2	1.1.0
TLON Manager	2.0.0	1.2
1598 Web-server II ¹⁵⁰	1.1.1	1.1.0

¹⁵⁰ The Web server is used in other systems as well. The web-server S/W will be downloaded via a PC program called "WebG3 Config tool V X.X.x". **NOTE!** The Config Tool version and the EBL512 G3 S/W version has to be the same (i.e. the first two digits; X.X.x -- X.X.x).

29 Technical data

Voltage

Primary (V AC): **230** (176-264) -- 1.6 A

System (V DC): **24**¹⁵¹

Current consumption (A)

Quiescent / active: Depending on type (5000 or 5001), type and number of exp. boards, connected external equipment, etc.

See chapter "Current consumption", page 157

Ambient temperature (°C)

Operating: 0 to +40

Storage: -40 to +70

Ambient humidity (%RH)

max. 90, non condensing

Ingress protection rating

IP 30

Size H x W x D (mm)

5000: 628 x 438 x 187. See also drawing 512 G3 - 01

5001: 625 x 418 x 177.

Weight (kg)

5000: 20

5001: 19

Colour

5000: Metal cabinet: Aluminium & light grey (NCS S 1500-N / PMS Cool Gray 2)

5001: Metal cabinet: light grey (NCS S 1500-N / PMS Cool Gray 2)

Approvals

Conforms to EN 54-2 and EN 54-4.

The Swedish front conforms to SS3654.

¹⁵¹ The rated output voltage is 24 V DC \pm 1% for the main power source (rectifier). Max. ripple 240 mVp-p. The rated output voltage for the second power source (backup battery) is 20-27 V DC.

30 Limitations

See also "Control Unit / TLON Network", page 18.

30.1 User definable texts

All alarm points etc. can have its own "alarm text" in EBL512 G3.

At least 617 "User definable texts" can be programmed per 1728, 1735, 1736, 1826 and 1828 unit.¹⁵²

30.2 C.i.e. / System

Max. number of "items" for the system is the same as per C.i.e. if nothing else is specified:

.....table on following page...

¹⁵² The texts have to be with "English characters" but for some languages might some already defined language dependent characters be used.

Item	C.i.e.	System
General fire alarm via progr. input	250	
External fault via progr. input		50
Programmable outputs (= control expressions) ¹⁵³	512	
Addressable 2 voltage outputs unit 3364	40	
Interlocking Combinations	200	1000 ¹⁵⁴
Presentation numbers / alarm points ¹⁵⁵ that can be presented in the display(s) in case of fire alarm	512	512
Presentation numbers ¹⁵⁵ that can be programmed	512	30 x 512 = 15 360
Zones ¹⁵⁶ that can be programmed	512	512 ¹⁵⁷
Faults		300
Disabled zones		512
Disabled alarm points (zone/address) + Disabled COM loops		200 ¹⁵⁸
Disabled outputs		200 ¹⁵⁹
Disabled interlocking outputs		200 ¹⁶⁰
Sensors activating SERVICE signal		100
Max. number of AAF zones (Max. 5 detectors per AAF zone.) ¹⁶¹	100	

¹⁵³ Approx. 4000 trigger conditions can be used in these control expressions.

¹⁵⁴ Max. 100 user definable texts can be displayed "at the same time".

¹⁵⁵ Presentation number is a ZONE only or ZONE – ADDRESS.

¹⁵⁶ Any zone number between 001 and 999 can be used for the 512 zones.

¹⁵⁷ Theoretically 999 zones can be programmed but according to EN54-2 it shall be possible to present all "fire alarms" in the display, i.e. max. 512.

¹⁵⁸ Zone/address disabled via time channel not included.

¹⁵⁹ Control outputs disabled via menu H2/B7 and Alarm devices disabled via menu H2/B8 not included.

¹⁶⁰ Interlocking outputs disabled via menu H2/B7 not included.

¹⁶¹ Used in conjunction with the AAF Control, which is available on the Australian market only.

31 National regulations

When planning a fire alarm installation, national regulations, customer demands, etc. have to be followed.

EBL512 G3 is very flexible. Many functions / facilities are built-in the system, e.g. in the S/W and WinG3.

When downloading S/W and SSD, different settings, conventions, languages, etc. can be set to fulfil national regulations.

32 Drawings / connection diagrams

Resulting from continual development and improvement, all dimensions quoted are approximate only and subject to change without notice, as are other technical features and data.

33 Revision history

The changes in conjunction with the latest revision are, when possible, written with **red font colour** in the document.

Revision 1

Small corrections, e.g. spelling errors.

Revisions in the following chapters / paragraphs:

8.3	Info. deleted.
9.1	New pictures.
11.1	Info. added (comment "0")
16.15	Info. added.
17.1	Info. added.

Revision 2

Company name, etc. changed.

TLON Connection board **1590** generally replaced by **1590 / 5090**.

Revisions in the following chapters / paragraphs:

2.1	New company name
2.18	Info. added.
5.2	Info revised.
8 - - 8.3	Info. added.
9.1.3	Info. added. (3377 & 3379)
9.1.6	4596 deleted.
9.2.1	Info. revised. (1826)
11.1	Info. revised. (comment 12). Info. added. (comments 14 & 25)
12.9	Info. revised.
13.5.1	"43" added. Comment 26;Info added. Comment 36;Info added. Comment 43;Added.
15	Info. added. (footnote 86)
16	Info. revised.
16.11	New / added. (Old 16.11 --- 31 renumbered)
16.13	Info added.
16.32	Info. added.
19.2.1	Info. added.
19.2.3	Info. added.
20.1.1	Info. added.
21	New / added. (Old 21, 22, ---- renumbered)
22	New / added.
26	Info. revised. (D.U. table.)

This page has deliberately been left blank.

Panasonic ideas for life

Panasonic Eco Solutions Nordic AB
Jungmansgatan 12, SE-211 19 Malmö, Sweden
Tel: +46 (0)40 697 70 00 • Fax: +46 (0)40 697 70 99
E-mail: info.pewnf@eu.panasonic.com • Internet: pesn.panasonic.se

